

1-1/2" Metallic Models EXpert Series Pumps

1-1/2" Metallic Performance Specifications

Ratio:	1:1
Maximum GPM (LPM):	123 (465)
Displacement per cycle Gallons (Liters):	0.617 (2.34)
Air Inlet (Female):	1/2 - 14 NPT
Fluid Inlet:	1-1/2" - 11-1/2 N.P.T.F.-1, 1-1/2-11 BSP 1-1/2" ANSI/DIN flange
Fluid Outlet:	1-1/2" - 11-1/2 N.P.T.F.-1, 1-1/2-11 BSP 1-1/2" ANSI/DIN flange
Max. operating pressure psi (bar):	120 (8.3)
Suspended solids max. dia. in.(mm):	1/4" (6.4)
Weight lbs (kg):	PX15R-XAX-XXX 37.7 (17.1) PX15R-XCX-XXX 73.2 (33.2) PX15R-XSX-XXX 61.2 (27.8) PX15R-XHX-XXX 86.9 (39.4) <small>Note: add 3.08 lbs (1.4 kg) for Aluminum air motor section add 14.39 lbs (6.53 kg) for Stainless Steel air motor section</small>
Maximum dry suction lift ft(m):	14 (4.2) Elastomer fitted

Sound Level:

PSI	Cycles / Min	db(A)
70	50	81.0



Ordering Menu

PX15	X	-	X	X	X	-	X	X	X
Model Series	Center Section		Connection	Wetted Parts	Hardware		Seat Material	Diaphragm Material	Ball Material
PD15 Standard Pump	A Aluminum		A NPTF Thread	B Aluminum	P Plated Steel		A Santoprene®	A Santoprene®	A Santoprene®
PE15 Electronic Interface Accessible Pump	R Polypropylene S Stainless Steel		B BSP Thread Y 1-1/2" ANSI/DIN Flange (Center) SS Only	C Cast Iron	S Stainless Steel		C Hytrel® E Carbon Steel F Aluminum G Nitrile H 440 Stainless Steel (Hard) L Hastelloy S 316 Stainless Steel	C Hytrel® G Nitrile M Medical grade Santoprene® T PTFE/Santoprene® V Viton®	C Hytrel® G Nitrile S 316 Stainless Steel T PTFE V Viton®

Accessories*

Air Line Connection Kit | Kit No. 66084-1

Kit includes Piggyback Filter/Regulator with gauge, pipe nipple and a 5-foot section of air hose.

Diaphragm Failure Detection (DFD) | No. 67237

Costly production downtime due to pump diaphragm failure and resulting (possibly hazardous) material leakage is a very real problem in many process operations. ARO Diaphragm Failure Detection is one simple, cost-effective way to get your pumps wired for preventive maintenance. (PE15X pump model is required)

Cycle Counter Kit | Kit No. 67350

Like the odometer on your car, ARO's cycle sensing / cycle counter lets you know how many pump cycles have elapsed so you can be prepared to perform preventive maintenance. The cycle sensor is a cost-efficient way to save maintenance costs while keeping your pump on-line. (PE15X pump model is required)

Service Repair Kits | Kit No. 637389 (air motor for PX15X)
Kit No. 637390-X (major air valve assembly)
Kit No. 637375-XX (fluid section)

Screened Inlet Adapter Kit | Kit No. 67174-15

Carbon steel, E-coated screen prevents unwanted solids from entering pump. Kit includes hardware for attachment to pump.

*Please note pumps are not included with these kits.



67174-15 Screened Inlet

1-1/2" Metallic Dimensions and Flow Curves EXpert Series Pump

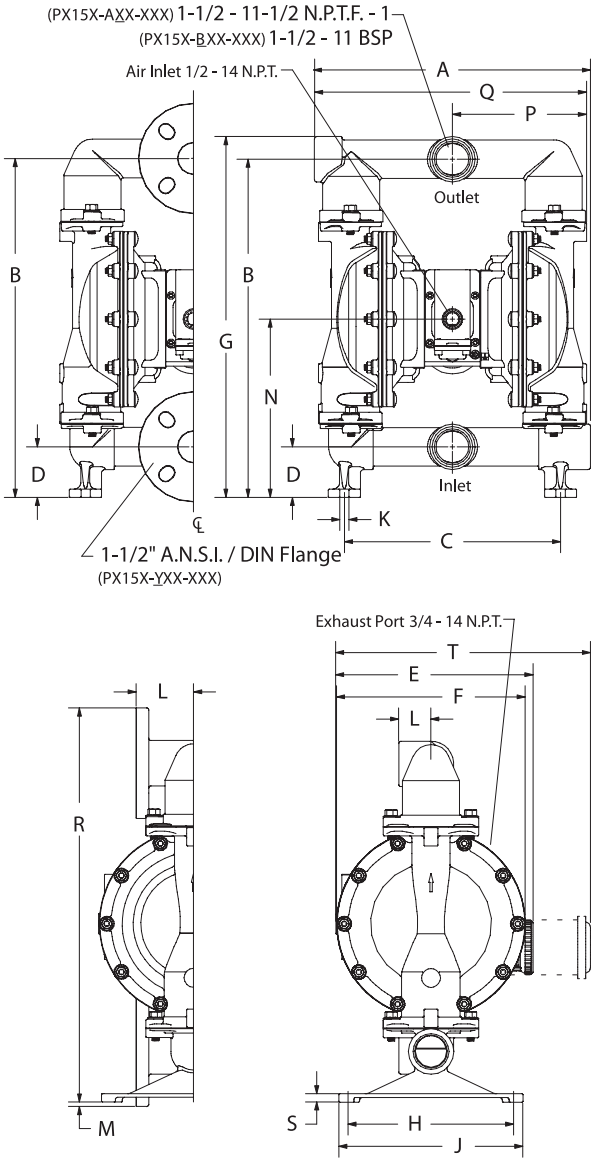

DIMENSIONS

- A - see below
- B - 18-3/8" (466.7 mm)
- C - 11-3/4" (298.5 mm)
- D - 2-3/4" (69.9 mm)
- E - see below
- F - 10-1/4" (260.4 mm)
- G - 19-5/8" (498.1 mm)
- H - 9" (228.6 mm)
- J - 10" (254.0 mm)
- K - 1/2" (12.7 mm)
- L - see below
- M - 1/4" (6.4 mm)
- N - 9-11/16" (246.0 mm)
- P - see below
- Q - see below
- R - 21-7/16" (543.9 mm)
- S - see below
- T - see below

	"A"	"L"	"P"	"Q"	"S"
PX15X-XAX-XXX	14-7/8" (377.8 mm)	1-3/4" (44.5 mm)	7-7/32" (183.4 mm)	14-23/32" (373.9 mm)	1/2" (12.7 mm)
PX15X-XCX-XXX	14-5/8" (371.5 mm)	1-3/4" (44.5 mm)	7-3/16" (182.6 mm)	14-1/2" (368.3 mm)	1/4" (6.4 mm)
PX15X-XHX-XXX	14-9/16" (370.0 mm)	3-1/8" (79.4 mm)	7-3/16" (182.6 mm)	14-1/2" (368.3 mm)	1/4" (6.4 mm)
PX15X-ASX-XXX, -BSX	14-25/32" (375.5 mm)	1-3/4" (44.5 mm)	7-9/32" (185.0 mm)	14-13/16" (375.5 mm)	15/32" (11.4 mm)
PX15X-YSX-XXX	14-9/16" (370.0 mm)	3-1/8" (79.4 mm)	7-9/32" (185.0 mm)	14-9/16" (370.0 mm)	15/32" (11.4 mm)

	"E"	"T"
PX15A-XXX-XXX	-----	14-1/32" (356.2 mm)
PX15B-XXX-XXX	11-3/32" (281.3 mm)	-----
PX15S-XXX-XXX	-----	13-27/32" (351.4 mm)

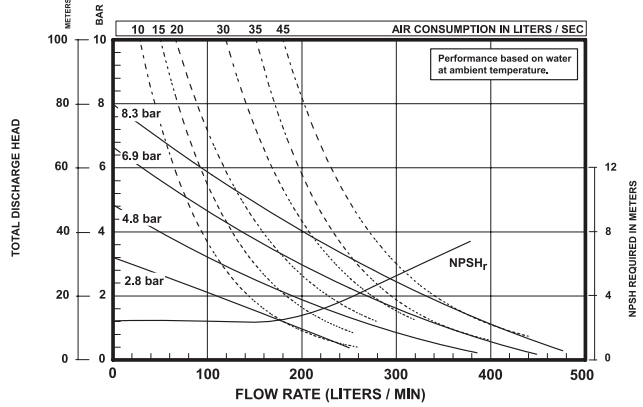
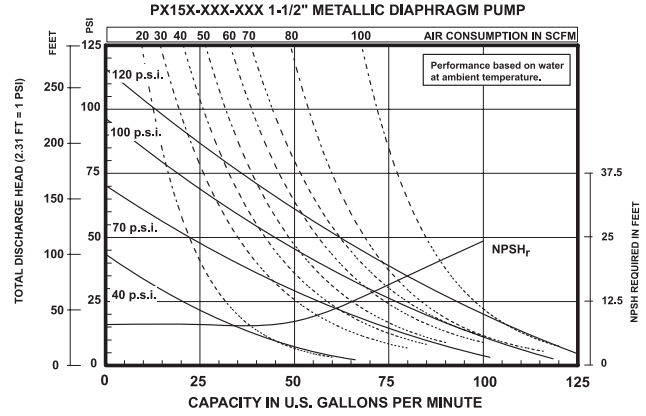

Refer to www.irtools.com/ARO for full size flow curves.

For additional information contact technical support at (800)495-0276

METALLIC