







ARO

Piston Pumps

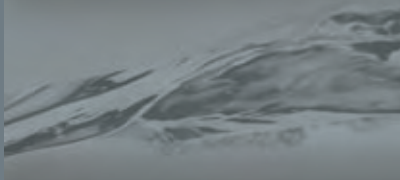

Pump Selection		4
Piston Pump Packages		10
Piston Pump Accessories		31
Dispense Equipment		68
2-Ball Pump Models		72
4-Ball Pump Models		98
Chop-Check Pump Models		104
Hydraulic Pumps		121

Progress in Motion



Ingersoll Rand / ARO piston pumps have been used for decades to increase productivity and minimize the costs associated with transferring, extruding, and applying a wide range of fluids and semi-fluid materials.

No matter what your product, process, or location, Ingersoll Rand / ARO offers a broad range of pumps and accessories, dispensing systems, and a worldwide distribution and service network prepared to solve your fluid handling challenges.

ARO piston pumps combine industry-proven dependability and economy to effectively deliver a wide range of materials. The efficient, simple design and construction of ARO piston pumps are the reason they are recognized as one of the most dependable and versatile pump lines on the market.

Fast cycling is a pump's greatest enemy. It aggravates wear on pump packings and creates heat that accelerates degeneration. In short, it shortens the life of your pump. We've taken every step to avoid fast and excessive cycling in our piston pumps. Our pumps feature high displacement rates, so there's greater fluid delivery per cycle.

To reduce the harmful effects of abrasion, many ARO pumps have hard chrome-plated plunger rods. Many pump lower ends feature ARO's Ultra-Coating™ on the plunger rod and tube. This dramatically improves packing life and provides a significant reduction in abrasion and scoring of wear parts.

When you purchase an Ingersoll Rand / ARO piston pump, you're assured of getting the pump that's most compatible with your application. Several packing options are offered to maximize pump service life: Teflon® for corrosive fluids, ultra-high molecular weight polyethylene (UHMW-PE) for abrasive fluids, plus Teflon / UHMW-PE and UHMW-PE / leather combinations to meet specific application requirements.

Teflon is a registered trademark of the DuPont Company.

Pump Selection

With almost 80 years of fluid handling experience, ARO is capable of handling your current and future piston pump applications. Selecting the correct piston pump takes several simple steps. Let's begin with common applications for different types of pumps and conclude with selection examples.

Pump Types

ARO piston pumps can be divided into three categories: 2-ball pumps, 4-ball pumps and chop-check pumps. Each has characteristics that make it suitable for a given application.

2-Ball Pumps

These pumps feature two ball checks that control fluid flow. They are typically used with low-to-medium viscosity fluids up to 100,000 centipoise (cPs) with fluid delivery up to 18.1 gpm (68.6 lpm), depending on the application.



4-Ball Pumps

These pumps feature four ball checks that control fluid flow. They are typically used with low viscosity fluids up to 12,500 cPs with fluid delivery up to 32.8 gpm (124.0 lpm), depending on the application.



Chop-Check Pumps

These pumps feature flat checks that mechanically control fluid flow. They are typically used with medium-to-high viscosity fluids in excess of 1,000,000 cPs with fluid delivery up to 12.2 gpm (46.3 lpm), depending on the application.



Piston Pump Applications

Piston pumps are used in a wide variety of fluid handling applications. The majority of these can be broken into four different categories.

Transfer

Simple transfer involves moving a low-to-medium viscosity fluid from one location to another. 2-ball and 4-ball style pumps are most frequently used in transfer applications.

Extrusion

Extrusion involves using a piston pump to apply medium-to-high viscosity materials. Typical extrusion applications require accessories like rams and fluid regulators to meet customer requirements. Chop-check and 2-ball pumps are used in extrusion applications.

Coating Application

This involves application of a material by either spray or dipping. Coating applications use 2-ball and 4-ball pumps.

Measuring / Dispense

Measuring and dispense involves the delivery of a specified quantity of fluid on a repetitive basis. Measuring / dispense applications use 2-ball, 4-ball and chop-check pumps.

Ratio

Ratio is the effective area differential between the air motor piston and the lower end plunger rod. A 9:1 (nine-to-one) ratio indicates the pump air motor piston has nine times the effective area of the fluid handling piston.

Higher ratio pumps produce higher fluid pressures. In that way, they can either move higher viscosity fluids or transfer fluids longer distance.

At 100 psi of inlet pressure, a 3:1 pump produces 300 psi of fluid outlet pressure. A 9:1 pump would produce 900 psi of outlet fluid pressure, given the same air inlet.

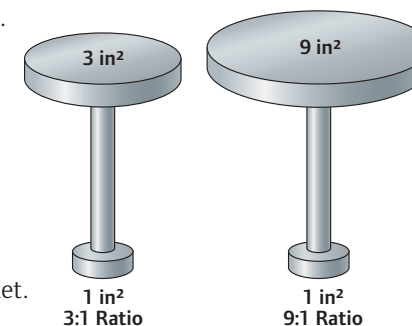

Materials of Construction

Pump components are constructed of different materials to ensure the pump is best suited to a particular application.

Pump Body Component Options

Stainless steel: Used with corrosive fluids and water-borne materials. Stainless steel is resistant to corrosion. It can be heat-treated, hard chrome-plated or Ultra-Coated™ to improve abrasion resistance.

Carbon steel: Provides excellent abrasion resistance. Can be heat-treated and hard chrome-plated. Not suited for water-borne fluids and corrosive materials, as it will rust and deteriorate.

Packings

Used to seal movement of the plunger rod. The upper (throat) packings seal the rod as it moves through the outlet casting. The lower (piston) packings seal the piston as it reciprocates within the pump body.

Packings are made of different materials to ensure chemical and material compatibility to maximize service life. Using packings of different material combinations can often improve service life by utilizing the strengths of both materials.

UHMW-PE (Ultra-High Molecular Weight Polyethylene):

An all-purpose packing material that provides excellent abrasion resistance. Commonly used with inks, acids and some solvents.

Teflon®*: Compatible with all fluids. Provides excellent corrosion resistance but poor abrasion resistance. Commonly used with corrosive chemicals, ketone, acids and room-temperature vulcanizing (RTV) materials.

Leather: Commonly used in combination with UHMW-PE packings for excellent sealing and abrasion resistance. UHMW-PE and leather is most often used when pumping ink.

*Teflon is a registered trademark of the DuPont Company

1 Fluid Information

Required Delivery Rate:

(Fluid delivery is generally measured in gallons or liters per minute;
In extrusion applications, this may be measured in grams, or ounces per minute)

Fluid Viscosity:

(Viscosity is normally listed in Centipoise)

Fluid Name:

Company Name:

(Who manufactured this material?)

Contact:

Phone:

2 Application Specifications

Indicate the type of application involved.

Basic Transfer:

Extrusion:

Coating Application:

Indicate how the pump will be mounted.

Wall Mount:

Floor Mount:

Cart or Ram:

3 Plumbing Information

Internal Diameter:

Plumbing Type:

(Ex: hose, tubing, hard piping)

Plumbing Length in Feet:

Rise of Plumbing:

(Vertical distance, if any)

Number of Drops:

4 Pressure Information

Air Pressure at Pump:

(Pressure at the pump may be considerably less than the shop line pressure)

Fluid Pressure Required at Drop:

(If specified by customer)

Pump Selection Checklist

When beginning the pump selection process, key information is required to select the appropriate pump for a given application. Completing the checklist on this page will prepare you to select the proper pump.

Use the data from the Checklist to complete the calculations on the following page.

Make copies of the Selection Checklist in advance. Keep the Checklist on hand when discussing pump selection with customers.

Having the Checklist completed is also required before contacting Technical Support at (800) 495-0276.

If you need assistance in sizing a pump for an application, don't hesitate to call Technical Support.

Pump Selection Support

Information to help you select the right piston pump can be obtained by contacting Technical Support.

► **Phone** 800-495-0276

► **Fax** 800-892-6276

► **E-mail** arohotline@irco.com

Back Pressure

Back pressure is the friction within a plumbing system that restricts fluid flow. Back pressure increases when fluids are more viscous or plumbing distance becomes greater. Other factors that contribute to back pressure include fluid filters, plumbing elbows and vertical piping rise.

► *Correctly determining back pressure is critical in pump selection. The following equation is used:*

$$\Delta P = \mu \times Q \times L \times .000245 \div (i.d.)^4$$

μ = fluid viscosity (centipoise)

Q = delivery required (gpm)

L = outlet plumbing length

.000245 = equation constant

$(i.d.)^4$ = plumbing internal diameter to the fourth power

► *With back pressure calculated, you can then determine pump ratio.*

$$\text{Required Ratio} = \Delta P \div \text{PSI}$$

ΔP = pressure drop within plumbing system

PSI = air pressure available at pump

► *Here is an example of calculating back pressure and pump ratio.*

$$\Delta P = \mu \times Q \times L \times .000245 \div (i.d.)^4$$

► *Plug in the components.*

μ = 25,000 cPs

Q = .25-gpm (1/4-gpm)

L = 150' total

$i.d.$ = .75 ($i.d.^4 = .3164$)

$$\Delta P = 25,000 \times .25 \times 150 \times .000245 \div .3164$$

$$\Delta P = 725.9 \text{ psi}$$

$$\text{Ratio} = \Delta P \div \text{PSI}$$

$$\Delta P = 725.9$$

$$\text{PSI} = 85 \text{ (at the pump)}$$

$$\text{Ratio} = 725.9 \div 85$$

$$\text{Ratio} = 8.54:1. \text{ Round up to } 9:1$$

Pump Selection Viscosity Charts

As the equations demonstrated, pumps are selected on the basis of overcoming back pressure within a plumbing system. The ARO Pump Viscosity Charts on the following pages can be used to match a pump with the fluid viscosity in question. A pump's ability to handle certain viscosities is affected by material properties and fluid temperature. Note that mounting has a direct impact on the fluid viscosity a pump can handle.

Wall and Cart Mounted (Siphon) Transfer Pumps

The pump is placed near the fluid container. It draws fluid from the container through a siphon hose or siphon tube. As the pump cycles, it draws material out of the container and into the pump.

Flooded Inlet

The pump is typically floor-mounted within 10 feet of a tank. The fluid flows from the bottom outlet of the tank to the pump inlet. This positive inlet pressure allows the pump to transfer higher viscosity fluids than a wall-mounted pump.

Cart Mounted Extrusion Pumps

The pump is attached to a follower plate, which is inserted into an open container. The weight of the pump and follower forces the material toward the pump inlet, allowing the transfer of higher-viscosity fluids.

Ram Mounted

The pump is attached to a follower plate. The ram pushes the pump and follower plate against the fluid, forcing the fluid into the pump. By forcing the pump into the container, it is possible to transfer even higher-viscosity fluids.

Pump-to-Fluid Viscosity Guide

Considerations: The chart should only be used as a guide, and not as an absolute solution to a pump problem. It does not take into consideration pressure losses due to sizes and lengths of hoses, piping runs, dispensing valves, hose swivels, elevations, and other restriction factors.

Flow	Maximum Delivery Rate gpm (L/min)	Ratio	Fluid Pressure Range psi (bar)	Pump Model Number	Material of Construction	Lower End Type	Pump on Page	500	1,000	5,000	7,500	10,000	12,500	15,000	20,000	35,000	50,000	75,000	100,000	250,000	500,000	750,000	1,000,000		
0 - 2	0.38 (1.4)	28:1	0 - 4200 (0 - 289.6)	NM2328A-11-X11	Stainless steel	2-ball	91	Siphon			Flooded inlet														
	0.5 (1.9)	22:1	0 - 3300 (0 - 227.5)	NM2322E-XX-P4X	Carbon steel	Chop-check	109				Flooded inlet						Ram Mounted								
	0.5 (1.9)	22:1	0 - 3300 (0 - 227.5)	NM2322F-XX-P4X	Stainless steel	Chop-check	110				Flooded inlet						Ram Mounted								
	0.74 (2.8)	43:1	0 - 6549 (0 - 451.5)	67120-P4X	Carbon steel	Chop-check	115				Flooded inlet						Ram Mounted								
	0.74 (2.8)	43:1	0 - 6549 (0 - 451.5)	67121-P4X	Stainless steel	Chop-check	116				Flooded inlet						Ram Mounted								
	0.74 (2.8)	43:1	0 - 6549 (0 - 451.5)	67124-P4X	Carbon steel	Chop-check	115				Flooded inlet						Ram Mounted								
	1.2 (4.5)	18:1	0 - 2700 (0 - 186.2)	NM2318B-13-C43	Stainless steel	2-ball	86	Siphon				Flooded inlet													
	1.3 (4.9)	30:1	900 - 4629 (62.1 - 319.2)	650485-X4X	Stainless steel	2-ball	92	Siphon				Flooded inlet					Ram Mounted								
	1.3 (4.9)	60:1	1800 - 6172 (124.1 - 425.5)	650685-X4X	Stainless steel	2-ball	96	Siphon				Flooded inlet					Ram Mounted								
	1.5 (5.7)	3.6:1 Hyd	180 - 4320 (12.4 - 297.9)	650935-C43-C	Carbon steel	Chop-check	129					Flooded inlet					Ram Mounted								
	1.6 (6.1)	3.3:1 Hyd	165 - 3394 (11.4 - 234)	650944-C43-B	Stainless steel	2-ball	128	Siphon				Flooded inlet					Ram Mounted								
	1.8 (6.8)	23:1	0 - 3690 (0 - 254.4)	650492-X43-B	Carbon steel	Chop-check	111					Flooded inlet					Ram Mounted								
	1.8 (6.8)	46:1	0 - 7485 (0 - 516.1)	650692-X43-B	Carbon steel	Chop-check	119					Flooded inlet					Ram Mounted								
	1.9 (7.2)	22:1	660 - 3412 (45.5 - 235.3)	650484-X4X	Stainless steel	2-ball	87	Siphon				Flooded inlet					Ram Mounted								
	1.9 (7.2)	45:1	1350 - 5459 (93.1 - 376.4)	650684-X4X	Stainless steel	2-ball	94	Siphon				Flooded inlet					Ram Mounted								
0 - 4	2.7 (10.2)	2.1 Hyd	100 - 2400 (6.9 - 165.5)	650934-X43-C	Carbon steel	Chop-check	127				Flooded inlet					Ram Mounted									
	2.9 (11)	9:1	0 - 1350 (0 - 93.1)	650409, 650409-4	Stainless steel	2-ball	79				Flooded inlet														
	2.8 (10.6)	9:1	0 - 1350 (0 - 93.1)	650453-X	Carbon steel	2-ball	80				Flooded inlet														
	2.9 (11)	9:1	0 - 1350 (0 - 93.1)	650408-B, -X-B	Stainless steel	2-ball	78	Siphon																	
	3.1 (11.7)	0.58:1 Hyd	85 - 2054 (5.9 - 141.6)	650943-X4X-B	Stainless steel	2-ball	124	Siphon				Flooded inlet													
	3.2 (12.1)	23:1	0 - 4215 (0 - 290.6)	650691-X43-B	Carbon steel	Chop-check	112				Flooded inlet						Ram Mounted								
	3.2 (12.1)	12:1	0 - 2085 (0 - 143.8)	650491-X43-B	Carbon steel	Chop-check	106				Flooded inlet						Ram Mounted								
	3.7 (14)	11:1	330 - 1747 (22.8 - 120.5)	650483-X4X	Stainless steel	2-ball	83	Siphon				Flooded inlet					Ram Mounted								
	3.7 (14)	23:1	690 - 3495 (47.6 - 241)	650683-X4X	Stainless steel	2-ball	88	Siphon				Flooded inlet					Ram Mounted								
	3.7 (14)	40:1	1200 - 4697 (82.7 - 323.9)	650883-X4X-B	Stainless steel	2-ball	93	Siphon				Flooded inlet					Ram Mounted								
	3.8 (14.4)	44:1	1320 - 3964 (91 - 273.3)	650891-X4D-C	Carbon steel	Chop-check	118				Flooded inlet						Ram Mounted								
	4.1 (15.5)	2:1	0 - 300 (0 - 20.7)	650110-C, -1C	Carbon steel	2-ball	74	Siphon																	
	4 (15.1)	9:1	270 - 1350 (18.6 - 93.1)	650239	Carbon steel	2-ball	11					Cart Mounted Extrusion													
	4 (15.1)	9:1	270 - 1350 (18.6 - 93.1)	650239-1	Carbon steel	2-ball	11					Cart Mounted Extrusion													
	4 (15.1)	9:1	270 - 1350 (18.6 - 93.1)	650240	Carbon steel	2-ball	11					Cart Mounted Extrusion													
0 - 10	4.2 (15.9)	4:1	0 - 600 (0 - 41.4)	NM2304B-11-X11	Stainless steel	2-ball	76	Siphon								Ram Mounted									
	4.2 (15.9)	4:1	0 - 600 (0 - 41.4)	NM2304B-41-X11	Stainless steel	2-ball	76	Siphon			Flooded inlet														
	4.3 (16.3)	2:1	0 - 351 (0 - 24.2)	NM2202A-11-X31	Carbon steel	2-ball	75	Siphon																	
	4.3 (16.3)	2:1	0 - 351 (0 - 24.2)	NM2202A-41-X31	Carbon steel	2-ball	75	Siphon				Flooded inlet													
	4.3 (16.3)	2:1	0 - 351 (0 - 24.2)	NM2202B-11-X31	Stainless steel	2-ball	75	Siphon																	
	4.3 (16.3)	2:1	0 - 351 (0 - 24.2)	NM2202B-41-X31	Stainless steel	2-ball	75	Siphon				Flooded inlet													
	4.4 (16.7)	4:1	0 - 600 (0 - 41.4)	NM2304A-11-X11	Carbon steel	2-ball	76	Siphon									Ram Mounted								
	4.4 (16.7)	4:1	0 - 600 (0 - 41.4)	NM2304A-41-X11	Carbon steel	2-ball	76	Siphon				Flooded inlet													
	5.4 (20.4)	45:1	1350 - 4050 (93.1 - 279.2)	650863-X4D-B	Carbon steel	2-ball	95	Siphon				Flooded inlet					Ram Mounted								
	5.4 (20.4)	65:1	1950 - 5850 (134.5 - 403.3)	650963-X4D-B	Carbon steel	2-ball	97	Siphon				Flooded inlet					Ram Mounted								
	6 (22.7)	28:1	840 - 3360 (57.9 - 231.7)	650888-XXX	Carbon steel	Chop-check	113					Flooded inlet					Ram Mounted								
	6 (22.7)	44:1	1320 - 3960 (91 - 273)	650889-XXX	Carbon steel	Chop-check	117					Flooded inlet					Ram Mounted								
	6 (22.7)	65:1	1950 - 5850 (134.5 - 403.3)	650989-XXX	Carbon steel	Chop-check	120					Flooded inlet					Ram Mounted								
	8.7 (32.9)	1.2:1 Hyd	60 - 2670 (4.1 - 184.1)	650941-XXE-C	Carbon steel	Chop-check	126					Flooded inlet					Ram Mounted								
	0 - 20	12.2 (46.2)	13:1	390 - 1900 (26.9 - 131)	650871-XXE-C	Carbon steel	Chop-check	107				Flooded inlet					Ram Mounted								
12.2 (46.2)		20:1	600 - 2250 (41.4 - 155.1)	650875-XXE-C	Carbon steel	Chop-check	108				Flooded inlet					Ram Mounted									
12.2 (46.2)		30:1	900 - 3250 (62.1 - 224.1)	650971-XXE-C	Carbon steel	Chop-check	114				Flooded inlet					Ram Mounted									
12.9 (48.8)		0.8:1 Hyd	40 - 1600 (2.8 - 110.3)	650940-XXD-B	Stainless steel	2-ball	125	Siphon				Flooded inlet													
15 (56.8)		10:1	300 - 1200 (20.7 - 82.7)	613112-XXF-C	Stainless steel	2-ball	81	Siphon				Flooded inlet					Ram Mounted								
15 (56.8)		10:1	300 - 1200 (20.7 - 82.7)	650866-X6D-B	Stainless steel	2-ball	82	Siphon				Flooded inlet					Ram Mounted								
15 (56.8)		15:1	450 - 1350 (31 - 93.1)	613123-XXF-C	Stainless steel	2-ball	85	Siphon				Flooded inlet					Ram Mounted								
15 (56.8)		15:1	450 - 1350 (31 - 93.1)	650867-X6D-B	Stainless steel	2-ball	84	Siphon				Flooded inlet					Ram Mounted								
17 (64.4)		0.3:1 Hyd	15 - 386 (1 - 26.6)	650949-X4B	Stainless steel	4-ball	123	Siphon				Flooded inlet													
18 (68.1)		1:1	0 - 150 (0 - 10.3)	612041-X	Carbon steel	2-ball	73	Siphon																	
18.1 (68.5)		23:1	690 - 2070 (47.6 - 142.7)	613124-XXF-C	Stainless steel	2-ball	90	Siphon				Flooded inlet													
18.1 (68.5)		23:1	690 - 2070 (47.6 - 142.7)	650967-X6D-B	Stainless steel	2-ball	89	Siphon				Flooded inlet													
0 - 35		21.3 (80.6)	2:01	60 - 312 (4.1 - 21.5)	650439-X4B	Stainless steel	4-ball	99	Siphon				Flooded inlet												
		21.3 (80.6)	4:01	120 - 633 (8.3 - 43.6)	650639-X4B	Stainless steel	4-ball	101	Siphon				Flooded inlet												
		22.4 (84.8)	0.2:1 Hyd	10 - 278 (0.7 - 19.2)	650950-X4B	Stainless steel	4-ball	122	Siphon				Flooded inlet												
	23.5 (89)	7:01	210 - 1009 (14.5 - 69.6)	650839-X4G-B	Stainless steel	4-ball	103	Siphon				Flooded inlet													
	29.3 (110.9)	3:01	90 - 457 (6.2 - 31.5)	650640-X4B	Stainless steel	4-ball	100	Siphon				Flooded inlet													
	32.8 (124.2)	5:01	150 - 702 (10.3 - 48.4)	650840-X4G-B	Stainless steel	4-ball	102	Siphon				Flooded inlet													

Piston Pump Packages



Most fluid handling applications require more than just a pump, but ordering extra equipment can take extra time and effort. ARO offers a series of transfer, extrusion and finishing packages that take the work out of the ordering process, allowing you to focus on other tasks.

Talk about a win / win scenario: ARO piston pump packages provide the pump, mount and follower (where applicable). Simply attach an air hose, connect to the fluid source, attach a fluid outlet line and begin pumping.

ARO packages fit a wide range of applications. Extrusion packages are designed to deliver high-viscosity sealers, mastics and ink. These feature 2-ball and chop-check pumps mounted on carts, lifts and rams. The result is an extensive offering of packages for extrusion applications. ARO accessories, like downstream fluid regulators, round out a pumping system and dial in an application.

Other packages are designed to apply coatings and finishes. These are available with pumps of different ratios, allowing you to apply tough primers, heavy coatings or finer finishes. Stainless steel pumps are designed for water-borne fluids, whether you use air-assisted airless or airless fluid atomization. Packages with carbon-steel pumps are ideal for applying adhesives and sealers.

Extrusion Packages

9:1 Ratio, 5-Gallon Pail, Cart Mount

Model	Description
650239	CARBON-STEEL EXTRUSION PACKAGE
65814-B	Carbon-steel pump
651840-1	Carbon-steel follower plate
67075-1-B	Portable lift
650239-1	CARBON-STEEL EXTRUSION PACKAGE
65814-1B	Carbon-steel pump
651840-1	Carbon-steel follower plate
67075-1-B	Portable lift
650240	CARBON-STEEL EXTRUSION PACKAGE
65814-B	Carbon-steel pump
651840-1	Carbon-steel follower plate
65778	Portable lift
67075-1-B	Hose (includes hose, extrusion gun, and nozzle)



650239
Air Powered Lift ONLY — Not a Ram

Model	Air Inlet Pressure Range psi (bar)	Fluid Pressure Range psi (bar)	Flow @ 60 Cycles per Minute gpm (L/min)	Displacement per Cycle cu in	Lower Pump Material	Packings	Plunger Material	Air Motor	Air Motor Repair Kit	Lower Pump End Series	Lower Pump Repair Kit
650239	30 – 150 (2.1 – 10.3)	270 – 1350 (18.3 – 93.1)	2.9 (10.8)	11	Carbon steel	Thiokol leather	Carbon steel	65445-B	61268	65965	637058
650239-1	30 – 150 (2.1 – 10.3)	270 – 1350 (18.3 – 93.1)	2.9 (10.8)	11	Carbon steel	Teflon	Carbon steel	65445-B	61268	65965-1	637059
650240	30 – 150 (2.1 – 10.3)	270 – 1350 (18.3 – 93.1)	2.9 (10.8)	11	Carbon steel	Thiokol leather	Carbon steel	65445-B	61268	65965	637058

22:1 Ratio, 5-Gallon Pail, Cart Mount

Model	Description
NP322L01-1 CARBON-STEEL EXTRUSION PACKAGE (LIFT)	
NM2322E-11-P43	Carbon-steel pump
P29122-600	Air filter/regulator
651840-1	Carbon-steel follower plate
67075-B	Portable lift
NP322L02-1 STAINLESS STEEL EXTRUSION PACKAGE (LIFT)	
NM2322F-11-P43	Stainless steel pump
P29122-600	Air filter/regulator with gauge
651841-1	Stainless steel follower plate
67075-B	Portable lift



NP322L01-1
Portable Lift ONLY
Not a Ram

Model	Air Inlet Pressure Range psi (bar)	Fluid Pressure Range psi (bar)	Maximum Working Flow gpm (L/min)	Displacement per Cycle cu in (cm ³)	Lower Pump Material	Plunger Material	Air Motor	Air Motor Repair Kit	Lower Pump End Series	Lower Pump Repair Kit
NP322L01-1	0 – 150 (0 – 10.3)	0 – 3,300 (0 – 227.6)	0.99 (3.7)	1.9 (31.1)	Carbon steel	17 – 4 stainless steel*	66915	637316	67100-P43	637290-P43
NP322L02-1	0 – 150 (0 – 10.3)	0 – 3,300 (0 – 227.6)	0.99 (3.7)	1.9 (31.1)	15 – 5 stainless steel	17 – 4 stainless steel*	66915	637316	67101-P43	637291-P43

*Hard chrome-plated.

43:1 Ratio, 5-Gallon Pail, Cart Mount

Model	Description
650540-1 CARBON-STEEL EXTRUSION PACKAGE	
67120-P43	Carbon-steel pump
651840-1	Carbon-steel follower plate
67075-B	Portable lift
650541-1 STAINLESS STEEL EXTRUSION PACKAGE	
67121-P43	Stainless steel pump
651841-1	Stainless steel follower plate
67075-B	Portable lift



650540-1
Air Powered Lift ONLY
Not a Ram

Model	Air Inlet Pressure Range psi (bar)	Fluid Pressure Range psi (bar)	Flow @ 60 Cycles per Minute gpm (L/min)	Displacement per Cycle cu in (cm ³)	Lower Pump Material	Plunger Material	Air Motor	Air Motor Repair Kit	Lower Pump End Series	Lower Pump Repair Kit
650540-1	0 – 150 (0 – 10.3)	0 – 6,549 (0 – 451.7)	0.74 (2.8)	2.8 (45.8)	Carbon steel	17 – 4 stainless steel*	65440	61268	67100-P43	637290-P43
650541-1	0 – 150 (0 – 10.3)	0 – 6,549 (0 – 451.7)	0.74 (2.8)	2.8 (45.8)	15 – 5 stainless steel	17 – 4 stainless steel*	65440	61268	67101-P43	637291-P43

*Hard chrome-plated.

4:1 Ratio, 5-Gallon Pail, Single-Post Ram

Model	Description
NP304R01-1 CARBON-STEEL EXTRUSION PACKAGE	
NM2304A-A1-C11	Carbon-steel pump
651840-1	Carbon-steel follower plate with polyurethane single-lipped seal
651615-1-D	Single-post ram
66713	Portability kit
NP304R01-2 CARBON-STEEL EXTRUSION PACKAGE	
NM2304A-A1-311	Carbon-steel pump
651840-1	Carbon-steel follower plate with polyurethane single-lipped seal
651615-1-D	Single-post ram
66713	Portability kit



NP304R01-2

Model	Air Inlet Pressure Range psi (bar)	Fluid Pressure Range psi (bar)	Flow @ 60 Cycles per Minute gpm (L/min)	Displacement per Cycle cu in (mL)	Lower Pump Material	Plunger Material	Air Motor	Air Motor Repair Kit	Lower Pump End Series	Lower Pump Repair Kit
NP304R01-1	0 – 150 (0 – 10.3)	0 – 600 (0 – 41.4)	2.1 (8.0)	8.2 (134.3)	Carbon steel	Carbon steel	66913	637316	67151-A-C11	637228
NP304R01-2	0 – 150 (0 – 10.3)	0 – 600 (0 – 41.4)	2.1 (8.0)	8.2 (134.3)	Carbon steel	Carbon steel	66913	637316	67151-A-311	637176

22:1 Ratio, 5-Gallon Pail, Single-Post Ram

Model	Description
NP322R01-1	CARBON-STEEL EXTRUSION PACKAGE (RAM)
NM2322E-11-P43	Carbon-steel pump
F25241-100	Air filter
R27241-600	Air regulator
651840-1	Carbon-steel follower plate
651615-D	Single-post ram
67189	Hold-down kit
66713	Optional portability kit
NP322R02-1	STAINLESS STEEL EXTRUSION PACKAGE (RAM)
NM2322F-11-P43	Stainless steel pump
F25241-100	Air filter
R27241-600	Air regulator
651841-1	Stainless steel follower plate
651615-D	Single-post ram
67189	Hold-down kit
66713	Optional portability kit



NP322R01-1
Portable Lift ONLY – Not a Ram

Model	Air Inlet Pressure Range psi (bar)	Fluid Pressure Range psi (bar)	Maximum Working Flow gpm (L/min)	Displacement per Cycle cu in (cm ³)	Lower Pump Material	Plunger Material	Air Motor	Air Motor Repair Kit	Lower Pump End Series	Lower Pump Repair Kit
NP322R01-1	0 – 150 (0 – 10.3)	0 – 3,300 (0 – 227.6)	0.99 (3.7)	1.9 (31.1)	Carbon steel	17 – 4 stainless steel*	66915	637316	67100-P43	637290-P43
NP322R02-1	0 – 150 (0 – 10.3)	0 – 3,300 (0 – 227.6)	0.99 (3.7)	1.9 (31.1)	15 – 5 stainless steel	17 – 4 stainless steel*	66915	637316	67101-P43	637291-P43

*Hard chrome-plated.

43:1 Ratio, 5-Gallon Pail, Single-Post Ram

Model	Description
650542-1	CARBON-STEEL EXTRUSION PACKAGE
67120-P43	Carbon-steel pump
651840-1	Carbon-steel follower plate with polyurethane wiper
651615-D	Single-post ram
67189	Hold-down kit
66713	Optional portability kit
650542-2	CARBON-STEEL EXTRUSION PACKAGE
67120-P43	Carbon-steel pump
651840-2	Carbon-steel follower plate with nitrile wiper
651615-D	Single-post ram
67189	Hold-down kit
66713	Optional portability kit
650543-1	STAINLESS STEEL EXTRUSION PACKAGE
67121-P43	Stainless steel pump
651841-1	Stainless steel follower plate with polyurethane wiper
651615-D	Single-post ram
67189	Hold-down kit
66713	Optional portability kit



650542-1

Model	Air Inlet Pressure Range psi (bar)	Fluid Pressure Range psi (bar)	Flow @ 60 Cycles per Minute gpm (L/min)	Displacement per Cycle cu in (cm ³)	Lower Pump Material	Plunger Material	Air Motor	Air Motor Repair Kit	Lower Pump End Series	Lower Pump Repair Kit
650542-1	0 – 150 (0 – 10.3)	0 – 6,549 (0 – 451.7)	0.74 (2.8)	2.8 (45.8)	Carbon steel	17 – 4 stainless steel*	65440	61268	67100-P43	637290-P43
650542-2	0 – 150 (0 – 10.3)	0 – 6,549 (0 – 451.7)	0.74 (2.8)	2.8 (45.8)	Carbon steel	17 – 4 stainless steel*	65440	61268	67100-P43	637290-P43
650543-1	0 – 150 (0 – 10.3)	0 – 6,549 (0 – 451.7)	0.74 (2.8)	2.8 (45.8)	15 – 5 stainless steel	17 – 4 stainless steel*	65440	61268	67101-P43	637291-P43

*Hard chrome-plated.

4:1 Ratio, 55-Gallon Drum, Two-Post Ram

Model	Description
67282-1 STAINLESS STEEL EXTRUSION PACKAGE	
NM2304B-41-311	Stainless steel pump
66516-6	Teflon-coated aluminum follower plate with polyurethane double-lipped seal
67289	Two-post ram
67282-2 CARBON-STEEL EXTRUSION PACKAGE	
NM2304A-11-311	Carbon-steel pump
66516-1	Aluminum follower plate with polyurethane double-lipped seal
67289	Two-post ram



67282-2

Model	Air Inlet Pressure Range psi (bar)	Fluid Pressure Range psi (bar)	Flow @ 60 Cycles per Minute gpm (L/min)	Displacement per Cycle cu in (mL)	Lower Pump Material	Plunger Material	Air Motor	Air Motor Repair Kit	Lower Pump End Series	Lower Pump Repair Kit
67282-1	0 – 150 (0 – 10.3)	0 – 600 (0 – 41.1)	2.1 (8.0)	8.2 (134.3)	316 stainless steel	316 stainless steel	66913	637316	65108	637010
67282-2	0 – 150 (0 – 10.3)	0 – 600 (0 – 41.1)	2.1 (8.0)	8.2 (134.3)	Carbon steel	Carbon steel	66913	637316	67151-1-C11	637176

22:1 Ratio, 55-Gallon Drum, Two-Post Ram

Model	Description
67283-1 STAINLESS STEEL EXTRUSION PACKAGE	
NM2322F-11-P43	Stainless steel pump
66516-6	Teflon-coated aluminum follower plate with polyurethane double-lipped seal
67289	Two-post ram
67283-2 CARBON-STEEL EXTRUSION PACKAGE	
NM2322E-11-P43	Carbon-steel pump
66516-1	Aluminum follower plate with polyurethane double-lipped seal
67289	Two-post ram
NP322R03-1 CARBON-STEEL EXTRUSION PACKAGE	
NM2322E-11-P43	Carbon-steel pump
66516-1	Aluminum follower plate with polyurethane double-lipped seal
651616-2	Two-post ram
NP322R03-2 STAINLESS STEEL EXTRUSION PACKAGE	
NM2322F-11-P43	Stainless steel pump
66516-6	Teflon-coated aluminum follower plate with polyurethane double-lipped seal
651616-52	Two-post ram



67283-2

Model	Air Inlet Pressure Range psi (bar)	Fluid Pressure Range psi (bar)	Flow @ 60 Cycles per Minute gpm (L/min)	Displacement per Cycle cu in (mL)	Lower Pump Material	Plunger Material	Air Motor	Air Motor Repair Kit	Lower Pump End Series	Lower Pump Repair Kit
67283-1	0 – 150 (0 – 10.3)	0 – 3,300 (0 – 227.6)	0.5 (1.9)	1.9 (31.1)	Stainless steel	17-4 stainless steel*	66915	637316	67101-P43	637291-P43
67283-2	0 – 150 (0 – 10.3)	0 – 3,300 (0 – 227.6)	0.5 (1.9)	1.9 (31.1)	Carbon steel	17-4 stainless steel*	66915	637316	67100-P43	637290-P43
NP322R03-1	0 – 150 (0 – 10.3)	0 – 3,300 (0 – 227.6)	0.5 (1.9)	1.9 (31.1)	Carbon steel	17-4 stainless steel*	66915	637316	67100-P43	637290-P43
NP322R03-2	0 – 150 (0 – 10.3)	0 – 3,300 (0 – 227.6)	0.5 (1.9)	1.9 (31.1)	Stainless steel	17-4 stainless steel*	66915	637316	67101-P43	637291-P43

*Hard chrome-plated.

43:1 Ratio, 55-Gallon Drum, Two-Post Ram

Model	Description
NP443EP43R4-12	CARBON-STEEL EXTRUSION PACKAGE
67124-P43	Carbon-steel pump
651840-3	Carbon-steel follower plate with Buna single-lip wiper
651613-D	Mini two-post ram



NP443EP43R4-12

Model	Air Inlet Pressure Range psi (bar)	Fluid Pressure Range psi (bar)	Flow @ 70 Cycles per Minute gpm (L/min)	Displacement per Cycle cu in (mL)	Lower Pump Material	Plunger Material	Air Motor	Air Motor Repair Kit	Lower Pump End Series	Lower Pump Repair Kit
NP443EP43R4-12	0 – 15 (0 – 10.3)	0 – 6,549 (0 – 451.7)	0.7 (2.8)	2.8 (45.8)	Carbon steel	17.2 stainless steel*	65440	61268	67100-P43	637290-P43

*Hard chrome-plated.

44:1 Ratio, 55-Gallon Drum, Two-Post Ram

Model	Description
NPB44R01-1	CARBON-STEEL EXTRUSION PACKAGE
650889-C4D	Carbon-steel pump
67196-1	Aluminum follower plate with neoprene tube-type seal
651616-17	Two-post ram



NPB44R01-1

Model	Air Inlet Pressure Range psi (bar)	Fluid Pressure Range psi (bar)	Flow @ 70 Cycles per Minute gpm (L/min)	Displacement per Cycle cu in (mL)	Lower Pump Material	Plunger Material	Air Motor	Air Motor Repair Kit	Lower Pump End Series	Lower Pump Repair Kit
NPB44R01-1	30 – 90 (2.1 – 6.2)	1,320 – 3,960 (91.0 – 273.1)	6.0 (22.9)	20.0 (327.7)	Carbon steel*	17-4 stainless steel**	66651-B	637110	67300-C4D	637348-C4D

*Nickel-plated.

**Hard chrome-plated.

45:1 Ratio, Two-Post Ram

Model	Description
NP645R01-1	STAINLESS STEEL EXTRUSION PACKAGE
650684-R43	Stainless steel pump
66516-7	Teflon-coated aluminum follower plate with EPR double-lipped seal
651616-53	Two-post ram
NP645R02-1	STAINLESS STEEL EXTRUSION PACKAGE
650684-R43	Stainless steel pump
67195-6	Teflon-coated aluminum follower plate with EPR tube-type seal
651616-57	Two-post ram



NP645R01-1

Model	Air Inlet Pressure Range psi (bar)	Fluid Pressure Range psi (bar)	Flow @ 60 Cycles per Minute gpm (L/min)	Displacement per Cycle cu in (mL)	Lower Pump Material	Plunger Material	Air Motor	Air Motor Repair Kit	Lower Pump End Series	Lower Pump Repair Kit
NP645R01-1	30 – 120 (2.1 – 8.3)	1,350 – 5,459 (93.0 – 376.3)	1.9 (7.3)	7.5 (122.9)	316 stainless steel	17-4 stainless steel*	65665-B	61355	66301-R43	637306-R43
NP645R02-1	30 – 120 (2.1 – 8.3)	1,350 – 5,459 (93.0 – 376.3)	1.9 (7.3)	7.5 (122.9)	316 stainless steel	17-4 stainless steel*	65665-B	61355	66301-R43	637306-R43

*Hard chrome-plated.

55-Gallon Extrusion Systems

Model	Pump Used	Follower Plate	Packings
NP421R-52-C43	21	52	C43
NP422R-02-G43	22	02	G43
NP424R-02-P43	24	02	P43
NP424R-52-343	24	52	343
NP424R-52-R43	24	52	R43
NP422R-53-R43	22	53	R43
NP424R-53-R43	24	53	R43
NP431R-02-C43	31	02	C43
NP431R-02-G43	31	02	G43
NP431R-02-P43	31	02	P43
NP431R-02-R43	31	02	R43
NP434R-02-343	34	02	343
NP434R-02-C43	34	02	C43
NP434R-02-G43	34	02	G43
NP434R-02-P43	34	02	P43
NP434R-02-R43	34	02	R43
NP434R-52-P43	34	52	P43



NP431R-02-P43

Code	Description
PUMPS	
21	30:1 2-ball Integrity pump (650485-X43)
22	22:1 2-ball Integrity pump (650484-X43)
24	11:1 2-ball Integrity pump (650483-X43)
31	23:1 chop-check (650492-X43-B)
34	12:1 chop-check (650491-X43-B)
FOLLOWER PLATES	
02	Aluminum follower plate with polyurethane double-lipped seal
52	Teflon-coated aluminum follower plate with polyurethane double-lipped seal
53	Teflon-coated aluminum follower plate with EPR double-lipped seal
PACKINGS	
343	Teflon (upper and lower)
C43	UHMW-PE (upper and lower)
G43	UHMW-PE / leather-staggered (upper and lower)
P43	UHMW-PE / leather-staggered (upper), UHMW-PE (lower)
R43	Teflon / UHMW-PE-staggered (upper), Teflon (lower)

Model	Pump Used	Follower Plate	Packings
NP621R-02-G43	21	02	G43
NP621R-52-R43	21	52	R43
NP622R-02-G43	22	02	G43
NP622R-53-R43	22	53	R43
NP622R-53-R4B	22	53	R4B
NP624R-02-C43	24	02	C43
NP624R-02-G43	24	02	G43
NP624R-02-P43	24	02	P43
NP624R-02-R43	24	02	R43
NP624R-52-R43	24	52	R43
NP631R-02-343	31	02	343
NP631R-02-C43	31	02	C43
NP631R-02-G43	31	02	G43
NP631R-02-P43	31	02	P43
NP631R-02-R43	31	02	R43
NP631R-13-P43	31	13	P43
NP631R-52-343	31	52	343
NP631R-52-G43	31	52	G43
NP631R-52-R43	31	52	R43
NP634R-02-C43	34	02	C43
NP634R-02-G43	34	02	G43
NP634R-03-R43	34	03	R43
NP634R-52-R43	34	52	R43

Code	Description
PUMPS	
21	60:1 2-ball Integrity pump (650685-X43)
22	45:1 2-ball Integrity pump (650684-X4X)
24	23:1 2-ball Integrity pump (650683-X43)
31	46:1 chop-check (650692-X43-B)
34	23:1 chop-check (650691-X43-B)
FOLLOWER PLATES	
02	Aluminum follower plate with polyurethane double-lipped seal
03	Aluminum follower plate with EPR double-lipped seal
13	Aluminum follower plate with EPR tube-type seal
52	Teflon-coated aluminum follower plate with polyurethane double-lipped seal
53	Teflon-coated aluminum follower plate with EPR double-lipped seal
PACKINGS	
343	Teflon (upper and lower)
C43	UHMW-PE (upper and lower)
G43	UHMW-PE / leather-staggered (upper and lower)
P43	UHMW-PE / leather-staggered (upper), UHMW-PE (lower)
R43	Teflon / UHMW-PE-staggered (upper), Teflon (lower)
R4B	Teflon / UHMW-PE-staggered (upper), Teflon (lower) with Ultra-Coated™ rod and tube



NP631R-02-C43

55-Gallon Extrusion Systems

Model	Pump Used	Follower Plate	Packings
NP834R-02-C4D	34	02	C4D
NP834R-02-G4D	34	02	G4D
NP834R-02-R4D	34	02	R4D
NP834R-52-R4D	34	52	R4D
NP836R-05-F4E	36	05	F4E



NP836R-05-F4E

Code	Description
PUMPS	
34	44:1 chop-check (650891-X4D-C)
36	13:1 chop-check (650871-XXE-C)
FOLLOWER PLATES	
02	Aluminum follower plate with polyurethane double-lipped seal
05	Aluminum follower plate with polyurethane double-lipped seal
52	Teflon-coated aluminum follower plate with polyurethane double-lipped seal
PACKINGS	
C4D	UHMW-PE (upper and lower)
G4D	UHMW-PE / leather-staggered (upper and lower)
R4D	Teflon / UHMW-PE-staggered (upper), Teflon (lower)
F4E	UHMW-PE / leather-staggered (upper), UHMW-PE (lower), multiple-wave spring

55-Gallon Extrusion Systems

Model	Pump Used	Follower Plate	Packings
NP834R-01-G4D	34	01	G4D
NP834R-01-R4D	34	01	R4D
NP834R-02-C4D	34	02	C4D
NP834R-02-G4D	34	02	G4D
NP834R-02-R4D	34	02	R4D
NP834R-52-R4D	34	52	R4D
NP836R-05-F4E	36	05	F4E

Code	Description
PUMPS	
34	44:1 chop-check (650891-X4D-C)
36	13:1 chop-check (650871-XXE-C)
FOLLOWER PLATES	
01	Aluminum follower plate with nitrile double-lipped seal
02	Aluminum follower plate with polyurethane double-lipped seal
05	Aluminum follower plate with polyurethane double-lipped seal
52	Teflon-coated aluminum follower plate with polyurethane double-lipped seal
PACKINGS	
C4D	UHMW-PE (upper & lower)
G4D	UHMW-PE / leather staggered (upper & lower)
R4D	Teflon / UHMW-PE staggered (upper), Teflon (lower)
F4E	UHMW-PE / leather staggered (upper), UHMW-PE (lower), multiple-wave spring

Adhesive Packages

9:1 Ratio, Drum-Mounted (55-gal)

Model	Description
NP409L01-1 STAINLESS STEEL DRUM-MOUNTED TRANSFER SYSTEM	
650409-1	Pump assembly
91790	Muffler
P29241-100	Piggyback
10067	Filter/regulator gauge
66197	Drum cover assembly
623600-10	Outlet hose
640067	Lift assembly
NP409L01-2 STAINLESS STEEL DRUM-MOUNTED TRANSFER SYSTEM	
650409-1	Pump assembly
91790	Muffler
P29241-100	Piggyback
10067	Filter/regulator gauge
66197	Drum cover assembly
623600-10	Outlet hose
640067	Lift assembly
651104-1	Agitator



NP409-L01-2

Model	Air Inlet Pressure Range psi (bar)	Fluid Pressure Range psi (bar)	Flow @ 60 Cycles per Minute gpm (L/min)	Displacement per Cycle cu in (cm ³)	Lower Pump Material	Plunger Material	Packing Material	Air Motor	Air Motor Repair Kit	Lower Pump Series	Lower Pump Repair Kit
NP409L01-1	0 – 150 (0 – 10.3)	0 – 1,350 (0 – 93.1)	6.2 (23.7)	11.0 (180.2)	316 stainless steel	316 stainless steel	UHMW-PE	65444-B	61268	65106-4	637010-4
NP409L01-2	0 – 150 (0 – 10.3)	0 – 1,350 (0 – 93.1)	6.2 (23.7)	11.0 (180.2)	316 stainless steel	316 stainless steel	UHMW-PE	65444-B	61268	65106-4	637010-4

28:1 Ratio, Cart-Mounted

Model	Description
NP328C01-2	STAINLESS STEEL CART-MOUNTED SYSTEM
NM2328A-11-S11	Stainless steel pump
P29122-100	Air filter/regulator
29850	Gauge
622581-6	Inlet hose assembly
651412	Material filter
NP328C02-2	STAINLESS STEEL CART-MOUNTED SYSTEM
NM2328A-11-S11	Stainless steel pump
P29122-100	Air filter/regulator
29850	Gauge
622581-6	Inlet hose assembly
651412	Material filter
628042-25	Outlet hose assembly
651533	Airless spray gun
TC1550	Spray nozzle
65030-5-B	Gun filter and swivel assembly



Model	Air Inlet Pressure Range psi (bar)	Fluid Pressure Range psi (bar)	Flow @ 60 Cycles per Minute gpm (L/min)	Displacement per Cycle cu in (cm ³)	Lower Pump Material	Plunger Material	Packing Material	Air Motor	Air Motor Repair Kit	Lower Pump Series	Lower Pump Repair Kit
NP328C01-2	0 – 150 (0 – 10.3)	0 – 4,200 (0 – 289.7)	0.38 (1.4)	1.4 (24.0)	440 stainless steel	440 stainless steel	UHMW-PE/ Glass-filled Teflon (staggered)	66914	637316	66066-3	637006-3
NP328C02-2	0 – 150 (0 – 10.3)	0 – 4,200 (0 – 289.7)	0.38 (1.4)	1.4 (24.0)	440 stainless steel	440 stainless steel	UHMW-PE/ Glass-filled Teflon (staggered)	66914	637316	66066-3	637006-3

28:1 Ratio, 5-Gallon Pail-Mounted

Model	Description
NP328D01-1	STAINLESS STEEL PAIL-MOUNTED AIRLESS PACKAGE
NM2328A-11-G11	Stainless steel pump
651412	Material filter assembly
65706	Cover
628042-25	Hose assembly
R27221-100	Air regulator
100067	Gauge
65722	Bucket
651533	Dispense valve
TC-1550	Nozzle
65030-5-B	Filter/swivel assembly
91296	Screen inlet cover
90273	Foot screen
NP328D01-2	STAINLESS STEEL PAIL-MOUNTED AIRLESS PACKAGE
NM2328A-11-S11	Stainless steel pump
651412	Material filter assembly
65706	Cover
628042-25	Hose assembly
R27221-100	Air regulator
100067	Gauge
65722	Bucket
651533	Dispense valve
TC-1550	Nozzle
65030-5-B	Filter/swivel assembly
91296	Screen inlet cover
90273	Foot screen



Model	Air Inlet Pressure Range psi (bar)	Fluid Pressure Range psi (bar)	Flow @ 60 Cycles per Minute gpm (L/min)	Displacement per Cycle cu in (cm ³)	Lower Pump Material	Plunger Material	Packing Material	Air Motor	Air Motor Repair Kit	Lower Pump Series	Lower Pump Repair Kit
NP328D01-1	0 – 150 (0 – 10.3)	0 – 4,200 (0 – 289.7)	0.38 (1.4)	1.4 (24.0)	Hardened stainless steel	Hardened stainless steel	UHMW-PE/ leather staggered	66914	637316	66066-2	637006-2
NP328D01-2	0 – 150 (0 – 10.3)	0 – 4,200 (0 – 289.7)	0.38 (1.4)	1.4 (24.0)	Hardened stainless steel	Hardened stainless steel	UHMW-PE/ Glass-filled Teflon staggered	66914	637316	66066-3	637006-3

28:1 Ratio, 5-Gallon Pail-Mounted

Model	Description
NP328D01-3 STAINLESS STEEL PAIL-MOUNTED AIRLESS PACKAGE	
NM2328A-11-G11	Stainless steel pump
651412	Material filter assembly
65706	Cover
65722	Bucket
NP328D01-4 STAINLESS STEEL PAIL-MOUNTED AIRLESS PACKAGE	
NM2328A-11-S11	Stainless steel pump
651412	Material filter assembly
65706	Cover
65722	Bucket
NP328D01-6 STAINLESS STEEL PAIL-MOUNTED AIRLESS PACKAGE	
NM2328A-11-S11	Stainless steel pump
651412	Material filter assembly
65706	Cover
N/A	Bucket



NP438001-3

Model	Air Inlet Pressure Range psi (bar)	Fluid Pressure Range psi (bar)	Flow @ 60 Cycles per Minute gpm (L/min)	Displacement per Cycle cu in (cm ³)	Lower Pump Material	Plunger Material	Packing Material	Air Motor	Air Motor Repair Kit	Lower Pump Series	Lower Pump Repair Kit
NP328D01-3	0 – 150 (0 – 10.3)	0 – 4,200 (0 – 289.7)	0.38 (1.4)	1.4 (24.0)	Hardened stainless steel	Hardened stainless steel	UHMW-PE/Leather staggered	66914	637316	66066-2	637006-2
NP328D01-4	0 – 150 (0 – 10.3)	0 – 4,200 (0 – 289.7)	0.38 (1.4)	1.4 (24.0)	Hardened stainless steel	Hardened stainless steel	UHMW-PE/Glass-filled Teflon staggered	66914	637316	66066-3	637006-3
NP328D01-6	0 – 150 (0 – 10.3)	0 – 4,200 (0 – 289.7)	0.38 (1.4)	1.4 (24.0)	Hardened stainless steel	Hardened stainless steel	UHMW-PE/Glass-filled Teflon staggered	66914	637316	66066-3	637006-3

28:1 Ratio, 5-Gallon Pail-Mounted

Model	Description
NP328D02-1 STAINLESS STEEL PAIL-MOUNTED AIRLESS PACKAGE	
NM2328A-11-G11	Stainless steel pump
651412	Material filter assembly
67506	Cover
628042-25	Hose assembly
R27221-100	Air regulator
100067	Gauge
650252	Agitator
65722	Bucket
651533	Airless spray gun
TC-1550	Spray nozzle
65030-5-B	Filter/swivel assembly
91296	Screen inlet cover
90273	Foot screen
NP328D02-2 STAINLESS STEEL PAIL-MOUNTED AIRLESS PACKAGE	
NM2328A-11-S11	Stainless steel pump
651412	Material filter assembly
67506	Cover
628042-25	Hose assembly
R27221-100	Air regulator
100067	Gauge
650252	Agitator
65722	Bucket
651533	Airless spray gun
TC-1550	Spray nozzle
65030-5-B	Filter/swivel assembly
91296	Screen inlet cover
90273	Foot screen



NP328D02-1

Model	Air Inlet Pressure Range psi (bar)	Fluid Pressure Range psi (bar)	Flow @ 60 Cycles per Minute gpm (L/min)	Displacement per Cycle cu in (cm ³)	Lower Pump Material	Plunger Material	Packing Material	Air Motor	Air Motor Repair Kit	Lower Pump Series	Lower Pump Repair Kit
NP328D02-1	30 – 150 (2 – 10.2)	840 – 4,200 (57.4 – 285.7)	0.38 (1.44)	1.47 (24)	Hardened stainless steel	Hardened stainless steel	UHMW-PE leather staggered	66914	637316	66066-2	637006-2
NP328D02-2	30 – 150 (2 – 10.2)	840 – 4,200 (57.4 – 285.7)	0.38 (1.44)	1.47 (24)	Hardened stainless steel	Hardened stainless steel	UHMW-PE/Glass-filled Teflon staggered	66914	637316	66066-3	637006-3

28:1 Ratio, Cart-Mounted

Model	Description
NP828C01-1	CARBON-STEEL CART-MOUNTED PACKAGE
650865-R4D-B	Carbon-steel pump
92460	Muffler
66554-2	Cart
66728	Inlet hose assembly
651533	Dispense valve
TC-1550	Nozzle
628042-25	Outlet hose assembly
651481-70-B	Material filter

Model	Air Inlet Pressure Range psi (bar)	Fluid Pressure Range psi (bar)	Flow @ 70 Cycles per Minute gpm (L/min)	Displacement per Cycle cu in (cm ³)	Lower Pump Material	Plunger Material	Packing Material	Air Motor	Air Motor Repair Kit	Lower Pump Series	Lower Pump Repair Kit
NP828C01-1	30 – 120 (2.1 – 8.3)	840 – 3,360 (57.9 – 231.7)	6.2 (23.7)	20.7 (339.2)	Carbon steel	17-4 stainless steel*	Teflon/UHMW-PE staggered (upper), Glass-filled Teflon (lower)	66523-B	66614	66475-R4D	637098-R43

*Hard chrome-plated.

30:1 Ratio, Cart-Mounted

Model	Description
650554	STAINLESS STEEL CART-MOUNTED PACKAGES
650485-P43	Stainless steel pump
R27241-100	Air line regulator
100067	Gauge
651422-70	Material filter
91790	Muffler
67140-1	5-gal. suction hose assembly
67138	Heavy-duty cart



650554

45:1 Ratio, Cart-Mounted

Model	Description
650556	STAINLESS STEEL CART-MOUNTED PACKAGES
650684-P43	Stainless steel pump
R27241-100	Air line regulator
100067	Gauge
651422-70	Material filter
91790	Muffler
67140-1	5-gal. suction hose assembly
67138	Heavy-duty cart



650556

Model	Air Inlet Pressure Range psi (bar)	Fluid Pressure Range psi (bar)	Flow @ 60 Cycles per Minute gpm (L/min)	Displacement per Cycle cu in (cm ³)	Lower Pump Material	Plunger Material	Packing Material	Air Motor	Air Motor Repair Kit	Lower Pump Series	Lower Pump Repair Kit
650554	30 – 150 (2.1 – 10.3)	900 – 4,500 (62.0 – 310.2)	1.3 (4.9)	5.5 (90.1)	CF8M stainless steel	17 – 4 stainless steel (chrome-plated)	UHMW-PE/Teflon staggered (upper), UHMW-PE (lower)	65465-B	61268	66302-P43	637307-P43
650556	30 – 120 (2.1 – 8.3)	1,350 – 5,459 (93.0 – 376.3)	1.9 (7.3)	7.5 (122.9)	CF8M stainless steel	17 – 4 stainless steel (chrome-plated)	UHMW-PE/Teflon staggered (upper), UHMW-PE (lower)	65665-B	61355	66301-P43	637306-P43

60:1 Ratio, Cart-Mounted

Model	Description
650556-1	STAINLESS STEEL CART-MOUNTED PACKAGE
650685-P43	Stainless steel pump
R27241-100	Air line regulator
100067	Gauge
651422-70	Material filter
91790	Muffler
67140-1	5-gal. suction hose assembly
67138	Heavy-duty cart



650556-1

Model	Air Inlet Pressure Range psi (bar)	Fluid Pressure Range psi (bar)	Flow @ 60 Cycles per Minute gpm (L/min)	Displacement per Cycle cu in (cm ³)	Lower Pump Material	Plunger Material	Packing Material	Air Motor	Air Motor Repair Kit	Lower Pump Series	Lower Pump Repair Kit
650556-1	30 – 100 (2.1 – 6.9)	1,800 – 6,000 (124.1 – 414.0)	1.4 (5.4)	5.5 (90.1)	CF8M (316) stainless steel	17-4 stainless steel (chrome-plated)	UHMW-PE/ Teflon staggered (upper), UHMW-PE (lower)	65665-B	61355	66302-P43	637307-P43

65:1 Ratio, Cart-Mounted

Model	Description
650919	CARBON-STEEL CART AND PUMP ASSEMBLY
650963-G4D-B	Carbon-steel pump
66718	Muffler
66554-2	Cart
66728	Inlet hose assembly
651481-70-B	Material filter

Model	Air Inlet Pressure Range psi (bar)	Fluid Pressure Range psi (bar)	Flow @ 70 Cycles per Minute gpm (L/min)	Displacement per Cycle cu in (cm ³)	Lower Pump Material	Plunger Material	Packing Material	Air Motor	Air Motor Repair Kit	Lower Pump Series	Lower Pump Repair Kit
650919	30 – 90 (2.1 – 6.2)	1,950 – 5,850 (134.5 – 403.4)	6.2 (23.7)	20.7 (339.2)	Carbon steel	17-4 stainless steel*	UHMW-PE/ Leather staggered	66506-B	637112	66475-G4D	637098-G43

*Hard chrome-plated.

Piston Pump Accessories

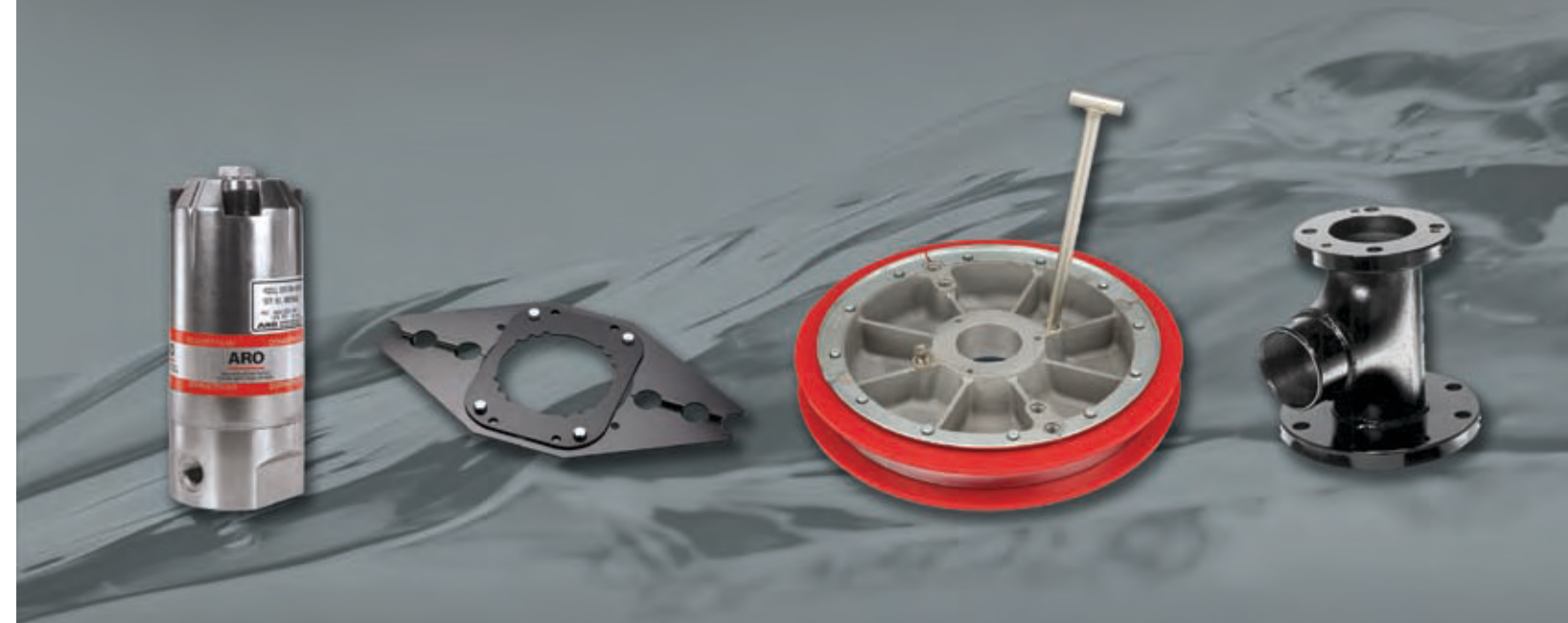

The Ingersoll Rand / ARO piston pump may be the heart of your fluid handling process, but the pump alone isn't enough to meet your application needs. You need additional equipment and this is where ARO's piston pump experience pays off for you.

ARO offers a complete range of accessories that improve pump performance and complete an application.

For transfer applications, you can find wall mounts, drum covers, and siphon hoses. To apply a coating, use ARO accessories like agitators, material filters, fluid heaters, and low-volume dispensing valves. To complete an extrusion application, there are rams, follower plates, fluid regulators, and extrusion guns and tips.

This section covers accessories that transform the pump from a commodity at the worksite to an integral part of your fluid handling system.

Accessories improve the efficiency of piston pump applications

Agitator

Air-driven devices that keep the material in suspension within the fluid container. Available for 5-gallon pails or 55-gallon drums.

Back Pressure Regulators

Regulators used on recirculating systems maintain pressures at a required level. Placed near the end of a recirculating system, the regulator allows fluid flow after the desired pressure is obtained.

Downstream Fluid Regulators

Used to control fluid pressure at the dispense point, downstream regulators cut fluid pressure to the desired level. They also help eliminate pulsation to provide more consistent flow of material.

Drum Covers

These help protect fluid from contamination and are available in carbon or stainless steel. For 5-gallon pails or 55-gallon drums.

Extrusion Guns

Used to dispense fluids with viscosities above 200,000 cPs. ARO Extrusion Guns are available in manual or automatic configurations. "Snuff-back" models reduce drippage of fluid at the worksite.

Extrusion Nozzle Kit

For manual or automatic extrusion guns — size of orifice diameter controls size of bead extruded from the gun.

Fluid Heaters

Use of a heater can lower fluid viscosities and produce uniform flow. Our heaters feature a cast aluminum body with stainless fluid passages. Available with various voltages, they have flow capacities of 15 gph (56.8 L/hr) at 100° F (38° C) above ambient.

Floor Mounts

Floor mounts are used when fluid is stored in bulk or tote tanks. Gravity feeds material into the pump inlet. Locate as close to fluid container as possible.

Follower Plates

Follower plates mount directly to the pump inlet. They seal the container and direct viscous fluid toward the pump inlet. Available for 5-gallon pails and 55-gallon drums.

Follower Plate Wipers

Forms seal point between the follower plate and container wall. Available in single-lip or double-lip models. Use single-lip wipers for viscosities up to 300,000 cPs. Double-lip wipers provide better wiping action on higher viscosity fluids. Tube-type wipers also available for use with 55-gallon drums.

Lifts

Lifts ease change-over of empty containers. An internal cylinder lifts the pump from the container. The weight of the air motor, pump, and mounting bracket maintain pump prime. Available for 5-gallon pails and 55-gallon drums.

Material Filters

These filters are used to strain particles from fluid that would otherwise clog downstream equipment.

Portability Kits

For single-post ram mounted pumps. Wheels and brackets bolt onto the base of the ram, easing portability around application site.

Rams

Rams function like lifts, but also exert downward force. Air cylinders on the ram push the pump and follower plate into the fluid. Available in single-post and two-post configurations; they are used with medium- to high-viscosity fluids. Rams are used with 5-gallon pails and 55-gallon drums.

Siphon Tubes / Hoses

A siphon tube or hose is used to draw material from the original container to the pump inlet. Because only the hose is immersed, the pump stays clean.

Wall Mounts

Used to mount pumps away from the fluid container — a clean, efficient mounting system that provides easy change-over when the fluid container is empty. Siphon used to connect pump to fluid container.

Lifts

When fluids are too viscous to flow easily, extra steps are needed to keep a pump primed. That's where a lift or ram comes into play.

Lifts are used to mount the pump above the fluid container. The weight of the pump and mounting bracket forces the pump into the fluid to keep it primed. An internal cylinder then lifts the pump from an empty container.

Portable Lifts

Part Number	Description
67075-X-B	PORTABLE LIFT
	For use with 5-gallon pails containing fluids with viscosities up to 200,000 cPs. A needle valve allows the operator to control the speed at which the pump is raised and lowered.
Usage Parameters	<ul style="list-style-type: none"> • 67075-B is used with the 650540-1, 650541-1, and NP322LOX-X models • 67075-1-B is used with the 650239, 650239-1, and 650240 models
Dimensions	Base: 26-19/32" (675.5 mm) x 27-1/2" (698.5 mm) Height: 42-59/64" (1090.2 mm) lowered



67075-B



640169

Stationary Lifts

Part Number	Description
640169	TWO-POST LIFT
	For use with 5-gallon and 55-gallon drums. Features two 2" (50.8 mm) diameter cylinders connected by a mounting bracket. Lift cylinders are bolted to floor.
Used With	<ul style="list-style-type: none"> • 4-1/4" and 6" air motor 2-ball, 4-ball and chop-check pumps • 66469 single-lip follower plate for 5-gallon drums • 66248 single-lip follower plate for 55-gallon drums
Dimensions	Height (lowered): 55-1/2" (1409.7 mm) Height (raised): 92-1/4" (2343.1 mm)
640067	SINGLE-POST LIFT
	For use with 55-gallon drums. Lift is bolted to floor. Support arms attach to drum cover. Lift is used to raise drum cover and bung-mounted pump. Use when pumping grease, oil and low-viscosity fluids.
Used With	<ul style="list-style-type: none"> • All 55-gallon bung-type pumps • 651852 or 66197 drum covers
Dimensions	Height (lowered): 55-1/2" (1409.7 mm) Height (raised): 92" (2336.8 mm)

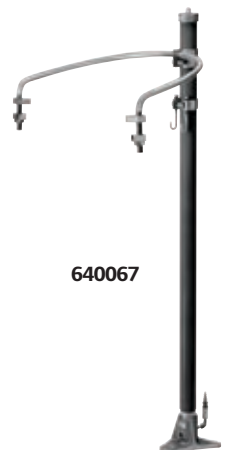

640067

Rams

Rams are used to force flowable, high-viscosity fluids into the pump inlet. They differ from a lift, in that a ram exerts downward force on a pump. Rams are available in single-post and two-post configurations for 5-gallon and 55-gallon containers.

Rams are often used with fluids with viscosities above 100,000 cPs. They are used on lower viscosity fluid if warranted by fluid characteristics. For example, if a fluid is stringy, a ram will be needed to keep the pump primed.

Single-Post Rams

Part Number	Description
651615-D	SINGLE POST RAM
Features	<ul style="list-style-type: none"> For use with 5-gallon drums and materials up to 1,000,000 cPs viscosity Hold-down clamps secure pail 66713 portability kit available for mobile applications
Used With	<ul style="list-style-type: none"> N Series 22:1 extrusion pumps 4-1/4" 43:1 extrusion pumps 4-1/4" and 6" air motor pumps except models listed for the 651613-D two-post ram
Dimensions	Base Dimensions: 19-3/4" (501.7 mm) x 24" (609.6 mm) Height Lowered: 59-5/32" (150.2 cm) Raised: 88-11/16" (225.2 cm)
651614-X	SINGLE POST RAM
Features	<ul style="list-style-type: none"> For use with 55-gallon drums Provides sufficient downforce to pump materials up to 500,000 cPs The 651614-X revolves 360 degree, allowing placement of three 55-gallon drums around the pump for applications that demand continuous material supply The ram includes brackets and hardware needed to accommodate 2-ball or chop-check pumps
Used With	<ul style="list-style-type: none"> 4-1/4", 6", 8", 10" & 12" air motor pumps Hydraulically driven pumps
Dimensions	Height Lowered: 63" (1600.2 mm) Raised: 110" (2794 mm)

Part Number	Fits ARO Pump	Height Raised	Height Lowered
651614-1	4-1/4" to 6" air motors	110"	63"
651614-2	8" to 12" air motors	110"	63"
651614-3	Small hydraulic motor	110"	63"
651614-4	Large hydraulic motor	110"	63"

The above models include the brackets and hardware needed to accommodate 2-ball or extrusion tie-rod pumps.



651615-D

Accessories:
66713 Portability Kit. Mounts directly to base of 651615-D ram to allow ease of portability.



651614-2

Part Number	Description
66713	PORTABILITY KIT
Features	<ul style="list-style-type: none"> Mounts directly to the base of the 651615-D ram to allow ease of portability; will clear 28" (711 mm) openings; has 12" (305 mm) tires 3" NPT(F) inlet 1/4" NPT(F) vent port with plug
Used with	651615-D single-post rams and ram packages

Part Number	Description
65116	FOLLOWER PLATE AIR ASSIST KIT
	Air assist valve supplies air pressure to bottom of follower plate to aid in bringing follower plate to top in less time; kit includes valve, hose, and necessary mounting hardware
Used with	651614-X single-post rams

Two-Post Rams

Part Number	Description
651616-X	STANDARD TWO-POST RAM
Features	<ul style="list-style-type: none"> Standard two-post ram for use with 5-gallon or 55-gallon drums For materials with viscosity over 200,000 cPs Features two 3-1/2" diameter air cylinders that are joined by cross-over tubes and welded to a steel base 651616-X Rams develop 0-to-4 psi (0-to-2.7 bar) downward force
Used With	<ul style="list-style-type: none"> N-Series, 4-1/4", 6", 8", 10" and 12" air motor pumps Cast aluminum follower plates Cast aluminum followers with Teflon coating
Dimensions	Base: 39-1/2" (1003 mm) x 24" (610 mm) Height Lowered: 61-11/32" (1.5 m) Raised: 99-1/32" (2.5 m) 4 mm)

Part Number	Follower Plate	Plate Style	Container	Mounting Footprint	Coating	Wiper Type	Wiper Material
651616-1	66516	Flat	55-gal	A	None	Double-lip	Nitrile
651616-2	66516-1	Flat	55-gal	A	None	Double-lip	Polyurethane
651616-3	66516-2	Flat	55-gal	A	None	Double-lip	EPR
651616-4	66517	Flat	55-gal	B	None	Double-lip	Nitrile
651616-5	66517-1	Flat	55-gal	B	None	Double-lip	Polyurethane
651616-6	66517-2	Flat	55-gal	B	None	Double-lip	EPR
651616-13	67195-2	Tapered	55-gal	A	None	Tube	EPR
651616-14	67195-1	Tapered	55-gal	A	None	Tube	Neoprene
651616-15	67195-3	Tapered	55-gal	A	None	Tube	Viton
651616-16	67196-2	Tapered	55-gal	B	None	Tube	EPR
651616-17	67196-1	Tapered	55-gal	B	None	Tube	Neoprene
651616-18	67196-3	Tapered	55-gal	B	None	Tube	Viton
651616-52	66516-6	Flat	55-gal	A	Teflon	Double-lip	Polyurethane
651616-53	66516-7	Flat	55-gal	A	Teflon	Double-lip	EPR
651616-55	66517-6	Flat	55-gal	B	Teflon	Double-lip	Polyurethane
651616-57	67195-6	Tapered	55-gal	A	Teflon	Tube	EPR
651616-58	67195-5	Tapered	55-gal	A	Teflon	Tube	Neoprene
651616-59	67195-7	Tapered	55-gal	A	Teflon	Tube	Viton
651616-60	67196-6	Tapered	55-gal	B	Teflon	Tube	EPR
651616-62	67196-7	Tapered	55-gal	B	Teflon	Tube	Viton

Mounting footprint is strictly a reference letter used to simplify the matching of pumps to follower plates and related accessories. For example, a pump with "A" mounting footprint will fit any accessory with "A" mounting footprint.

NOTE: Bare ram, no follower plate order part number 67081.

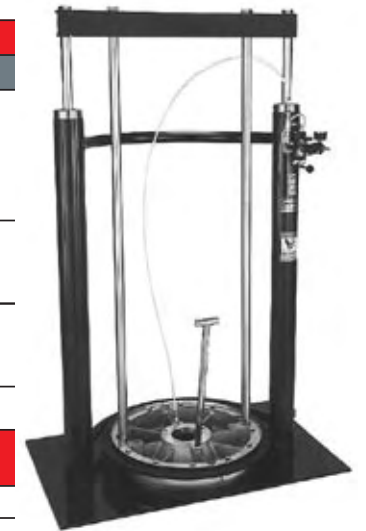

651616-X

Two-Post Rams

Part Number	Description
651612-X	HEAVY-DUTY TWO-POST RAM
Features	<ul style="list-style-type: none"> • Heavy-duty two-post ram for use with 55-gallon drums • Feature 5-1/2" diameter air cylinders that are joined by cross-over tubes and welded to a steel base • This extra downward force makes the ram ideal for highly viscous fluids that are also tacky or self-adhering • Examples include heavy inks, RTV silicones, caulking, varnishes, and adhesives • 651612-X Rams develop 0-to-11 psi (0-to-7.5-bar) downforce* • Drum hold-down bracket included
Used With	<ul style="list-style-type: none"> • 6", 8", 10" & 12" air motor pumps • Cast aluminum follower plates • Cast aluminum followers with Teflon coating
Dimensions	Base: 39-1/2" (1003 mm) x 24" (610 mm) Height Lowered: 61-3/4" (1568.4 mm) Raised: 99-13/16" (2535.2 mm)



651612-X

Part Number	Follower Plate	Plate Style	Container	Mounting Footprint	Coating	Wiper Type	Wiper Material
651612-1	66516	Flat	55-gal	A	None	Double-lip	Nitrile
651612-2	66516-1	Flat	55-gal	A	None	Double-lip	Polyurethane
651612-3	66516-2	Flat	55-gal	A	None	Double-lip	EPR
651612-4	66517	Flat	55-gal	B	None	Double-lip	Nitrile
651612-5	66517-1	Flat	55-gal	B	None	Double-lip	Polyurethane
651612-6	66517-2	Flat	55-gal	B	None	Double-lip	EPR
651612-7	67195-2	Flat	55-gal	A	None	Tube	EPR
651612-10	67196-2	Tapered	55-gal	B	None	Tube	EPR
651612-11	67196-1	Tapered	55-gal	B	None	Tube	Nitrile

NOTE: Bare ram, no follower plate order part number 651612.

**WARNING: Before using maximum follower plate down force, check container or consult container manufacturer for maximum pressure rating.*

Mounting footprint is strictly a reference letter used to simplify the matching of pumps to follower plates and related accessories. For example, a pump with an "A" mounting footprint will fit any accessory with an "A" mounting footprint.

Accessories

Part Number	Description
67133	DRUM HOLD-DOWN BRACKETS <ul style="list-style-type: none"> • Secures 55-gallon drum to 651616-XX two-post rams • Kit includes two brackets, clamp screws, and nuts • Holds empty fluid container in place during drum changeover
6635X-1	PUMP STABILIZING BRACKETS <ul style="list-style-type: none"> • For use with pumps mounted on 651616-XX two-post rams • Stabilizing bracket kits fit below air motor of pump and attach to the vertical pump support rods and the main cylinder rods of the ram • Stabilizing brackets support the air motor by relieving stress placed on fasteners securing pump to follower plate • Beneficial when rams are placed in a mobile application or when moved frequently within a plant
66353-1	For pumps with 8", 10", or 12" air motors
66354-1	For pumps with 4-1/4" or 6" air motors
67327	LOW LEVEL CUT-OFF <ul style="list-style-type: none"> • Used to shut off air supply to pumps mounted on two-post rams • For 651616-XX and 651612-X two-post rams and pumps with 10" (66651-B) and 12" (66506-B) air motors • Cut-off mounts to vertical support rod of ram • As material is dispensed and the ram lowers, the cut-off is activated, stopping air motor operation
IS431-A1	CROSS-OVER KIT <ul style="list-style-type: none"> • Maintains fluid delivery in extrusion systems • As first pump empties fluid container, the second pump is activated and fluid delivery is maintained • Kit can activate alarm to alert maintenance to change empty fluid container • For 651616-XX and 651612-X two-post rams



67133



66354-1



67327

Follower Plates

Follower plates seal the container and direct fluid toward the pump inlet. Pumps mount directly to the follower plate, which are sized for 5-gallon or 55-gallon containers. Follower plates with single-lip seals are designed for fluid viscosities up to 300,000 cPs. Use double-lip seals for viscosities over 300,000 cPs. Tube-type seals are also available for applications using 55-gallon drums.

Mounting Configurations

Mounting footprint is strictly a reference letter used to simplify the matching of pumps to follower plates and related accessories (i.e., a pump with an "A" mounting footprint will fit any accessory with an "A" mounting footprint).



Footprint A
Footprint used on 5-gallon follower plates, 55-gallon follower plates and 65138 mounting pedestal.

- Footprint matches the bolt configuration of flange inlet of chop-check lower ends.
- Footprint matches 67136 plate adapter for 2-ball pumps.



Footprint B
Footprint used on 55-gallon follower plates and mounting 67139 pedestal.

- Footprint matches the bolt configuration of flange inlet of chop-check lower ends.
- Footprint matches inlet for some large displacement 2-ball pumps.



Footprint C and D
Footprint fits 5-gallon pails, used with lifts and single-post rams.

- "C" designates slip-on connection to lower end.
- "D" designates 2" NPTF threads for use with Integrity style 2-ball lower ends.

Types of Follower Plates

ARO offers several types of follower plates for use with 5-gallon pails and 55-gallon drums. Standard, or flat, follower plates are used where fluid viscosities reach 500,000 to 750,000 cPs. High-viscosity, or tapered, follower plates are used where fluid viscosities that exceed 750,000 cPs.



Flat, Single-Lip Follower Plates
For 5-gallon pails and 55-gallon drums



Flat, Double-Lip Follower Plates
For 5-gallon pails and 55-gallon drums



Tapered, Tube-Type Follower Plates
For 55-gallon drums

5-Gallon Containers

Mounting footprint is strictly a reference letter used to simplify the matching of pumps to follower plates and related accessories. For example, a pump with an "A" mounting footprint will fit any accessory with an "A" mounting footprint.

Model	Material	Coating	Wiper Type	Wiper Material	Mounting Footprint	Used With
66469	Carbon steel	None	Single-lip	Nitrile	A	67075-X-B Cart/Lift 651613-D Two-post mini ram 651614-X Single-post ram 651615-D Single-post ram 651616-X Two-post ram
66731	Carbon steel	Electroless nickel	Double-lip	Nitrile	C	651615-D Single-post ram
66731-1	Carbon steel	Electroless nickel	Double-lip	Polyurethane	C	651614-X Single-post ram 651615-D Single-post ram 651616-X Two-post ram
66731-2	Carbon steel	Electroless nickel	Double-lip	EPR	C	651614-X Single-post ram 651615-D Single-post ram
66732	Carbon steel	Electroless nickel	Double-lip	Nitrile	A	651614-X Single-post ram 651615-D Single-post ram
66732-1	Carbon steel	Electroless nickel	Double-lip	Polyurethane	A	651614-X Single-post ram 651615-D Single-post ram Will fit metric pails
66732-2	Carbon steel	Electroless nickel	Double-lip	EP	A	651614-X Single-post ram 651615-D Single-post ram
651840-1	Carbon steel	None	290-mm Single-lip	Polyethylene / Urethane	C	67075-X-B Cart/Lift 651615-D Single-post ram
651840-2	Carbon steel	None	295-mm Single-lip	Nitrile	C	67075-X-B Cart/Lift 651615-D Single-post ram
651840-3	Carbon steel	None	311.9-mm for metric pails	Polyethylene / Urethane	C	67075-X-B Cart/Lift 651615-D Single-post ram
651841-1	Stainless steel	None	290-mm	Polyethylene / Urethane	C	67075-X-B Cart/Lift 651615-D Single-post ram
651842-1	Stainless steel	None	290-mm	Polyethylene / Urethane	D	651615-D Single-post ram
67342-1	Carbon steel	None	Single-lip (11.437")	Polyurethane / Polyethylene	A	651614-X Single-post ram 651615-D Single-post ram
67342-2	Carbon steel	None	Single-lip (295-mm)	Nitrile	A	651614-X Single-post ram 651615-D Single-post ram
67342-3	Carbon steel	None	Single-lip (312-mm)	Nitrile / Polyethylene	A	651614-X Single-post ram 651615-D Single-post ram
67345-1	Carbon steel	None	Single-lip (14.5")	Polyurethane / Polyethylene	A	651614-X Single-post ram 651615-D Single-post ram
67346-1	Carbon steel	None	Single-lip (14.5")	Polyurethane / Polyethylene	C	67075-X-B Cart/Lift 651615-D Single-post ram
67347-1	Aluminum	None	Tube	Neoprene	A	651614-X Single-post ram 651615-D Single-post ram
67347-11	Aluminum	Teflon	Tube	Neoprene	A	651614-X Single-post ram 651615-D Single-post ram
67347-2	Aluminum	None	Tube	EPR	A	651614-X Single-post ram 651615-D Single-post ram
67347-12	Aluminum	Teflon	Tube	EPR	A	651614-X Single-post ram 651615-D Single-post ram



66469



66732-1



651841-1



651842-1

Follower Plate Accessories

Part Number	Description
91364-10	SEAL PROTECTORS
Features:	<ul style="list-style-type: none"> Seals fit between follower plate and material to prevent corrosive fluids from attacking the follower plate wiper Reduces clean-up time, sold in packages of 10 Made of low-density polyethylene, 0.010" – 0.015" thick
Used With:	5-gallon follower plates
67136	FOLLOWER PLATE ADAPTER
Features:	<ul style="list-style-type: none"> For attaching Integrity 2-ball pumps to follower plates or 67138 floor mount; includes stainless steel adapter with 2" NPT(F) threads, seal, and hardware Mounting footprint "A"
Used With:	<ul style="list-style-type: none"> 651616-1, -2, -3 two-post rams 66248 and 66516 follower plates 65138 floor mount
67134	FOLLOWER PLATE ADAPTER
Features:	<ul style="list-style-type: none"> For attaching NM2322X- (22:1) and 6712X-X (43:1) ratio models
Used With:	<ul style="list-style-type: none"> 55-gallon follower plates and 67138 floor mount Mounting footprint "A"
90552	GASKET
Features:	<ul style="list-style-type: none"> Fits between follower plate and inlet of pump
Used With:	<ul style="list-style-type: none"> 67136-follower plate adapter Chop-check pumps that have footprint "A" style flange inlets
92339	GASKET
Features:	<ul style="list-style-type: none"> Fits between follower plate and inlet of pump
Used With:	<ul style="list-style-type: none"> Chop-check pumps that have footprint "B" style flange inlets



67136

55-Gallon Containers

Model	Material	Coating	Wiper Type	Wiper Material	Mounting Footprint	Used With
66248	Carbon steel	None	Single-lip	Nitrile	w/ polyethylene backup	640169 Two-post lift 651614-X Single-post ram
66248-1	Carbon steel	None	Single-lip	Polyethylene	A	640169 Two-post lift 651614-X Single-post ram
66516	Aluminum	None	Double-lip	Nitrile	A	651612-X Two-post ram 651614-X Single-post ram 651616-X Two-post ram
66516-1	Aluminum	None	Double-lip	Polyurethane	A	651614-X Single-post ram 651616-X Two-post ram
66516-2	Aluminum	None	Double-lip	EPR	A	651612-X Two-post ram 651614-X Single-post ram 651616-X Two-post ram
66516-5	Aluminum	Teflon	Double-lip	Nitrile	A	651612-X Two-post ram 651614-X Single-post ram 651616-X Two-post ram
66516-6	Aluminum	Teflon	Double-lip	Polyurethane	A	651612-X Two-post ram 651614-X Single-post ram 651616-X Two-post ram
66516-7	Aluminum	Teflon	Double-lip	EPR	A	651612-X Two-post ram 651614-X Single-post ram 651616-X Two-post ram
66517	Aluminum	None	Double-lip	Nitrile	B	651612-X Two-post ram 651614-X Single-post ram 651616-X Two-post ram
66517-1	Aluminum	None	Double-lip	Polyurethane	B	651612-X Two-post ram 651614-X Single-post ram 651616-X Two-post ram
66517-2	Aluminum	None	Double-lip	EP	B	651612-X Two-post ram 651614-X Single-post ram 651616-X Two-post ram
66517-5	Aluminum	None	Double-lip	Nitrile	B	651612-X Two-post ram 651614-X Single-post ram 651616-X Two-post ram
66517-6	Aluminum	None	Double-lip	Polyurethane	B	651612-X Two-post ram 651614-X Single-post ram 651616-X Two-post ram
66517-7	Aluminum	None	Double-lip	EPR	B	651612-X Two-post ram 651614-X Single-post ram 651616-X Two-post ram
67195-1	Aluminum	None	Tube	Neoprene	A	651612-X Two-post ram 651614-X Single-post ram 651616-X Two-post ram
67195-2	Aluminum	None	Tube	EPR	A	651612-X Two-post ram 651614-X Single-post ram 651616-X Two-post ram
67195-3	Aluminum	None	Tube	Viton	A	651612-X Two-post ram 651614-X Single-post ram 651616-X Two-post ram
67195-5	Aluminum	Teflon	Tube	Neoprene	A	651612-X Two-post ram 651614-X Single-post ram 651616-X Two-post ram
67195-6	Aluminum	Teflon	Tube	EPR	A	651612-X Two-post ram 651614-X Single-post ram 651616-X Two-post ram



66516



66517-1



67195-X

Mounting footprint is strictly a reference letter used to simplify the matching of pumps to follower plates and related accessories. For example, a pump with an "A" mounting footprint will fit any accessory with an "A" mounting footprint.

55-Gallon Containers

Model	Material	Coating	Wiper Type	Wiper Material	Mounting Footprint	Used With
67195-6	Aluminum	Teflon	Tube	EPR	A	651612-X Two-post ram 651614-X Single-post ram 651616-X Two-post ram
67195-7	Aluminum	Teflon	Tube	Viton	A	651612-X Two-post ram 651614-X Single-post ram 651616-X Two-post ram
67196-1	Aluminum	None	Tube	Nitrile	B	651612-X Two-post ram 651614-X Single-post ram 651616-X Two-post ram
67196-2	Aluminum	None	Tube	EPR	B	651612-X Two-post ram 651614-X Single-post ram 651616-X Two-post ram
67196-3	Aluminum	None	Tube	Viton	B	651612-X Two-post ram 651614-X Single-post ram 651616-X Two-post ram
67196-5	Aluminum	Teflon	Tube	Nitrile	B	651612-X Two-post ram 651614-X Single-post ram 651616-X Two-post ram
67196-6	Aluminum	Teflon	Tube	EPR	B	651612-X Two-post ram 651614-X Single-post ram 651616-X Two-post ram
67196-7	Aluminum	Teflon	Tube	Viton	B	651612-X Two-post ram 651614-X Single-post ram 651616-X Two-post ram

Mounting footprint is strictly a reference letter used to simplify the matching of pumps to follower plates and related accessories. For example, a pump with an "A" mounting footprint will fit any accessory with an "A" mounting footprint.



67195-X

Floor Stand Adapters/Seal Protectors

Part Number	Description
91363-10	SEAL PROTECTORS
Features:	<ul style="list-style-type: none"> • Seals fit between follower plate and material to prevent corrosive fluids from attacking the follower plate wiper • Reduces clean-up time, sold in packages of 10 • Made of low-density polyethylene, 0.010" - 0.015" thick
Used With:	• 55-gallon follower plates
67136	FOLLOWER PLATE ADAPTER
Features:	<ul style="list-style-type: none"> • For attaching Integrity 2-ball pumps to follower plates or 67138 floor mount; includes stainless steel adapter with 2" NPT (F) threads, seal, and hardware • Mounting footprint A
Used With:	<ul style="list-style-type: none"> • 651616-1, -2, -3 two-post rams • 66248 and 66516 follower plates • 65138 floor mount
67134	FOLLOWER PLATE ADAPTER
Features:	• For attaching NM2322X- (22:1) and 6712X-X (43:1) ratio models
Used With:	<ul style="list-style-type: none"> • 55-gallon follower plates and 67138 floor mount • Mounting footprint A
90552	GASKET
Features:	• Fits between follower plate and inlet of pump
Used With:	<ul style="list-style-type: none"> • 67136 follower plate adapter • Chop-check pumps that have footprint A style flange inlets
92339	GASKET
Features:	• Fits between follower plate and inlet of pump
Used With:	• Chop-check pumps that have footprint B style flange inlets



67136

Fluid Pressure Regulators

Ingersoll Rand / ARO I.D.L.[®] (Improved Design Line) Fluid Regulators feature smooth, consistent pressure regulation with easy-turn adjustment. Patented easy-access seat plug permits immediate service access to the regulator's ball and seat. Patented "floating" ball and seat design maintains proper regulation, even during significant fluctuations in line pressure.



3/8" Ports
(651780-A1A-B)

3/4" Ports
(651780-C1C-B)

3/8" Ports,
Remote Regulator
(651780-B1R-B)

Downstream Regulators

Model	Regulated Pressure Range psi (bar)	Maximum Inlet Pressure psi (bar)	Port Size	Housing Base	Seat	Gauge
651780-A1A-B	400 - 1,250 (27.6 - 86.2)	3,000 (206.9)	3/8"	Carbon steel	Tungsten carbide	No
651780-A1B-B	1,000 - 3,000 (69.0 - 206.9)	6,000 (413.8)	3/8"	Carbon steel	Tungsten carbide	No
651780-A3A-B	400 - 1,250 (27.6 - 86.2)	3,000 (206.9)	3/8"	300 Series stainless	Tungsten carbide	No
651780-A3B-B	1,000 - 3,000 (69.0 - 206.9)	6,000 (413.8)	3/8"	300 Series stainless	Tungsten carbide	No
651780-B1A-B	400 - 1,250 (27.6 - 86.2)	3,000 (206.9)	3/8"	Carbon steel	Tungsten carbide	No
651780-B1B-B	1,000 - 3,000 (69 - 206.9)	6,000 (413.8)	3/8"	Carbon steel	Tungsten carbide	No
651780-B1R-B	400 - 5,000 (27.6 - 344.8)	6,000 (413.8)	3/8"	Carbon steel	Tungsten carbide	No
651780-B3A-B	400 - 1,250 (27.6 - 86.2)	3,000 (206.9)	3/8"	300 Series stainless	Tungsten carbide	No
651780-B3B-B	1,000 - 3,000 (69 - 206.9)	6,000 (413.8)	3/8"	300 Series stainless	Tungsten carbide	No
651780-B3R-B	400 - 5,000 (27.6 - 344.8)	6,000 (413.8)	3/8"	300 Series stainless	Tungsten carbide	No
651780-C1B-B	750 - 2,500 (51.7 - 172.4)	6,000 (413.8)	3/4"	Carbon steel	Tungsten carbide	No
651780-C1C-B	2,000 - 5,000 (137.9 - 344.8)	6,000 (413.8)	3/4"	Carbon steel	Tungsten carbide	No
651780-C1R-B	750 - 5,000 (51.7 - 344.8)	6,000 (413.8)	3/4"	Carbon steel	Tungsten carbide	No
651780-C3B-B	750 - 2,500 (51.7 - 172.4)	6,000 (413.8)	3/4"	300 Series stainless	Tungsten carbide	No
651780-C3R-B	750 - 5,000 (51.7 - 344.8)	6,000 (413.8)	3/4"	300 Series stainless	Tungsten carbide	No

Downstream Regulators

Model	Regulated Pressure Range psi (bar)	Maximum Inlet Pressure psi (bar)	Port Size	Housing Base	Seat	Gauge	Pressure Range psi (bar)
651790-A1B-B	5 – 30 (0.3 – 2.1)	750 (51.7)	3/8"	Zinc	Tungsten carbide	93656-1	0 – 60 (0 – 4)
651790-A1C-B	20 – 60 (1.4 – 4.1)	750 (51.7)	3/8"	Zinc	Tungsten carbide	93656-1	0 – 60 (0 – 4)
651790-A1D-B	50 – 200 (3.4 – 13.8)	750 (51.7)	3/8"	Zinc	Tungsten carbide	93887	0 – 300 (0 – 20)
651790-A1R-B	30 – 200 (2.1 – 13.8)	750 (51.7)	3/8"	Zinc	Tungsten carbide	No gauge	N/A
651790-A3B-B	5 – 30 (0.3 – 2.1)	750 (51.7)	3/8"	300 Series stainless	Tungsten carbide	93657-1	0 – 60 (0 – 4)
651790-A3C-B	20 – 60 (1.4 – 4.1)	750 (51.7)	3/8"	300 Series stainless	Tungsten carbide	93657-1	0 – 60 (0 – 4)
651790-A3D-B	50 – 200 (3.4 – 13.8)	750 (51.7)	3/8"	300 Series stainless	Tungsten carbide	93888	0 – 300 (0 – 20)
651790-A3R-B	30 – 200 (2.1 – 13.8)	750 (51.7)	3/8"	300 Series stainless	Tungsten carbide	No gauge	N/A
651790-A4B-B	5 – 30 (0.3 – 2.1)	500 (34.5)	3/8"	300 Series stainless	300 Series stainless	93657-1	0 – 60 (0 – 4)
651790-A4C-B	20 – 60 (1.4 – 4.1)	500 (34.5)	3/8"	300 Series stainless	300 Series stainless	93657-1	0 – 60 (0 – 4)
651790-A4D-B	50 – 200 (3.4 – 13.8)	500 (34.5)	3/8"	300 Series stainless	300 Series stainless	93888	0 – 300 (0 – 20)
651790-A4R-B	30 – 200 (2.1 – 13.8)	500 (34.5)	3/8"	300 Series stainless	300 Series stainless	No gauge	N/A
651790-B1C-B	20 – 60 (1.4 – 4.1)	750 (51.7)	3/8"	Zinc	Tungsten carbide	93656-1	0 – 60 (0 – 4)
651790-B1D-B	30 – 200 (2.1 – 13.8)	1,250 (86.2)	3/8"	Zinc	Tungsten carbide	93887	0 – 300 (0 – 20)
651790-B1E-B	100 – 800 (6.9 – 55.2)	800 (55.2)	3/8"	Zinc	Tungsten carbide	93503-1	0 – 1,000 (0 – 70)
651790-B1R-B	30 – 200 (2.1 – 13.8)	500 (34.5)	3/8"	Zinc	Tungsten carbide	No gauge	N/A
651790-B2E-B	100 – 800 (6.9 – 55.2)	800 (55.2)	3/8"	300 Series stainless	400 Series stainless	93504-1	0 – 1,000 (0 – 70)
651790-B3D-B	30 – 200 (2.1 – 13.8)	1,250 (86.2)	3/8"	300 Series stainless	Tungsten carbide	93888	0 – 300 (0 – 20)
651790-B3E-B	100 – 800 (6.9 – 55.2)	1,250 (86.2)	3/8"	300 Series stainless	Tungsten carbide	93504-1	0 – 1,000 (0 – 70)
651790-B4D-B	30 – 200 (2.1 – 13.8)	500 (34.5)	3/8"	300 Series stainless	300 Series stainless	93888	0 – 300 (0 – 20)
651790-B4E-B	100 – 800 (6.9 – 55.2)	1,250 (86.2)	3/8"	300 Series stainless	300 Series stainless	93504-1	0 – 1,000 (0 – 70)
651790-B4R-B	30 – 200 (2.1 – 13.8)	500 (34.5)	3/8"	300 Series stainless	300 Series stainless	No gauge	N/A
651790-B5R-B	30 – 200 (2.1 – 13.8)	500 (34.5)	3/8"	300 Series stainless	300 Series stainless	No gauge	N/A



3/8" Ports, Standard Flow for 651790-A3D-B



3/8" Ports, Remote Model for 651790-A3R-B

1/4" Ports

Model	Regulated Pressure Range psi (bar)	Maximum Inlet Pressure psi (bar)	Port Size	Housing Base	Seat
27520-000	5 – 125 (0.3 – 8.5)	750 (51.7)	1/4"	Zinc	Tungsten carbide
27520-100	0 – 50 (0 – 3.4)	750 (51.7)	1/4"	Zinc	Tungsten carbide
27520-200	10 – 250 (0.6 – 17.1)	750 (51.7)	1/4"	Zinc	Tungsten carbide
27520-400	0 – 30 (0 – 2.0)	750 (51.7)	1/4"	Zinc	Tungsten carbide



27520-200

Back Pressure Regulators

Model	Regulated Pressure Range psi (bar)	Maximum Inlet Pressure psi (bar)	Port Size	Housing Base	Seat	Gauge	Pressure Range psi (bar)
651781-B1B-B	100 – 3,000 (6.9 – 206.9)	3,000 (206.9)	3/8"	Carbon steel	Tungsten carbide	No	
651781-B3B-B	100 – 3,000 (6.9 – 206.9)	3,000 (206.9)	3/8"	300 Series stainless	Tungsten carbide	No	
651781-C1B-B	100 – 3,000 (6.9 – 206.9)	3,000 (206.9)	3/4"	Carbon steel	Tungsten carbide	No	
651781-C3B-B	100 – 3,000 (6.9 – 206.9)	3,000 (206.9)	3/4"	300 Series stainless	Tungsten carbide	No	
651791-B1D-B	0 – 200 (0 – 13.8)	1,250 (86.2)	3/8"	Zinc carbide	Tungsten	93887	0 – 300 (0 – 20)
651791-B1E-B	0 – 800 (0 – 55.2)	800 (55.2)	3/8"	Zinc	Tungsten carbide	93503-1	0 – 1,000 (0 – 70)
651791-B3D-B	0 – 200 (0 – 13.8)	1,250 (86.2)	3/8"	300 Series stainless	Tungsten carbide	93888	0 – 300 (0 – 20)
651791-B3E-B	0 – 800 (0 – 55.2)	1,250 (86.2)	3/8"	300 Series stainless	Tungsten carbide	93504-1	0 – 1,000 (0 – 70)
651791-B4D-B	0 – 200 (0 – 13.8)	500 (34.5)	3/8"	300 Series stainless	300 Series stainless	93888	0 – 300 (0 – 20)
651791-C3D-B	0 – 200 (0 – 13.8)	200 (13.8)	1-1/4"	300 Series stainless	Tungsten carbide	93888	0 – 300 (0 – 20)
651791-C3D-B	0 – 200 (0 – 13.8)	200 (13.8)	1-1/4"	300 Series stainless	Tungsten carbide	93888	0 – 300 (0 – 20)
651791-C4D-B	0 – 200 (0 – 13.8)	200 (13.8)	1-1/4"	30.0 Series stainless	300 Series stainless	93888	0 – 300 (0 – 20)



3/8" Ports, (651781-B1B-B)



1-1/4" Ports (651791-B1E-B)

Part Number	Description
94806	MOUNTING BRACKET
Features:	<ul style="list-style-type: none"> Permits wall-mounting of I.D.L. downstream and back pressure fluid regulators Use of mounting bracket alleviates strain on plumbing system from weight of fluid and regulator
Used With:	<ul style="list-style-type: none"> 651780-X-B, 6517891-X-B, 651790-X-B and 651791-X-B fluid regulators, less remote models

Low-Pressure Gauges

Model	Material	Maximum Gauge Pressure psi (bar)	Thread Size	Used With
29975	Brass or aluminum	160 (11)	1/8" (M)	651780-X-B, 651781-X-B, 651790-X-B, and 651791-X-B regulators
29882	Brass or aluminum	60 (4)	1/8" (M)	651780-X-B, 651781-X-B, 651790-X-B, and 651791-X-B regulators
29883	Brass or aluminum	160 (11)	1/8" (M)	651780-X-B, 651781-X-B, 651790-X-B, and 651791-X-B regulators
100090	Brass	60 (4)	1/8" (M)	651780-X-B, 651781-X-B, 651790-X-B, and 651791-X-B regulators
65107	Stainless steel	0 – 100 (0 – 7)	1/4" (M)	651780-X-B, 651781-X-B, 651790-X-B, and 651791-X-B regulators
100067	Brass or aluminum	160 (11)	1/4" (M)	651780-X-B, 651781-X-B, 651790-X-B, and 651791-X-B regulators
100083	Brass or aluminum	300 (21)	1/4" (M)	651780-X-B, 651781-X-B, 651790-X-B, and 651791-X-B regulators
93504-1	Stainless steel	0 – 1,000 (0 – 70)	1/4" (M)	651780-X-B, 651781-X-B, 651790-X-B, and 651791-X-B regulators

High-Pressure Gauges

Model	Material	Maximum Gauge Pressure psi (bar)	Thread Size	Used With
93505-1	Rear-mounted, non-stainless steel	0 – 3,000 (0 – 204)	1/4" (M)	Required when attaching gauge to 651780-X-B and 651781-X-B high-pressure fluid regulators
93506-1	Rear-mounted, stainless steel	0 – 3,000 (0 – 204)	1/4" (M)	Required when attaching gauge to 651780-X-B and 651781-X-B high-pressure fluid regulators

High-Pressure Gauge Adapters

Model	Port Size	Type	Used With
92968	3/8"	Dual-outlet ports	Required when attaching gauge to 651780-X-B and 651781-X-B high-pressure fluid regulators, when using the 93505-1 and 93506-1 gauges
92969	3/4"	Single-outlet ports	Required when attaching gauge to 651780-X-B and 651781-X-B high-pressure fluid regulators, when using the 93505-1 and 93506-1 gauges

Part Number	Description
94806	MOUNTING BRACKET
Features	Permits wall-mounting of 651790-X-B, 651791-X-B, 651780-X-B, and 651781-X-B fluid regulators
Used With	Not for use with remote-style regulators

Manual Extrusion Guns

Model Number	Description	Max Fluid Pressure psi (bar)	Fluid Inlet in	Fluid Outlet I.D. & Thread in (mm)
651500	Flow Gun: Aluminum body with tungsten carbide seats. Order 66541-XX Extrusion Nozzle Kit separately. Used to extrude material over 200,000 cPs.	7500 (517)	3/8" (F)	1/4" (6) & 11/16-16 (M)
651533	Flow Gun: Wetted parts of 316 series stainless steel with tungsten carbide seats. Order 66541-XX Extrusion Nozzle Kit separately.	5000 (345)	1/4" NPS(M)	15/16" (2.3) & 11/16-16 (M)
641523-1	Flow Gun: Wetted parts of 300 Series stainless steel with Teflon packings. Order 76751 Adapter and 66541-XX Extrusion Nozzle Kit separately.	3000 (207)	3/8" (F)	1/4" (6) & 1/4" NPT(F)



651533



641523-1 (Shown with 66541-XX)

Automatic Extrusion Guns

Model Number	Description	Pumps Used With	Outlet Port Size in (mm)	Working Pressure psi (bar)
651511	Flow Gun: Requires 4-way air valve to open and close. Adjusting screw varies stroke length. Secures to 1/2" diameter rod by Allen screw. Aluminum body with tungsten carbide seats. Order 66541-XX Extrusion Nozzle Kit separately.	5000 (345)	3/8" NPT (F) (2)	1/4" (6) & 11/16-16 (M) (2) 1/8 F (138 bar) fluid pressure
651513-11-B	Flow Gun: Has air open, spring return actuator. Requires 3-way air valve to open. Adjusting screw varies stroke length. Secures to 1/2" diameter rod by Allen screw. 316 stainless steel body with tungsten carbide seat. Order 66541-XX Extrusion Nozzle Kit separately.	5000 (345)	1/4" NPS (M)	15/16" (2.3) & 11/16-16 (M) (F) 50 (3.4) at 2000 PSI (138 bar) fluid pressure
651536-1	Snuff-Back Gun: High flow automatic dispensing gun is designed to handle high-viscosity materials. Requires a 4-way air valve to open and close.	5000 (345)	3/8" NPT (F) (2)	1/4" NPT (F) (2) 1/8 NPT (F)
651537-1	Flow Gun: Similar to 651511 except with carbon-steel body and tungsten carbide ball and seat.	5000 (345)	3/8" NPT	3/8" (18 (M)) (2) 1/8 (138 bar) fluid pressure



651511



651513



651500

Extrusion Gun Nozzle Kits

Model Number	Orifice Diameter in (mm)	Model Number	Orifice Diameter in (mm)	Model Number	Orifice Diameter in (mm)
76751	Adapter: 1/4 NPT (M) to 11/16-16 (M) adapts 66541-XX Extrusion Nozzle Kit to fluid outlet for 641523-1 Flow Gun.				
66541-XX	Extrusion Nozzle Kit: Used on manual or automatic extrusion guns. Hardened steel assembly includes nozzle and cap. 11/16-16 UN(F).				
66541-3	0.031"	66541-9	0.093"	66541-17	0.172"
66541-4	0.046"	66541-12	0.125"	66541-18	0.187"
66541-6	0.063"	66541-15	0.156"	66541-25	0.250"
				66541-37	0.375"



66541-XX

Fluid Heaters and Accessories

Part Number	Volts AC	Amps	Heater watts	Heater Accuracy °F (°C)	Rise Over Ambient °F (°C)	Recovery gph (L)	Working Press psi (bar)	Inlet Outlet NPT
651747-1-B	120	16.6	2,000	+/- 3-1/2° (+/- 1.9°)	100° (38°)	15 (56.8)	5,000 (345)	1/2" (F)
651747-2-B	240	8.3	2,000	+/- 3-1/2° (+/- 1.9°)	100° (38°)	15 (56.8)	5,000 (345)	1/2" (F)
651747-3-B	440	4.5	2,000	+/- 3-1/2° (+/- 1.9°)	100° (38°)	15 (56.8)	5,000 (345)	1/2" (F)



651747-X-B

Part Number	Description
66258	MOUNTING BRACKET
Features	Bracket assembly with appropriate mounting holes to affix heater to vertical substrate
Used With	651747-X

Manual Airless Guns

Model Number	Description	Max Fluid Pressure psi (bar)	Fluid Inlet in	Fluid Outlet I.D. & Thread in (mm)
651533	Airless Gun: Wetted parts of 316 stainless steel with tungsten carbide seats. Used for airless application of paints, lacquets and other light fluids. Order TC-XXXX airless spray tip separately.	5,000 (345)	1/4" NPS(M)	15/16" (2.3) & 11/16-16 (M)
651500-1	Airless Gun: Aluminum body with tungsten carbide seats. Used for airless application of materials over 200,000 cPs. Includes 66504 tip guard and nut. Order TC-XXXX spray tip separately.	7500 (517)	3/8" NPT(F)	1/4" (6) & 11/16-16 (M)



651533



651500-1

Automatic Airless Guns

Model Number	Description	Max Fluid Pressure psi (bar)	Fluid Inlet in	Fluid Outlet I.D. & Thread in (mm)	Air Inlet/Outlet Inches NPT	Min. Air Pressure to open psi (bar)
651511-1	Airless Gun: Requires 4-way air valve to open & close. Adjusting screw varies stroke length. Secures to 1/2" diameter rod by Allen screw. Aluminum body with tungsten carbide seats. Includes 66504 tip guard and nut. Order TC-XXXX spray tip separately.	5000 (345)	(2) 3/8 NPT(F)	1/4" (6) & 11/16-16(M)	(2) 1/8 (F)	50 (3.4) at 2000-psi (138-bar) fluid pressure
651513-12-B	Airless Gun: Has air open, spring return cylinder. Requires 3-way air valve to open. Adjusting screw varies stroke length. Secure to 1/2" diameter rod with Allen screw. 316 stainless body with tungsten carbide seat. Includes 66504 tip guard and nut. Order TC-XXXX spray tip separately.	5000 (345)	(1) 1/4 NPS(M)	15/16" (2.3) & 11/16-16 (M)	(1) 1/8 (F)	50 (3.4) at 2000-psi (138-bar) fluid pressure



651511-1



651513-12-B

Airless Spray Tips

Part Number	-D Models	Equivalent Orifice	Pattern Width in (mm)	Flow Rate gpm @ Fluid psi			
				500	1,000	1,500	2,000
TC1325	-	0.013	5.5" (140)	0.09	0.12	0.15	0.18
TC1550	-D	0.015	10.0" (254)	0.12	0.16	0.1	0.23
TC1850	-D	0.018	10.0" (254)	0.18	0.25	0.3	0.36
TC1865	-D	0.018	13.0" (330)	0.18	0.25	0.3	0.36
TC1880	-D	0.018	15.0" (381)	0.18	0.25	0.3	0.36
TC2140	-D	0.021	8.5" (216)	0.24	0.33	0.41	0.47
TC2650	-D	0.026	12.0" (305)	0.35	0.5	0.61	0.71
TC3195	-	0.031	21.5" (546)	0.53	0.75	0.92	1.1
TC3650	-	0.036	12.0" (305)	0.71	1	1.2	1.4
TC4195	-	0.041	21.5" (546)	0.88	1.2	1.5	1.8
TC4340	-	0.043	9.0" (229)	1.1	1.5	1.8	2.1
TC4365	-	0.043	15.0" (381)	1.1	1.5	1.8	2.1
TC6265	-	0.062	15.0" (381)	2.1	3	3.7	4.2

Part Number	Description
66504	TIP GUARD AND NUT
Features	Secure TC-XXX tip to gun; guard required on airless applications. Order tips separately.
Used With	• All manual/automatic spray guns
651555-B	QUICK CLEAN
Features	Spray tip locked in operating position until reversed with lever for cleaning. For spraying heavy-viscosity material. Order separately.
Used With	• All manual/automatic spray guns
651551	QUICK CLEAN
Features	Spray tip locked in operating position until reversed with lever for cleaning. For spraying heavy-viscosity material. Order TC-XXXX spray tip separately.
Used With	• 651500-1 guns • NOTE: To adapt 651551 to fit 651533, order 76555 pilot, 92367 retaining nut, Y167-1-1/8" (M) x 1/4" (F) adapter
65030-1-B	SWIVEL
Features	1/4" NPT(M) x 1/4" NPS (F); swivels 360°. No filter included.
Used With	• All manual/automatic spray guns
65030-X-B	SWIVEL AND FILTER ASSEMBLY
Features	1/4" NPT(M) x 1/4" NPS(F); swivels 360°. 6700-psi (462.3-bar) maximum working pressure
Used With	• All manual / automatic spray guns
65030-1-B	Swivel, no filter
65030-5-B	Swivel, 100-mesh stainless steel filter
65030-9-B	Swivel, 60-mesh stainless steel filter

Model Number Descriptor

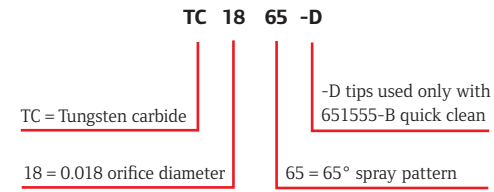

TC1850

Equivalent Orifice
Airless tip orifices are elliptical in shape. The term "equivalent orifice diameter" refers to the circular orifice diameter which will provide the same flow rate as the elliptical orifice. The equivalent orifice diameter does not indicate actual orifice dimensions.

Pattern Width
This dimension is the nominal pattern width of each tip when tested on a coating material of 20 seconds: Number 4 Zahn cup viscosity at 1,500 psi at a 12" distance from the tip.

Flow Rate in gpm
The flow rates of Ingersoll Rand / ARO Piston Pumps airless tips are given as gpm flow on water at pressures shown. Capacities will vary to some degree on other materials.



651555-B



651551



65030-1

Swivels

Model	Thread Size NPT x NPT in	Type of Seals	Max Working Pressure psi (bar)
STRAIGHT SWIVEL			
636075	1/8" (M) x 1/8" (F)	Fabric with neoprene	10,000 (689.4)
636085	3/8" (M) x 3/8" (F)	Fabric with neoprene	10,000 (689.4)
635107	3/8" (M) x 1/2" (F)	Fabric with neoprene	2,000 (137.8)
635117	1/2" (M) x 1/2" (F)	Fabric with neoprene	2,000 (137.8)
635108	3/4" (M) x 3/4" (F)	Fabric with neoprene	1,000 (68.9)
Z 360° SWIVEL			
636077	1/8" (M) x 1/8" (F)	Fabric with neoprene	10,000 (689.4)
636083	1/8" (F) x 3/8" (F)	Fabric with neoprene	10,000 (689.4)
636084	1/8" (F) x 1/4" (F)	Fabric with neoprene	10,000 (689.4)
636086-B	1/4" (F) x 1/4" (M)	Fabric with neoprene	6,700 (461.8)
636087-B	1/4" (F) x 1/4" (M)	Fabric with neoprene Includes 67176-5 edge-type filter element	6,700 (461.8)
636088	3/8" (M) x 3/8" (F)	Fabric with neoprene	10,000 (689.4)
635106	1/2" (F) x 3/8" (M)	Fabric with neoprene	10,000 (689.4)

Swivels are used to give mobility and flexibility for material hoses and dispensing guns. Select the proper working pressure and check the compatibility of the seals with the material being pumped.



636075



636077

Low-Profile Dispensing Valves

Spray valves for the atomization of low-viscosity fluids

These compact, air-operated, automatic spray valves provide air-atomized application of low-viscosity fluids. They are designed to be used with either supply pumps or pressure tanks. Several unique design features seal the material from outside air and moisture and prevent premature curing of material, which allows for either continuous or intermittent use and reduces the need for daily cleanup.

Compact design provides mounting versatility

The narrow dimensions, block shape, and hose placement allow installation in narrow, recessed areas. Multiple valves can be grouped together in an area normally occupied by a single conventional spray valve.

Spray Patterns

Unique spray patterns matched to application requirements

To meet the needs of your individual application, both flat and round spray patterns are available. For wide surface coverage with minimum film thickness, flat spray models are available in both 90 degree and 45 degree spray patterns. For a more focused pattern with a thicker film build or a conical substrate, the round spray models are the appropriate choice.

Extrusion valves for precise applications of bead patterns

For applications that require a precise bead of material rather than a sprayed coating, several extrusion valves are available. Like the spray valves, separate air pressure and material flow adjustments provide regulation of emissions for material savings and precise, accurate patterns.

Multiple valves can be grouped together to achieve a multiple-bead pattern.



407442-8



407442-8-4



407444-3



407441-8



407444-3

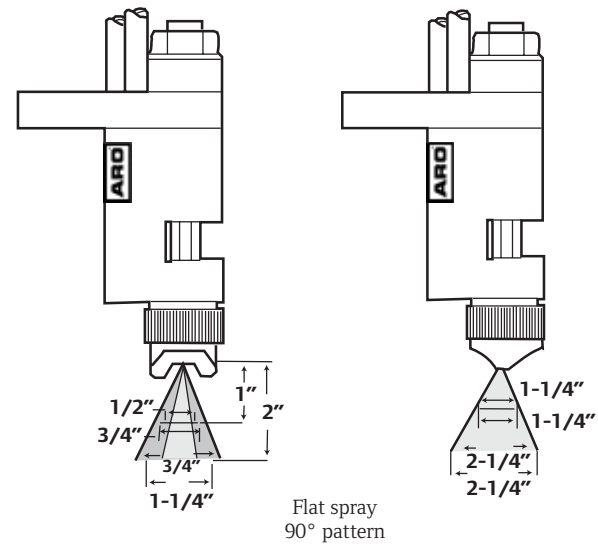

Part Number	Material Pressure psi (bar)	Control Air psi (bar)	Atomizing Air psi (bar)
407442-XX	15 (1.0)	55 (3.8)	20 (1.4)
	30 (2.1)	90 (6.2)	35 (2.4)

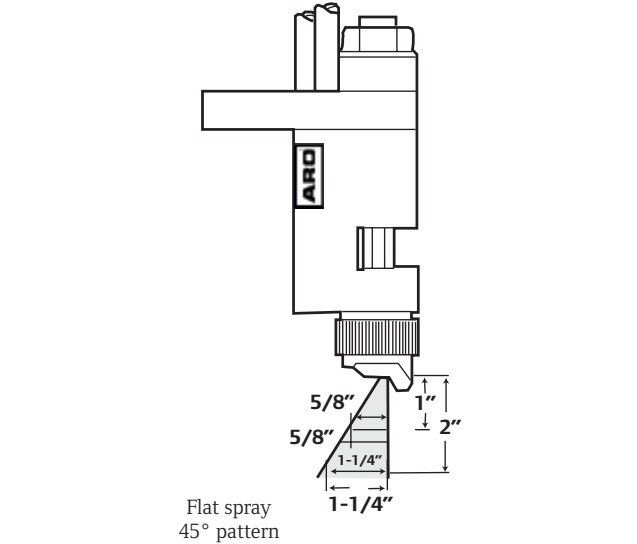

Part Number	Material Pressure psi (bar)	Control Air psi (bar)	Atomizing Air psi (bar)
407442-XX-4	15 (1.0)	55 (3.8)	20 (1.4)
	35 (2.1)	90 (6.2)	35 (2.4)

Part Number	Tip Diameter mm	Fluid Inlet NPT(M)	Atomizing Air Inlet NPT(M)	Control Air Inlet NPT(M)	Minimum Control Air Required psi (bar)	Max Fluid Operating Pressure psi (bar)	Recommended Range Atomizing Air Pressure psi (bar)
FLAT SPRAY — 90° PATTERN							
407442-8	0.8	1/4"	1/4"	1/8"	55 (3.7)	180 (12)	7.5 – 37.5 (0.5 – 2.5)
407442-10	1	1/4"	1/4"	1/8"	55 (3.8)	180 (12)	7.5 – 37.5 (0.5 – 2.5)
407442-15	1.5	1/4"	1/4"	1/8"	55 (3.7)	180 (12)	7.5 – 37.5 (0.5 – 2.5)
FLAT SPRAY — 45° PATTERN							
407442-8-4	0.8	1/4"	1/4"	1/8"	55 (3.7)	180 (12)	7.5 – 37.5 (0.5 – 2.5)
407442-10-4	1	1/4"	1/4"	1/8"	55 (3.7)	180 (12)	7.5 – 37.5 (0.5 – 2.5)
407442-15-4	1.5	1/4"	1/4"	1/8"	55 (3.7)	180 (12)	7.5 – 37.5 (0.5 – 2.5)
ROUND SPRAY — FOCUSED PATTERN							
407443-8	0.08	1/4"	1/4"	1/8"	90 (6)	90 (6)	7.3 – 37.5 (0.5 – 2.5)
407443-12	1.2	1/4"	1/4"	1/8"	90 (6)	90 (6)	7.3 – 37.5 (0.5 – 2.5)
407443-20	2	1/4"	1/4"	1/8"	90 (6)	90 (6)	7.3 – 37.5 (0.5 – 2.5)
ROUND SPRAY — DIFFUSED PATTERN							
407441-8	0.08	1/4"	1/4"	1/8"	55 (3.7)	180 (12)	7.3 – 37.5 (0.5 – 2.5)
407441-10	1	1/4"	1/4"	1/8"	55 (3.7)	180 (12)	7.3 – 37.5 (0.5 – 2.5)
407441-15	1.5	1/4"	1/4"	1/8"	55 (3.7)	180 (12)	7.3 – 37.5 (0.5 – 2.5)
EXTRUSION VALVES							
407444-3	0.3	1/4"	1/4"	1/4"	90 (6)	1,000 (69)	None required
407444-5	0.5	1/4"	1/4"	1/4"	90 (6)	1,000 (69)	None required
407444-7	0.7	1/4"	1/4"	1/4"	90 (6)	1,000 (69)	None required

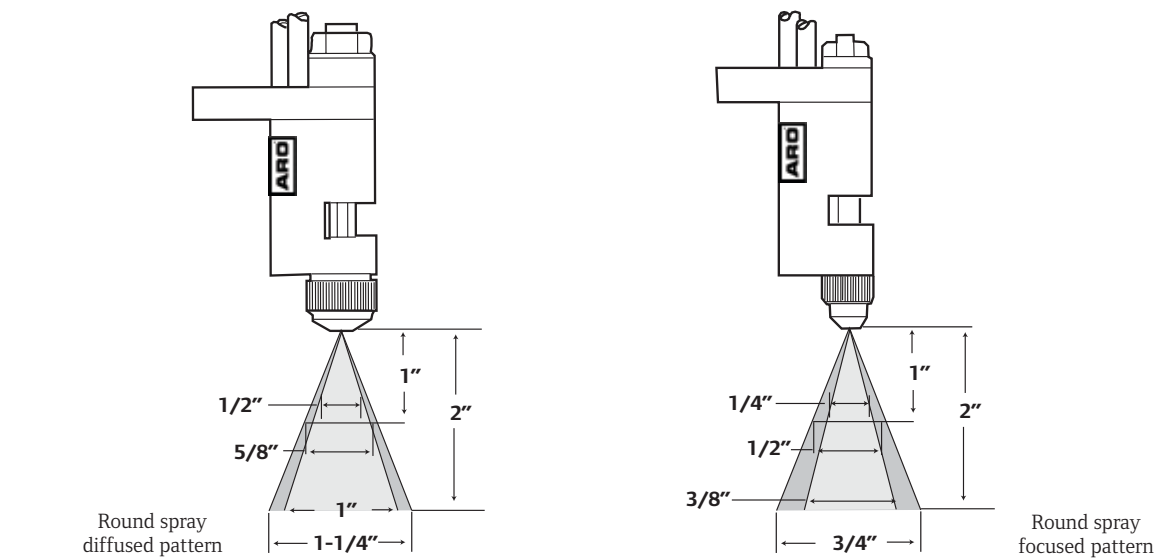

Part Number	Material Pressure psi (bar)	Control Air psi (bar)	Atomizing Air psi (bar)
407441-XX	15 (1.0)	55 (3.8)	20 (1.4)
407446-XX	30 (2.1)	90 (6.2)	35 (2.4)

Part Number	Material Pressure psi (bar)	Control Air psi (bar)	Atomizing Air psi (bar)
407443-XX	15 (1.0)	100 (6.9)	60 (4.1)
	30 (2.1)	100 (6.9)	20 (1.4)

Material Filters

Part Number	Max Fluid Pressure psi (bar)	Filter Mesh	Filter Microns	Filter Inlet size NPT (qty)	Filter Outlet size NPT (qty)
1/4" FLUID INLET — CARBON STEEL CONSTRUCTION					
651412	5,000 (345)	70	200	1/4" F (2) Bottom swivel	1/4" F (3)
651412-8	5,000 (345)	100	149	1/4" F (2)	1/4" F (3)
1/2" FLUID INLET — STAINLESS STEEL CONSTRUCTION (PASSIVATED)					
651422-40	6,000 (414)	40	375	1/2" F (2)	1/2" F (1)
651422-70	6,000 (414)	70	200	1/2" F (2)	1/2" F (1)
651422-100	6,000 (414)	100	149	1/2" F (2)	1/2" F (1)
1/2" FLUID INLET — CARBON STEEL CONSTRUCTION (E-NICKEL PLATED)					
651420-40	6,000 (414)	40	375	1/2" F (2)	1/2" F (1)
651420-70	6,000 (414)	70	200	1/2" F (2)	1/2" F (1)
651420-100	6,000 (414)	100	149	1/2" F (2)	1/2" F (1)
651421-70	6,000 (414)	70	200	1" (2) 1/2" (1)	3/4" F (1)
1" FLUID INLET — CARBON STEEL CONSTRUCTION (E-NICKEL PLATED)					
651418-40-B	6,000 (414)	40	375	1" F (2)	3/8" F (3)
651418-70-B	6,000 (414)	70	200	1" F (2)	3/8" F (3)
651418-100-B	6,000 (414)	100	149	1" F (2)	3/8" F (3)

Part Number	Description
94256	OUTLET REDUCING ADAPTER
Features	• For mounting material filter 1" NPT(M) x 1/2" NPT(M)
Used With	• Integrity 2-ball pumps

Material Filter Screens

Part Number	Screen Mesh	Filter Used With
91192-2	70	651412
91192-3	100	651412
91192-4	200	651412
93944-40	40	651420 651422
93944-70	70	651420 651422
93944-100	100	651420 651422
93945-40	40	651418
93945-70	70	651418
93945-100	100	651418



651412-X

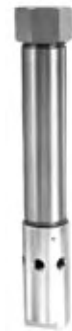

651418-XX-B



651420-XX-B



93944-70

Floor Mounts

Part Number	Description
65138	FLOOR MOUNT
Features	• Accepts fluid line from bulk containers or mixing tanks • 3" NPT(F) inlet; 1/4" NPT(F) vent port with plug
Used With	• 4-1/4" and 6" air motor, 2-ball and extrusion pumps • 8" 40:1 2-ball and 44:1 extrusion pumps • Hydraulic: 0.8:1 and 3.3:1 2-ball; 2:1 and 3.6:1 chop-check pumps • Mounting footprint "A"
65139	FLOOR MOUNT
Features	• Accepts fluid line from bulk containers or mixing tanks • 3" NPT(F) inlet; 1/4" NPT(F) vent port with plug
Used With	• 8", 10", or 12" air motor, 2-ball and extrusion pumps • Hydraulic: 1.2:1 chop-check; 2.4:1 2-ball pumps • Mounting footprint "B"



65139

Bulk/Tote Tank Supply Components

Part Number	Description
628088-7	MATERIAL SUPPLY HOSE
	• Heavy-duty (1" diameter) hose features neoprene construction with a 5,000 psi maximum working pressure • Both ends 1" NPT (M), length 7'
67073	BALL VALVE
	• For use with 628088-7 material supply hose • 4,500 psi maximum working pressure rated
65138, 65139	PUMP FLOOR MOUNT
Features	• Accepts suction line from bulk containers or mixing tanks • 3" NPT(F) inlet; 1/4" NPT(F) vent port with plug
628089-2, 628089-6	MATERIAL HOSE WITH FITTINGS
	• 3" diameter hose has cross-linked polyethylene (internal) and neoprene (external) construction • Hose comes with female cam-lever locking coupler, male adapter, cam-lever locking dust cap, and dust plug • Length of 2" (628089-2) and 6" (628089-6) • Maximum working pressure of 125 psi

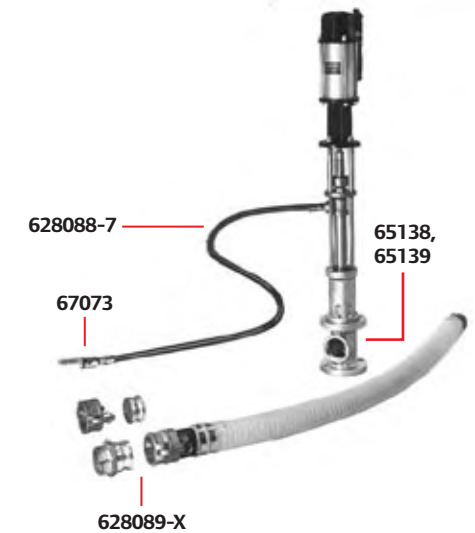

628088-7

67073

65138,
65139

628089-X

Drum Covers

Part Number	Description
651851	DRUM COVER
Features	<ul style="list-style-type: none"> • Accepts 65986 siphon hose and 651100 agitator • Carbon steel
Used With	<ul style="list-style-type: none"> • 2" and 3" air motor wall-mounted stub pumps that use 65986 siphon hose
Container Size	• 5 gallon
66971	DRUM COVER
Features	<ul style="list-style-type: none"> • Stainless steel, accepts 651100 agitator
Used With	<ul style="list-style-type: none"> • 1/2" ports diaphragm pump
Container Size	• 5 gallon
66197	DRUM COVER
Features	<ul style="list-style-type: none"> • Includes hinged access covers, 2" NPT(F) bung opening, and will accept 651104-1 agitator • Carbon steel
Used With	<ul style="list-style-type: none"> • 2", 3" and 4-1/4" 55-gal bung-type pumps
Container Size	• 55 gallon
651852	DRUM COVER
Features	<ul style="list-style-type: none"> • Includes hinged access covers, 2" NPT(F) bung opening, 2" x 34" pipe extension and 60307-1 agitator • Carbon steel
Used With	<ul style="list-style-type: none"> • Accepts 65986-1 siphon hose from any wall-mounted pump; any 55-gallon bung-type pump that can be used with 640067 lift
Container Size	• 55 gallon
651853	DRUM COVER
Features	<ul style="list-style-type: none"> • Stainless steel with 651104-1 agitator, suction tube with 90° elbow, 1" return port, and hinged access door
Used With	<ul style="list-style-type: none"> • Accepts 67140-2 siphon hose and tube from wall-mounted pump
Container Size	• 55 gallon



651851



66197



651852

Agitators

Part Number	Container Size gal	Drum Cover	Air Motor Number	hp (kW)	Motor rpm	Mount	Diameter in (mm)	Length in (mm)	Rod Model	Material
651100	5	651851 drum cover	650252	1/3 (.25)	500 – 1,000	Hub	1/2" (12.7)	12" (305)	92094-4	416 stainless steel
651104-3	5	drum cover	650250	3/4 (.36)	300 – 3,000	Flange	1/2" (12.7)	10.5" (267)	92094-3	316SS stainless steel
60307-1	55	61729, 66197 drum cover	650250	3/4 (.56)	300 – 3,000	Flange	1/2" (12.7)	32" (813)	73120	Carbon steel
651103	55	Drum side mount	650250	3/4 (.56)	300 – 3,000	Flange	1/2" (12.7)	32" (813)	92094-1	316 stainless steel
651104-1	55	66197 drum cover	650250	3/4 (.56)	300 – 3,000	Flange	1/2" (12.7)	32" (813)	92094-1	316SS stainless steel

Propeller Specifications

Part Number	Number of Props	Diameter in (mm)	Prop Number	Material	Prop Direction
651100	1	4" (102)	94783-1	316 stainless steel	CCW
651104-3	1	5" (127)	94783-1	316 stainless steel	CCW
60307-1	2	5" (127)	73121, 73122	316 stainless steel	CCW
651103	2	5" (127)	94783-1	316 stainless steel	CCW
651104-1	2	5" (127)	94783-1	316 stainless steel	CCW



651100



651103



651104-3



651104-1

Wall-Mounts

Part Number	Description
61113	WALL-MOUNT BRACKET
Features	<ul style="list-style-type: none"> • 2" NPT(F) opening to accept bung type pumps • Bracket slips over rim of open head drum or can be wall-mounted
Used With	<ul style="list-style-type: none"> • 612041-X, NM2202A-41-X, NM2202B-41-X, NM2304A-41-X, NM2304B-41-X, 650409-X and 650453-X
66100	WALL-MOUNT BRACKET
Features	<ul style="list-style-type: none"> • With 91395 removable mounting plate
Used With	<ul style="list-style-type: none"> • 4-1/4" air motor 4" stroke pumps
66101	WALL-MOUNT BRACKET
Features	<ul style="list-style-type: none"> • With 91396 removable mounting plate
Used With	<ul style="list-style-type: none"> • 4-1/4" and 6" air motor 2-ball and 4-ball pumps; including Integrity and Stinger models
66542	WALL-MOUNT BRACKET
Features	<ul style="list-style-type: none"> • With 92371 removable mounting plate
Used With	<ul style="list-style-type: none"> • 8", 10" and 12" air motor 2-ball pumps • 8" air motor Stinger 4-ball pumps
76763	WALL-MOUNT
Features	<ul style="list-style-type: none"> • Open front permits easy installation of pump • Can be bolted to wall at back or side of bracket
Used With	<ul style="list-style-type: none"> • All "N" Series and 1/2" diaphragm pumps



61113



66100



76763

Siphon Hoses

Part Number	Description
65986-1	SIPHON HOSE
Features	<ul style="list-style-type: none"> • 55-gallon size; neoprene cover and thiokol tube • Includes 91020-2 pipe extension
Used With	<ul style="list-style-type: none"> • 651852 drum cover or closed drum with 2" bung opening
Hose	<ul style="list-style-type: none"> • 6' length, 3/4" (M) fluid outlet
622702-6	SIPHON HOSE
Features	<ul style="list-style-type: none"> • 1" I.D. hose with stainless steel fittings
Used With	<ul style="list-style-type: none"> • Stainless steel stub pumps
Hose	<ul style="list-style-type: none"> • 6' length, 1" (M) fluid outlet, 1" (M) fluid inlet
622702-10	SIPHON HOSE
Features	<ul style="list-style-type: none"> • 1" I.D. hose with stainless steel fittings
Used With	<ul style="list-style-type: none"> • Stainless steel stub pumps
Hose	<ul style="list-style-type: none"> • 10' length, 1" (M) fluid outlet, 1" (M) fluid inlet
622701-6	SIPHON HOSE
Features	<ul style="list-style-type: none"> • 1" I.D. hose with carbon steel fittings
Used With	<ul style="list-style-type: none"> • Carbon steel stub pumps
Hose	<ul style="list-style-type: none"> • 6' length, 1" (M) fluid outlet, 1" (M) fluid inlet
67140-1	STAINLESS STEEL SIPHON HOSE
Features	<ul style="list-style-type: none"> • For 5-gallon containers; includes 16" wand and 5' of 3/4" I.D. hose
Used With	<ul style="list-style-type: none"> • Wall-mounted Integrity pumps
Hose	<ul style="list-style-type: none"> • 5' length, 3/4" (M) fluid outlet
67140-2	STAINLESS STEEL SIPHON HOSE
Features	<ul style="list-style-type: none"> • For 55-gallon containers; includes 36" wand and 5' of 3/4" I.D. hose
Used With	<ul style="list-style-type: none"> • Wall-mounted Integrity pumps
Hose	<ul style="list-style-type: none"> • 5' length, 3/4" (M) fluid outlet



67140-1



65986

Tubes

Part Number	Description
65109	SIPHON TUBE ASSEMBLY
Features	<ul style="list-style-type: none"> • 55-gallon size carbon steel with 2" bung adapter; hose not included • Suggest 622681-6 hose for 3/4" inlet or 66701-6 hose for 1" inlet
Used With	<ul style="list-style-type: none"> • Wall-mounted stub pumps when fluid viscosity requires a foot valve for priming or with drum cover that has a 2" NPT(F) bung adapter
Fluid Outlet	<ul style="list-style-type: none"> • 3/4" NPT(F) or 1" NPT(F)
66568	SIPHON TUBE ASSEMBLY WITH FILTER AND CHECK VALVE ASSEMBLY
Features	<ul style="list-style-type: none"> • 316 stainless steel with 2" NPT bung adapter and 66480 filter and check valve assembly; hose not included • Suggest 622702-6 hose
Used With	<ul style="list-style-type: none"> • Wall-mounted stub pumps when fluid is corrosive and viscosity requires a foot valve for positive priming
Fluid Outlet	<ul style="list-style-type: none"> • 1" NPT(F)
66717	PIPE EXTENSION
Features	<ul style="list-style-type: none"> • Constructed of PVC for 650408 and NM2304B-X pumps
Used With	<ul style="list-style-type: none"> • 55-gallon containers
91020-1	PIPE EXTENSION
Features	<ul style="list-style-type: none"> • 1/2" I.D. galvanized suction tube
Used With	<ul style="list-style-type: none"> • 5-gallon containers
91020-2	PIPE EXTENSION
Features	<ul style="list-style-type: none"> • 1/2" I.D. galvanized suction tube
Used With	<ul style="list-style-type: none"> • 55-gallon containers



65109

66568

91020-1

Inlet Accessories/Adapters

Part Number	Description
651830	SCREEN ASSEMBLY
Features	<ul style="list-style-type: none"> • Adapts to 91020-1 or 91020-2 pipe extension keeps foreign matter from entering lower pump end
66480	FILTER AND CHECK VALVE ASSEMBLY
Features	<ul style="list-style-type: none"> • 316 stainless steel assembly has 1" NPT(F) connections and 40 mesh screen • 4-3/4" long x 2-1/8" diameter • Used with suction tubes when fluid is corrosive and viscosity requires a foot valve for positive priming
94254	INLET ADAPTER
Features	<ul style="list-style-type: none"> • 90° 1" NPT(M) x 3/4" (F) used to adapt suction hose to 67139 cart
Used With	<ul style="list-style-type: none"> • Integrity pumps
94256	OUTLET REDUCING ADAPTER
Features	<ul style="list-style-type: none"> • For mounting material filter 1" NPT(M) x 1/2" NPT(M)
Used With	<ul style="list-style-type: none"> • Integrity 2-ball pumps



66480



94254



94256

Floor Mounts/Portable Carts

Part Number	Description
67187-1	MOUNTING POST
Features	• Floor stand mounting post with 4-1/4", 6", and 8" air motors
Used With	• 4-1/4", 6" and 8" Stinger 4-ball pumps
66554-2	PORTABLE CART
Features	• 24" to 30" wheel spacing adjustment; has 16" tires
Used With	• 8", 10" and 12" air motor 2-ball pumps • 8" air motor Integrity 2-ball pumps
67139	PORTABLE CART
Features	• Will clear 28" openings • Unique chair design distributes pump weight and makes moving easy • 12" (305 mm) pneumatic tires also enhance smooth transport
Used With	• 4-1/4" and 6" Integrity 2-ball pumps



67187-1

66554-2



67139



635040

Over-Run Controls

Part Number	Description
635040	ARO-STOP® VALVE
Features	• Shuts off air to the pump when material container is empty or line is broken • Quick set and reset feature
Used With	• 2" and N-Series air motor pumps
Air Inlet/Outlet	• 1/4" NPT(F) inlet/1/4" NPT(M) outlet
Pressure Range	• 20 – 175 psi (1.4 – 12 bar)
Flow	• 21 cfm @ 100 psi
23644-400	ARO-STOP VALVE
Features	• Shuts off air to the pump when material container is empty or line is broken • Quick set and reset feature
Used With	• 4-1/4" and 6" air motor pumps
Air Inlet/Outlet	• 1/2" NPT(F) inlet/1/2" NPT(M) outlet
Pressure Range	• 20 – 175 psi (1.4 – 12 bar)
Flow	• 80 cfm @ 100 psi
635043	ARO-STOP VALVE
Features	• Shuts off air to the pump when material container is empty or line is broken • Quick set and reset feature
Used With	• 8", 10", and 12" air motor pumps
Air Inlet/Outlet	• 3/4" NPT(F) inlet/3/4" NPT(M) outlet
Pressure Range	• 20 – 175 psi (1.4 – 12 bar)
Flow	• 135 cfm @ 100 psi

Air Motor Muffler

Part Number	Description
91790	AIR MOTOR MUFFLER
Features	• Reduces air exhaust noise level to acceptable OSHA standards
Used With	• 4-1/4" and 6" air motor pumps
Air Inlet	• 1-1/4" NPT(M)
Size	• 3-1/2" x 11-3/16" psi (89 x 284 bar)
92460	AIR MOTOR MUFFLER
Features	• Reduces air exhaust noise level to acceptable OSHA standards
Used With	• 8" air motor pumps
Air Inlet	• 1-1/4" NPT(M)
Size	• 5-5/8" x 15-3/8" psi (143 x 391 bar)
66718	AIR MOTOR MUFFLER
Features	• Reduces air exhaust noise level to acceptable OSHA standards
Used With	• 10" and 12" air motor pumps
Air Inlet	• Bolted-on
Size	• 9" x 20" psi (229 x 508 bar)



91790

92460



66718

Wet Sol "Plus"

Part Number	Description
66333-B	WET SOL — 1-QUART CONTAINER
Features	• Designed to prolong packing life by keeping the piston rod and packings wetted • Reduces the possibility of material hardening on the piston rod • Tricresyl phosphate
Used With	• All pumps with wet cups
66334-B	WET SOL — 1-GAL CONTAINER
Features	• Tricresyl phosphate



66334-B

Filters/Regulators/Lubricators

Part Number	Description
MODULE/AIR 1000™	
C28121-800	FILTER/REGULATOR/LUBRICATOR
Features	Drop/fog-type lubrication, 20 micron filter, polycarbonate bowl with guard
Used With	2" and 3" air motor pumps
Port Size	1/4" NPT(F)
Pressure Range/Flow	5 – 125 psi (0.3 – 8.6 bar)/13 scfm (6 dm ³ /s)
P29122-600	
P29122-600	FILTER/REGULATOR
Features	Drop/fog-type lubrication, 20 micron filter, polycarbonate bowl with guard
Used With	2" and N Series air motors
Port Size	1/4" NPT(F)
Pressure Range/Flow	5 – 125 psi (0.3 – 8.5 bar)/12 scfm (6 dm ³ /s)
MODULE/AIR 2000™	
C28241-810	FILTER/REGULATOR/LUBRICATOR
Features	Drop/fog-type lubrication, 40 micron filter, metal bowls with sight glass
Used With	4-1/4" and 6" air motor pumps
Port Size	1/2" NPT(F)
Pressure Range/Flow	5 – 125 psi (0.3 – 8.6 bar)/110 scfm (52 dm ³ /s)
P29241-610	
P29241-610	FILTER/REGULATOR
Features	Drop/fog-type lubrication, 40 micron filter, metal bowls with sight glass
Used With	4-1/4" and 6" air motors
Port Size	1/2" NPT(F)
Pressure Range/Flow	6 – 125 psi (0.3 – 8.5 bar)/140 scfm (66 dm ³ /s)
HEAVY DUTY	
28353	FILTER/REGULATOR/LUBRICATOR
Features	Drop/fog-type lubrication, 40 micron filter, polycarbonate bowl with guard
Used With	8", 10", and 12" air motor pumps
Port Size	3/4" NPT(F)
Pressure Range/Flow	5 – 125 psi (0.3 – 8.6 bar)/75 scfm (35 dm ³ /s)



C28121-800



P29122-600



C28241-810



P29241-610



28353

Air Line Lubricant

Part Number	Description
62274	1-QUART BOTTLE
Features	A high-quality extreme pressure gear oil, non-detergent, rust or oxidation inhibited, with a viscosity of 700 – 1,000 S.U.S. at 100° F

Manifold Assemblies

Part Number	Description	Port Size in (cm)	Max Flow
MANIFOLD ASSEMBLIES			
Features	Assemblies include heavy-duty series filter/regulator/lubricator trio, hose which attaches to pump air motor and mounting brackets that attach to ram, cart, or wall-mount application.		
65940			
Used With	4-1/4" and 6" air motors for pumps on 651616-XX and 651612-XX rams	1/2" (1.27)	75 SCFM (31 dm ³ /s)
651730			
Used With	8" air motors for pumps on 651616-XX and 651612-XX rams	3/4" (1.9)	75 SCFM (35 dm ³ /s)
651728			
Used With	8", 10" and 12" air motors for cart and wall mounted pump	3/4" (1.9)	75 SCFM (35 dm ³ /s)
651729			
Used With	10" and 12" air motors for pumps on 651616-XX and 651612-XX rams	3/4" (1.9)	75 SCFM (35 dm ³ /s)



65940

Solenoid Actuated Control Valves

2-Way Solenoid/Pilot Acting Valves

Part Number	Port Size	Cv	Voltage	Pump Air Motor							
				2"	3"	4-1/4"	6"	8"	10"	12"	
TB03EB-024-D	3/8"	4.5	24 DC	x	x						
TB03EB-120-A	3/8"	4.5	120 AC	x	x						
TB04EB-024-D	1/2"	4.5	24 DC			x	x				
TB04EB-120-A	1/2"	4.5	120 AC			x	x				
TB06EB-024-D	3/4"	12	24 DC					x	x	x	
TB06EB-120-A	3/4"	12	120 AC					x	x	x	

Note: Connectors are listed on the following page.

- Normally closed
- Brass body
- Stainless steel stem
- Spring return
- Connector options include: CSN-30 or CHW-30



TB06HB-120-A

2-Way Direct Acting Solenoid Valves

Part Number	Port Size	Cv	Voltage	Pump Air Motor							
				2"	3"	4-1/4"	6"	8"	10"	12"	
TB022B-024-D	1/4"	0.18	24 DC	x	x						
TB022B-120-A	1/4"	0.18	120 AC	x	x						
TB035B-024-D	3/8"	4	24 DC			x	x				
TB035B-120-A	3/8"	4	120 AC			x	x				
TB045B-024-D	1/2"	4	24 DC			x	x				
TB045B-120-A	1/2"	4	120 AC			x	x				
TB066B-024-D	3/4"	8.6	24 DC					x	x	x	
TB066B-120-A	3/4"	8.6	120 AC					x	x	x	

Note: Connectors are listed on the following page.

- Normally closed
- Brass body
- Stainless steel stem
- Spring return
- Connector options include: CSN-30 or CHW-30, exception 1/4" valve which uses CSN or CHW



TB035B-024-D

3-Way Solenoid Actuated Valves

Part Number	Port Size	Cv	Voltage	Pump Air Motor							
				2"	3"	4-1/4"	6"	8"	10"	12"	
CAT66P-024-D	1/4"	0.2	24 DC	x							
CAT66P-120-A	1/4"	0.2	120 AC	x							
MQ3728-024-D	1/4"	1.5	24 DC		x						
MQ3728-120-A	1/4"	1.5	120 AC		x						
H253SS-024-D	3/8"	2.2	24 DC			x	x				
H253SS-120-A	3/8"	2.2	120 AC			x	x				
H254SS-024-D	1/2"	2.4	24 DC			x	x				
H254SS-120-A	1/2"	2.4	120 AC			x	x				
MQ3729-024-D	3/4"	7.5	24 DC					x	x	x	
MQ3729-120-A	3/4"	7.5	120 AC					x	x	x	

Note: Connectors are listed on the following page.

- Normally closed
- Aluminum body
- Spring return
- Connector options include: CSN-30 or CHW-30 for CAT66-P; CSN or CHW for all others



CAT66P

MQ3728



H253SS

MQ3729

Air Control Needle Valves

Part Number	Port Size	Cv	Pump Air Motor							
			2"	3"	4-1/4"	6"	8"	10"	12"	
104104-N02	1/4"	.48	x	x						
104104-NS2	1/4"	.48	x	x						
Features Stainless Steel Needle and Inserts										
104104-N04	1/2"	1.3			x	x				
104104-N06	3/4"	1.9					x	x	x	



104104-N02

- Composite body
- Can be panel-mounted
- Infinite control settings
- Corrosion-resistant stainless steel insert and stem

Lock-Out Valves/Hasp

Part Number	Port Size	Pump Air Motor								
		2"	3"	4-1/4"	6"	8"	10"	12"		
104253-2	1/4"	x								
Safety Lock-Out for Module-Air 1000										
104174-2	1/4"	x	x							
Safety Lock-Out for Module-Air 2000										
104174-4	1/2"			x	x					
Safety Lock-Out for Module-Air 2000										
100085 (Hasp)		x	x	x	x	x	x	x	x	



104174

- Meets OSHA lock-out/tag-out regulations
- Installs upstream of air filter/regulator unit

Connectors

Part Number	Description
CSN	Strain relief connector for 3-way valves
CSN-30	Strain relief connector for 2-way valves and CAT66P-XXX-X valves
CHW	Molded cable connector for 3-way valves, 36" molded leads
CHW-30	Molded cable connector for 2-way valves and CAT66P-XXX-X, 36" molded leads



CSN-30



CHW-30

Coils

Part Number	Description
116218-39	22 mm, 24 volts DC coil
116218-33	22 mm, 120 volts AC coil
119378-39	30 mm, 24 volts DC coil
119378-33	30 mm, 120 volts AC coil

Fluid Hoses

Hose Material	Description
BUNA N	
Features	Buna N is highly resistant to petroleum-based oils and many cleaners; hoses incorporating a Buna N tube make excellent air hoses when lubrication is required in the air line
Recommended For	Ammonia solutions, petroleum oils and fluids, water, silicone greases and oils, di-ester base lubricants, ethylene glycol base fluids, abrasive material, corn oil, ethylene alcohol, soap solution
Not Recommended For	Acetate solvents, ketones (MEK, acetone), strong acids, ozone, automatic brake fluid, benzene, carbon disulfide, ethylene chloride
GRS	
Features	GRS (Government Rubber Styrene) has superior wear characteristics; high tensile properties, good abrasion, and moisture resistance makes a fine air hose
Recommended For	Automatic brake fluid, alcohols, water Use as an air hose
Not Recommended For	Ozone, petroleum oil, many chemicals, abrasive material
POLYSULFIDE (THIOL)	
Features	Highly resistant to most paint solvents; suitable for use as a flexible supply line carrying paint, latex materials, gasoline, and oil
Recommended For	4-1/4" air motor and 6" air motor; 2-ball and 4-ball pumps (including Integrity/Stinger pumps)
Not Recommended For	Automatic brake fluid, alcohols, non-oxidizing acids, oils, ketones (MEK, acetone)
NEOPRENE	
Features	Good resistance to ozone, sunlight, and oxidation; performs well in contact with oils, is heat and flame-resistant, and has good tensile strength and resilience
Recommended For	Refrigerants (freons), petroleum oil, mild acids, silicate ester lubricants, abrasive material, calcium chloride
Not Recommended For	Phosphate ester fluids, ketones (MEK, acetone), benzene
NYLON	
Features	Nylon is tough and retains its shape at elevated temperatures; is highly resistant to abrasion and to the effects of most chemicals; unaffected by oil, enamel, or lacquer solvents when used as a fluid supply hose
Recommended For	Lubricating oils and grease, aliphatic and aromatic hydro-carbons, common esters, ketones, ethers, alkalis, abrasive material, benzene, butyl alcohol, carbon tetrachloride
Not Recommended For	Strong acids, RTV, creosote, oxidizing agents

For further hose material compatibility, consult the Ingersoll Rand / ARO Piston Pumps Material Compatibility Guide, Form Number 8677-P.

The material characteristic chart indicates what type of hose material is recommended for specific fluids. The following charts list hoses in order of use, size, tube, cover materials, and maximum working pressure. In selecting the proper hose, be sure the hose material and fluid is compatible and that the maximum working pressure will not be exceeded in the application.

Standard length hoses, which are a stock item ready for shipment, are listed in the "standard lengths" column of the selection chart on the following page.

Low-Pressure Air and Fluid Hoses

Part Number	Fitting Thread Size	Hose Materials Tube	Cover	Lengths ft (m)	psi (bar)
1/2" I.D., 27/32" O.D., 1 FABRIC BRAID					
621501-2	1/2" NPTM x 1/2" NPTM	GRS	GRS	2' (.6)	125 (9)
621501-3	1/2" NPTM x 1/2" NPTM	GRS	GRS	3' (.9)	125 (9)
621501-5	1/2" NPTM x 1/2" NPTM	GRS	GRS	5' (1.5)	125 (9)
1/4" I.D., 5/8" O.D., 2 FABRIC BRAID					
622201-3	1/4" NPTM x 1/4" NPTM	Buna N	Neoprene	3' (.9)	250 (17)
622201-5	1/4" NPTM x 1/4" NPTM	Buna N	Neoprene	5' (1.5)	250 (17)
622201-25	1/4" NPTM x 1/4" NPTM	Buna N	Neoprene	25' (7.6)	250 (17)
622204-5	1/4" NPTM x 1/4" NPTSM (FSN)	Buna N	Neoprene	5' (1.5)	250 (17)
622204-25	1/4" NPTM x 1/4" NPTSM (FSN)	Buna N	Neoprene	25' (7.6)	250 (17)
3/4" I.D., 1-3/16" O.D., 2 FABRIC BRAID					
622651-1-F	3/4" NPTM x 3/4" NPTM	Neoprene	Neoprene	1.5' (.4)	600 (41)



Low-Pressure Fluid Hoses

Part Number	Fitting Thread Size	Hose Materials Tube	Cover	Lengths ft (m)	psi (bar)
1/2" I.D., 11/16" O.D., 2 FABRIC WIRE BRAID					
622581-6	1/2" NPTM x 1/2" NPTM	Thiokol	Neoprene	6' (1.8)	200 (14)
3/4" I.D., 1-1/4" O.D., 2 FABRIC BRAID					
622681-6	3/4" NPTM x 3/4" NPTM	Thiokol	Neoprene	6' (1.8)	200 (14)

Medium-Pressure Fluid Hoses

Part Number	Fitting Thread Size	Hose Materials Tube	Cover	Lengths ft (m)	psi (bar)
1/4" I.D., 1/2" O.D., CONDUCTIVE POLYMER					
628042-25	1/4" NPSM(FSN) x 1/4" NPSM(FSN)	Nylon	Nylon	25' (7.6)	3000 (207)

RTV/Moisture Lok™ Hoses

Part Number	Fitting Thread Size	Hose Materials Tube	Cover	Lengths ft (m)	psi (bar)
3/8" I.D., 11/16" O.D., POLYESTER BRAID					
628081-10	3/8" NPTM x 3/8" NPTM	Polymer	Polyurethane	10' (3.0)	2250 (190)
628081-15	3/8" NPTM x 3/8" NPTM	Polymer	Polyurethane	15' (4.5)	2250 (190)
628081-25	3/8" NPTM x 3/8" NPTM	Polymer	Polyurethane	25' (7.6)	2250 (190)
1/2" I.D., 13/16" O.D., POLYESTER BRAID					
628084-5	1/2" NPTM x 1/2" NPTM	Polymer	Polyurethane	5' (1.5)	2000 (138)
628084-10	1/2" NPTM x 1/2" NPTM	Polymer	Polyurethane	10' (3.0)	2000 (138)
628084-15	1/2" NPTM x 1/2" NPTM	Polymer	Polyurethane	15' (4.5)	2000 (138)
628084-25	1/2" NPTM x 1/2" NPTM	Polymer	Polyurethane	25' (7.6)	2000 (138)

Dispense Equipment

Ingersoll Rand Dispense Equipment is for applications requiring accurate dispensing of highly viscous materials. Ejection Valves repetitively deliver the same quantity of fluid. Fluid Regulators have the flow and pressure ratings for mastic and sealant applications.

Automatic Dispensing Valves

Metered ejection valves are used in applications requiring repetitive delivery of a set quantity of fluid. An adjusting screw on the valve allows the operator to adjust the amount of fluid delivered. Requires a hose or extrusion tip for installation (see chart below). A pneumatic directional valve is required to shift the ejection valve.

Model Number	Description	Material Output cu in (cm ³)	Max Inlet Pressure psi (bar)	Material Inlet	Material Outlet	Air Inlet Port	Repair Kit
102-002	Ejection valve	0.25 (4)	2000 (137)	1/4"	1/4"	1/8"	102-002RK
102-004DC	Ejection valve	0.25 (4)	2000 (137)	1/4"	Determined by nozzle	1/8"	102-004RK
102-006DCA	Drawback ejection valve	0 – 0.75 (12)	2800 (193)	1/4"	Determined by nozzle	1/8"	102-006RK
102-008	Drawback ejection valve	0 – 0.75 (12)	2000 (137)	1/4"	1/4"	1/8"	102-008RK
102-010	Ejection valve	0 – 0.061 (1)	1200 (82)	1/4"	1/4"	1/8"	102-010RK
102-012	Ejection valve	0 – 2.0 (32.7)	3000 (206)	3/8"	3/8"	3/8"	102-012RK
102-019B	Ejection valve	0 – 0.245 (4)	2000 (137)	1/4"	1/4"	1/8"	102-019BRK
102-020B	Ejection valve	0 – 0.245 (4)	2000 (137)	1/4"	1/4"	1/8"	102-020BRK
102-030	Ejection valve, heavy-duty	0 – 0.75 (12)	2000 (137)	1/4"	Determined by nozzle	1/8"	120-453RK
103-005	Bearing greaser	0 – 5.5 (90)	3000 (206)	3/8"	3/8"	3/8"	103-005RK

Nozzles

Nozzles are used with metered ejection valves. In extruding applications, the tip produces a larger bead than in streaming applications.

Model	Description	Orifice
EXTRUDING TIP		
400-723	Extruding tip	0.093
400-724	Extruding tip	0.125
400-725	Extruding tip	0.187
400-726	Extruding tip	0.250



Fluid Regulators

Regulators are used to maintain fluid pressure at a desired level and smooth out fluid delivery. These fluid regulators give the end-user greater control when dispensing high viscosity mastics and sealants.

Model	Flow Capability	Orifice Size	Max. Inlet Pressure	Regulated Pressure Range	Inlet Port Size	Outlet Port Size
DOWNSTREAM FLUID REGULATORS CAPABLE OF HANDLING VISCOUS MASTICS AND SEALANTS						
300-911AS	Low	0.281	5000 (340)	300 – 5000	3/4"	(2) 3/4"
300-911BS	Medium	0.312	5000 (340)	300 – 5000	3/4"	(2) 3/4"
300-911CS	High	0.375	5000 (340)	300 – 5000	3/4"	(2) 3/4"
300A911BS	Medium	0.312 (abrasive resistant)	5000 (340)	300 – 5000	3/4"	(2) 3/4"
300-911ASJ (water jacketed)	Low	0.281	5000 (340)	300 – 5000	3/4"	(2) 3/4"
300-911BSJ (water jacketed)	Medium	0.312	5000 (340)	300 – 5000	3/4"	(2) 3/4"
300-911CSJ (water jacketed)	High	0.375	5000 (340)	300 – 5000	3/4"	(2) 3/4"
300A911BSJ (water jacketed)	Medium	0.312 (abrasive resistant)	5000 (340)	300 – 5000	3/4"	(2) 3/4"



Valve and Filter Components

These improve the operation and safety of a dispense system. Ball valves can be used to isolate a piece of equipment. Filters eliminate contaminants that could clog downstream equipment.

Model	Type	Description	Pressure Rating
BALL VALVES			
364-538	Ball valve 3/8" NPT	Locking	5000 psi
360-638	Ball valve 1/2" NPT	Locking	5000 psi
360-628	Ball valve 3/4" NPT	Locking with metal seats	5000 psi
360-639	Ball valve 1" NPT	Locking with metal seats	5000 psi
360-606	Ball valve 1-1/4" NPT	Locking with metal seats	5000 psi
360-629DM	Ball valve 2" NPT	Locking	5000 psi
MATERIAL FILTERS			
361T81F03	Material filter 3/4" NPT body	30 mesh element	5000 psi
361T81F04	Material filter 3/4" NPT body	40 mesh element	5000 psi
361T81F06	Material filter 3/4" NPT body	60 mesh element	5000 psi
361T53F03	Material filter 1-1/4" NPT body	30 mesh element	5000 psi
361T53F04	Material filter 1-1/4" NPT body	40 mesh element	5000 psi
361T53F06	Material filter 1-1/4" NPT body	60 mesh element	5000 psi
110-907	Filter assembly 1-1/4" NPT with ball valve and mounting bracket	Mesh to specify 30, 40 or 60	5000 psi
DISPENSE VALVES			
105B038A	Dispense valve 3/4 - 16 nozzle	3/8" NPT or pilot port	4000 psi
105B038C	Dispense valve 7/8 - 14 nozzle	3/8" NPT or pilot port	4000 psi
105B038D	Dispense valve 7/8 - 14 alignment slotted nozzle	3/8" NPT or pilot port	4000 psi

Angled Adapters

When needed, angled adapters provide the dispense valve a better fit to the application. Available in 30 degree, 45 degree, 60 degree and 90 degree angles. A slotted adaptor is supplied to attach to ejection valve.

Model	Angle of Adapter	Used With
USED WITH STREAMING AND EXTRUSION TIPS		
403-114-30	30°	105B038D
403-114-45A	45°	105B038D
403-114A	60°	105B038D
403-114-90B	90°	105B038D

Collars

Model	Thread	Used With	Opening
USED TO ATTACH SPRAY TIP AND EXTRUSION TO 105B038A			
400-667	3/4 - 16	Stream & extrusion	0.550"
400-667A	3/4 - 16	Spray	0.494"

Nozzles

Nozzles are used with dispense valves. In streaming applications, the material is forced out of the tip at higher pressure in the form of a small stream. Extrusion nozzles are used with dispense valves, ejection valves, and manual flow guns. The extruding nozzles produces larger beads than streaming tips.

Model	Description	Orifice
STREAMING TIP		
362-853	Streaming, carbide insert	0.030
362-853A	Streaming, carbide insert	0.035
362-853B	Streaming, carbide insert	0.040
362-853C	Streaming, carbide insert	0.045
362-853D	Streaming, carbide insert	0.050
362-853E	Streaming, carbide insert	0.060
362-853H	Streaming, carbide insert	0.026
362-853L	Streaming, carbide insert	0.075
364-224	Streaming tip	0.187
403-800-115	Streaming tip	0.115
EXTRUDING TIP		
400-723	Extruding tip	0.093
400-724	Extruding tip	0.125
400-725	Extruding tip	0.187
400-726	Extruding tip	0.250

Manual Flow Guns

Used to manually apply a bead of material.

Model	Description	Inlet Port Size
FOR MANUAL DISPENSING OF VISCOUS SEALANTS AND MASTICS		
300-301	Pistol grip flow valve	3/8" NPT
ERGONOMIC HANDLE DESIGN EASES OPERATION AND IMPROVES PRODUCTIVITY		
300-963	Pistol grip flow valve	3/8" NPS



Swivels

Swivels ease operation of a manual flow gun or automated machinery. They give the operator greater mobility and flexibility.

Model	Description	Inlet Port Size	Pressure Rating
SPECIAL SWIVELS FOR 300-936 MANUAL DISPENSE GUNS			
361-936	Straight swivel	Dispense inlet adapter to 3/8" NPSF	NA
362-005	Special union adapter	3/8" NPSM x 3/8" NPTF	NA
HIGH-PRESSURE SWIVELS			
350-632	Straight swivel	3/8" NPTM x 1/2" NPTM	5000 psi
350-635	Straight swivel	1/4" NPTM x 1/4" NPTF	5000 psi
350-636	"Z" type swivel	1/4" NPTM x 1/4" NPTM	5000 psi
350-639	"Z" type swivel	1/4" NPTM x 1/4" NPTM	5000 psi
361-581	Straight (in-line) swivel	3/4" NPTM x 3/4" NPTF	5000 psi
361-581A	Straight (in-line) swivel	3/4" NPTM x 3/4" NPTF	5000 psi
361-589	Straight (in-line) swivel	1" NPTM x 1" NPTF	5000 psi
361-589A	Straight (in-line) swivel	1" NPTM x 1" NPTF	5000 psi

2-Ball Pumps



2-ball pumps are some of the most versatile piston pumps Ingersoll Rand / ARO manufactures, capable of handling applications from simple transfer to the extrusion of viscous materials. ARO produces more than two dozen 2-ball pump models. The result is a variety of pump ratios and pumps that can produce up to 6,000 psi (414 bar) of fluid pressure and up to 18.1 gpm (68.6 L/min) of fluid flow.

These pumps are traditionally used with low-to-medium fluid viscosities. When ram-mounted, some models can handle up to 100,000 cPs.

ARO 2-ball pumps include some of our most technologically advanced models. Pumps like the Integrity™ Series offer Ultra-Coating™ for lower end tubes and plunger rods. This coating combats the abrasive characteristics of fluids like paint and glass-filled sealer.

All ARO pumps are designed to maximize service life and meet your fluid handling needs.

1:1 Ratio, 2" Air Motor, Basic Pump

6 1 2 0 4 X - X

Pump type
1 - 55-gal (205 L)
2 - 275-gal (1,040 L)

Packings
1 - Nitrile
3 - Teflon

Model	A in (mm)	B in (mm)
612041-1	54" (1371.6)	34-5/8" 879.5
612042-1	64-1/4" (1631.9)	44-7/8" (1139.8)

Model	Lower Pump Material	Plunger Material	Stroke in (cm)	Air Inlet	Exhaust Port	Lower Pump Repair Kit	Material Inlet	Material Outlet	Weight lb (kg)
612041-1	Carbon steel	Carbon steel	6" (15.2)	1/4" NPT(F)	3/4" NPT(F)	637081	Immersed	3/4" NPT(F)	13 (5.9)
612041-3	Carbon steel	Carbon steel	6" (15.2)	1/4" NPT(F)	3/4" NPT(F)	637083	Immersed	3/4" NPT(F)	13 (5.9)
612042-1	Carbon steel	Carbon steel	6" (15.2)	1/4" NPT(F)	3/4" NPT(F)	637081	Immersed	3/4" NPT(F)	14 (6.4)

Model	Air Inlet Pressure Range psi (bar)	Fluid Pressure Range psi (bar)	Max Cycles/Minute	Displacement per Cycle cu in (cm ³)	Cycles per gal (L)	Flow @ 75 Cycles gpm (L/min)	Noise Level @ 60 psi dBA
61204X-X	0 - 150 (0 - 10.3)	0 - 150 (0 - 10.3)	75	18.8 (308.0)	12.3 (3.3)	9.0 (34.1)	77.8 db(A)

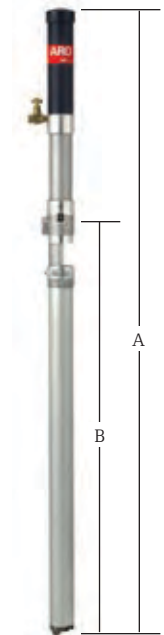

61204X-X

Accessories

Part Number	Description
61204X-X	
C28121-600	Air line F/R/L
61113	Wall mount
61879	Muffler
637084	Air motor repair kit

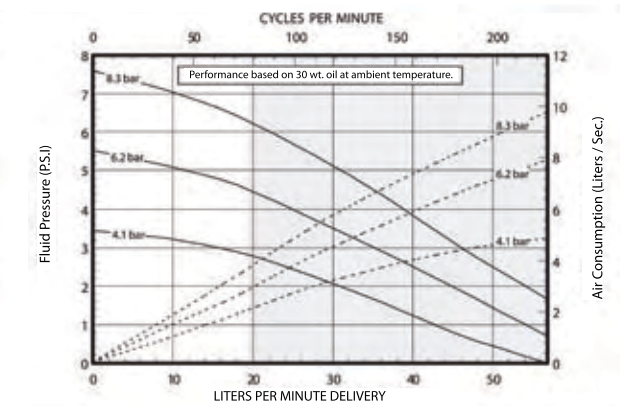
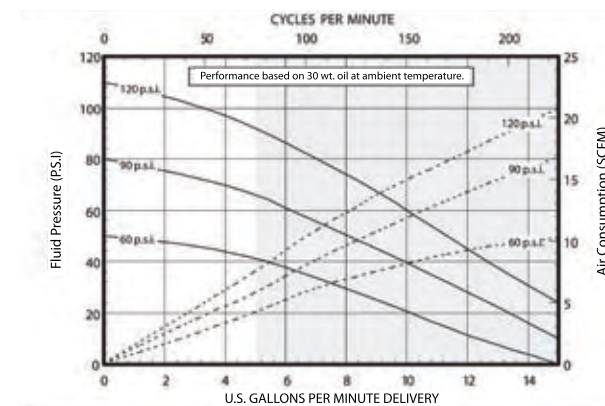

2:1 Ratio, 2" Air Motor, Basic Pump

6 5 0 1 1 0 - X

Packings
C - UHMW-PE
1C - Teflon

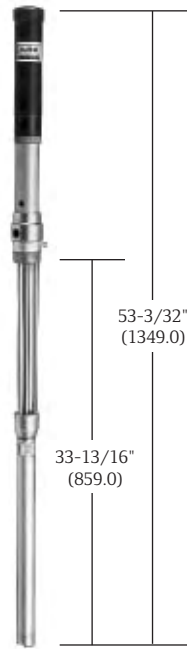

650110-X

Model	Lower Pump Material	Plunger Material	Stroke in (mm)	Air Inlet	Exhaust Port	Lower Pump Repair Kit	Material Inlet	Material Outlet	Weight lb (kg)
650110-C	Carbon steel	Carbon steel	6" (152)	1/4" NPT(F)	1/4" NPT(F)	637028	Immersed	1/2" NPT(F)	12 (5.4)
650110-1C	Carbon steel	Carbon steel	6" (152)	1/4" NPT(F)	1/4" NPT(F)	637029	Immersed	3/4" NPT(F)	12 (5.4)

Model	Air Inlet Pressure Range psi (bar)	Fluid Pressure Range psi (bar)	Max Cycles/Minute	Displacement per Cycle cu in (cm ³)	Cycles per gal (L)	Flow @ 60 Cycles/gpm (L/min)	Noise Level @ 60 psi dBA
650110-C	0 - 150 (0 - 10.3)	0 - 300 (0 - 20.7)	120	8.0 (131.0)	28.9 (7.6)	2.0 (7.5)	81 db(A)
650110-1C	0 - 150 (0 - 10.3)	0 - 300 (0 - 20.7)	120	8.0 (131.0)	28.9 (7.6)	2.0 (7.5)	81 db(A)

Accessories

Part Number	Description
650110-C & 650110-1C	
C28121-600	Air line F/R/L
61113	Wall mount
61879	Muffler
66098	Air motor repair kit

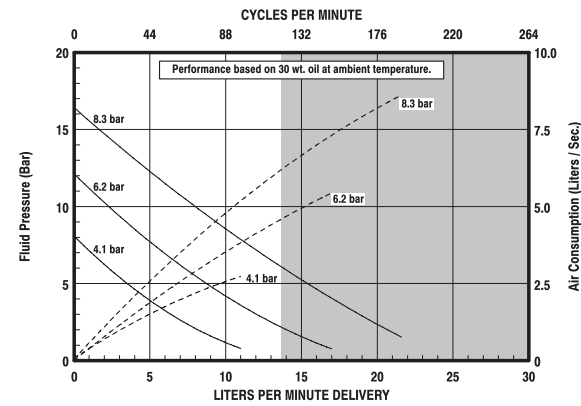
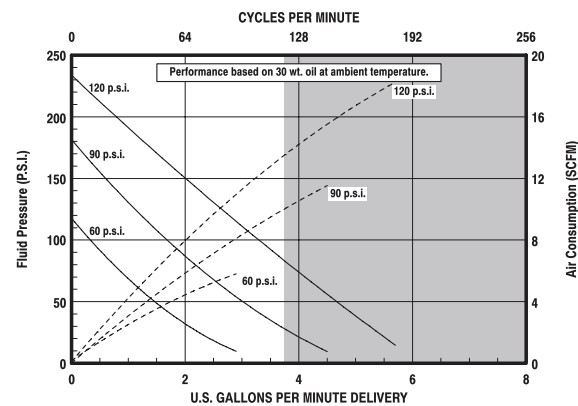

2:1 Ratio, 2" Air Motor, 2-Ball Lower End

N M 2 2 0 2 X - X 1 - X 3 1

Material
A - Carbon steel
B - Stainless steel

Pump types
1 - Stub
4 - 55-gal (205 L)

Packings
7 - Rulon-filled Teflon / Teflon (upper and lower)
C - UHMW-PE / UHMW-PE
J - Polyurethane / UHMW-PE

Model	A in (mm)	B in (mm)
NM2202A-11-X31	34-3/16" (868.0)	20-1/16" (508.8)
NM2202A-41-X31	47-7/8" (1214.8)	33-11/16" (855.6)
NM2202B-11-X31	33-7/8" (859.9)	19-7/8" (503.7)
NM2202B-41-X31	47-3/4" (1211.8)	33-11/16" (855.6)

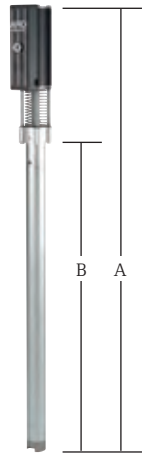

NM2202X-X1-X31

Model	Lower Pump Material	Plunger Material	Air Motor	Stroke in (cm)	Air Inlet NPT(F)	Exhaust Port	Lower Pump Repair Kit	Lower Pump Model	Material Inlet NPT(F)	Material Outlet NPT(F)	Weight lb (kg)
NM2202A-11-X31	Carbon steel	Carbon steel	67316	3" (7.6)	1/4"	—	637378-X31	67319-X31	1-1/2"	3/4"	17.5 (7.9)
NM2202A-41-X31	Carbon steel	Carbon steel	67316	3" (7.6)	1/4"	—	637378-X31	67320-X31	1-1/2"	3/4"	19.6 (8.9)
NM2202B-11-X31	Stainless steel	Stainless steel	67316	3" (7.6)	1/4"	—	637379-X31	67318-X31	1-1/2"	3/4"	17.2 (7.8)
NM2202B-41-X31	Stainless steel	Stainless steel	67316	3" (7.6)	1/4"	—	637379-X31	67317-X31	1-1/2"	3/4"	22.5 (10.2)

Model	Air Inlet Pressure Range psi (bar)	Fluid Pressure Range psi (bar)	Max Cycles/Minute	Displacement per Cycle cu in (cm ³)	Cycles per gal (L)	Flow @ 60 Cycles/gpm (L/min)	Noise Level @ 100 psi dBA
NM2202X-X1-X31	0 - 150 (0 - 10.3)	0 - 351 (0 - 24.2)	120	8.3 (136.0)	27.9 (7.3)	2.15 (8.14)	80

Accessories

Part Number	Description
NM2202X-X1-X31	
66073-1	Air line connection kit
61113	Wall mount
67088-4	Sealed bung assembly
637377	Air motor repair kit

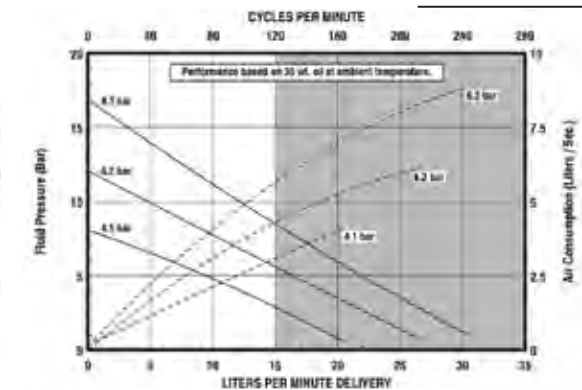
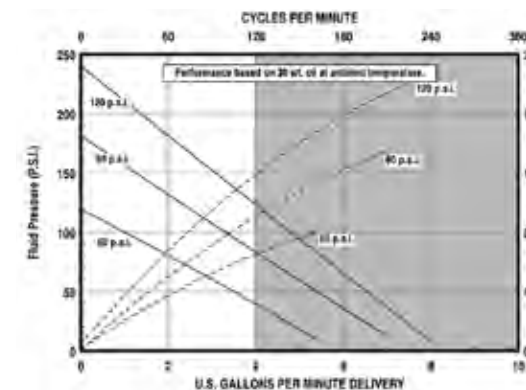

4:1 Ratio, 3" Air Motor, 2-Ball Lower End

N M 2 3 0 4 A - X 1 - X 1 1

- Pump types**
- 1 – Universal (stub), wall-mount
 - 4 – 55-gal (205 L)
 - 8 – Universal (stub) without bung
 - 9 – 55-gal (205 L) without bung
 - A – Stub follower plate
 - B – Universal (stub), with alternate bung

- Packings**
- 3 – Glass-filled Teflon (upper), virgin Teflon (lower)
 - 5 – Glass-filled Teflon / Leather-staggered (upper), virgin Teflon (lower)
 - C – UHMW-PE (upper and lower)

N M 2 3 0 4 B - X 1 - X 1 X

- Pump types**
- 1 – Universal (stub), wall-mount
 - 4 – 55-gal (205 L)

- Plungers**
- 1 – Standard
 - B – Ceramic
- Packings**
- 3 – Virgin Teflon (upper and lower)
 - C – UHMW-PE (upper and lower)
 - W – Viton (upper), virgin Teflon (lower)

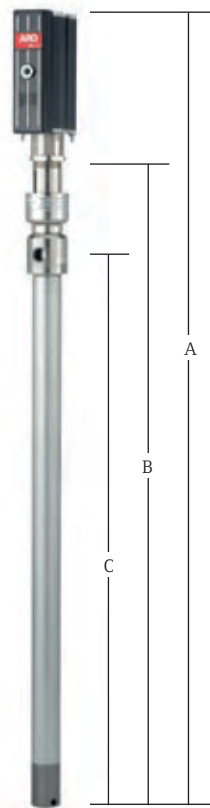

NM2304X-X1-X11

Model	A in (mm)	B in (mm)	C in (mm)
NM2304A-11-X11	30-1/4" (768.5)	11-3/4" (297.7)	13-3/16" (334.2)
NM2304A-41-X11	55-5/8" (1413.0)	37-1/8" (942.2)	38-9/16" (978.7)
NM2304B-11-X11	28-1/8" (714.4)	9-23/32 (246.8)	11-3/32 (281.8)
NM2304B-41-X11	51-21/32 (1312.1)	33-1/4 (844.6)	34-5/8 (879.6)

Available Models	Lower Pump Material	Plunger Material	Air Motor	Stroke in (mm)	Air Inlet	Exhaust Port	Lower Pump Model	Lower Pump Repair Kit	Material Inlet	Material Outlet	Weight lb (kg)
NM2304A-11-311	Carbon steel	Carbon steel	66913	3" (76)	1/4" NPT(F)	N/A	67151-1-311	637176	1-1/4" NPT(F)	3/4" NPT(F)	32 (14.5)
NM2304A-11-511	Carbon steel	Carbon steel	66913	3" (76)	1/4" NPT(F)	N/A	67151-1-511	637176	1-1/4" NPT(F)	3/4" NPT(F)	32 (14.5)
NM2304A-11-C11	Carbon steel	Carbon steel	66913	3" (76)	1/4" NPT(F)	N/A	67151-1-C11	637228	1-1/4" NPT(F)	3/4" NPT(F)	32 (14.5)
NM2304A-41-311	Carbon steel	Carbon steel	66913	3" (76)	1/4" NPT(F)	N/A	67151-4-311	637176	Immersed	3/4" NPT(F)	46 (20.9)
NM2304A-41-511	Carbon steel	Carbon steel	66913	3" (76)	1/4" NPT(F)	N/A	67151-4-511	637176	Immersed	3/4" NPT(F)	46 (20.9)
NM2304A-41-C11	Carbon steel	Carbon steel	66913	3" (76)	1/4" NPT(F)	N/A	67151-4-C11	637228	Immersed	3/4" NPT(F)	46 (20.9)
NM2304A-81-311	Carbon steel	Carbon steel	66913	3" (76)	1/4" NPT(F)	N/A	67151-8-311	637176	1-1/4" NPT(F)	3/4" NPT(F)	31.4 (14.3)
NM2304A-91-311	Carbon steel	Carbon steel	66913	3" (76)	1/4" NPT(F)	N/A	67151-9-311	637176	Immersed	3/4" NPT(F)	45.4 (20.6)
NM2304A-A1-311	Carbon steel	Carbon steel	66913	3" (76)	1/4" NPT(F)	N/A	67151-A-311	637176	Immersed	3/4" NPT(F)	31 (14.1)
NM2304A-B1-311	Carbon steel	Carbon steel	66913	3" (76)	1/4" NPT(F)	N/A	67151-B-311	637176	1-1/4" NPT(F)	3/4" NPT(F)	32 (14.5)

4:1 Ratio, 3" Air Motor, 2-Ball Lower End

Model	Air Inlet Pressure Range psi (bar)	Fluid Pressure Range psi (bar)	Max Cycles/Minute	Displacement per Cycle cu in (cm³)	Cycles per gal (L)	Flow @ 60 Cycles gpm (L/min)	Noise Level @ 100 psi dBA
NM2304A-X1-X11	0 – 150 (0 – 10.3)	0 – 600 (0 – 41.4)	125	8.2 (134.3)	28.2 (7.4)	2.1 (8.0)	85

Available Models	Lower Pump Material	Plunger Material	Air Motor	Stroke in (mm)	Air Inlet	Exhaust Port	Lower Pump Model	Lower Pump Repair Kit	Material Inlet	Material Outlet	Weight lb (kg)
NM2304B-11-311	316 stainless	316 stainless	66913	3" (76)	1/4" NPT(F)	N/A	65108	637010	1-1/4" NPT(F)	3/4" NPT(F)	32 (14.5)
NM2304B-11-31B	316 stainless	316 stainless*	66913	3" (76)	1/4" NPT(F)	N/A	65108-5	637010	1-1/4" NPT(F)	3/4" NPT(F)	32 (14.5)
NM2304B-11-C11	316 stainless	316 stainless	66913	3" (76)	1/4" NPT(F)	N/A	65108-4	637010-4	1-1/4" NPT(F)	3/4" NPT(F)	32 (14.5)
NM2304B-11-C1B	316 stainless	316 stainless*	66913	3" (76)	1/4" NPT(F)	N/A	65108-6	637010-4	1-1/4" NPT(F)	3/4" NPT(F)	32 (14.5)
NM2304B-11-W11	316 stainless	316 stainless	66913	3" (76)	1/4" NPT(F)	N/A	65108-8	637010-6	1-1/4" NPT(F)	3/4" NPT(F)	32 (14.5)
NM2304B-41-311	316 stainless	316 stainless	66913	3" (76)	1/4" NPT(F)	N/A	65106	637010	1-1/4" NPT(F)	3/4" NPT(F)	46 (20.9)
NM2304B-41-C11	316 stainless	316 stainless	66913	3" (76)	1/4" NPT(F)	N/A	65106-4	637010-4	1-1/4" NPT(F)	3/4" NPT(F)	46 (20.9)

*Ceramic coating.

Model	Air Inlet Pressure Range psi (bar)	Fluid Pressure Range psi (bar)	Max Cycles/Minute	Displacement per Cycle cu in (cm³)	Cycles per gal (L)	Flow @ 60 Cycles gpm (L/min)	Noise Level @ 100 psi dBA
NM2304B-X1-X1X	0 – 150 (0 – 10.3)	0 – 600 (0 – 41.4)	120	8.2 (134.3)	28 (7.4)	2.1 (8.0)	85

Accessories

Part Number	Description
NM2304A-X1-X11, NM2304B-X1-X1X	
P29122-600	Piggyback F/R
61113	Wall mount
66333-B	Wet Sol
637316	Air motor repair kit

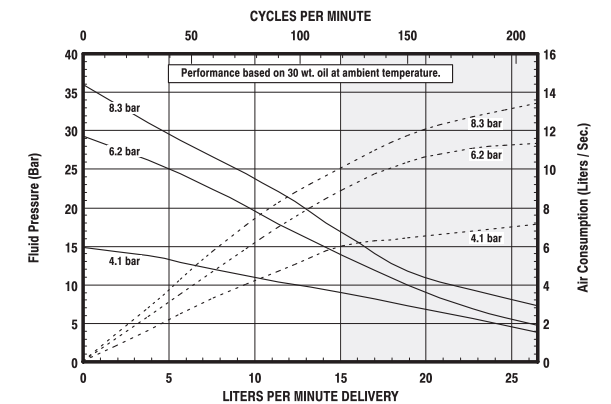
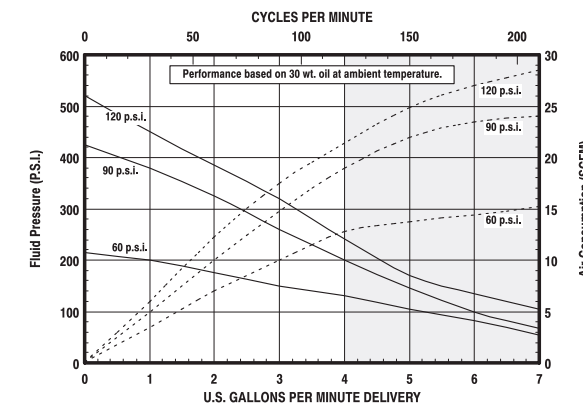

9:1 Ratio, 4-1/4" Air Motor, 2-Ball Lower End

6 5 0 4 0 8 - X - B

6 5 0 4 0 8 - B

Configuration

Teflon packings
Plain rod and tube
Standard motor

Packings

2 – UHMW-PE, plain rod and tube, counter motor
4 – UHMW-PE, plain rod and tube, standard motor
5 – Teflon, ceramic-coated rod and tube, standard motor
6 – UHMW-PE, ceramic-coated rod and tube, standard motor
7 – Viton / UHMW-PE, ceramic-coated rod and tube, standard motor
8 – Viton / UHMW-PE, plain rod and tube, standard motor

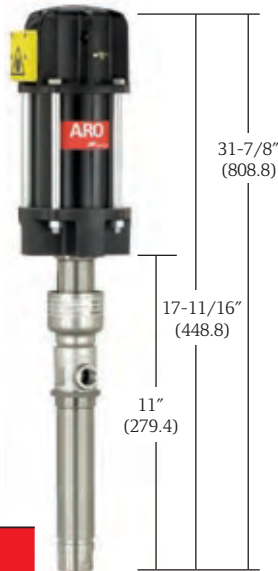

650408-B
650408-X-B

Available Models	Lower Pump Material	Plunger Material	Air Motor	Stroke in (mm)	Air Inlet	Exhaust Port	Lower Pump Model	Lower Pump Repair Kit	Material Inlet	Material Outlet	Weight lb (kg)
650408-B	316 stainless	316 stainless	65444-B	4" (101)	1/2" NPT(F)	1-1/4" NPT(F)	65108-X	637010	1-1/4" NPT(F)	3/4" NPT(F)	35.0 (15.9)
650408-2-B	316 stainless	316 stainless	65444-2-B	4" (101)	1/2" NPT(F)	1-1/4" NPT(F)	65108-X	637010-4	1-1/4" NPT(F)	3/4" NPT(F)	35.0 (15.9)
650408-4-B	316 stainless	316 stainless	65444-B	4" (101)	1/2" NPT(F)	1-1/4" NPT(F)	65108-X	637010-4	1-1/4" NPT(F)	3/4" NPT(F)	35.0 (15.9)
650408-5-B	316 stainless	316 stainless*	65444-B	4" (101)	1/2" NPT(F)	1-1/4" NPT(F)	65108-X	637010	1-1/4" NPT(F)	3/4" NPT(F)	35.0 (15.9)
650408-6-B	316 stainless	316 stainless*	65444-B	4" (101)	1/2" NPT(F)	1-1/4" NPT(F)	65108-X	637010-4	1-1/4" NPT(F)	3/4" NPT(F)	35.0 (15.9)
650408-7-B	316 stainless	316 stainless*	65444-B	4" (101)	1/2" NPT(F)	1-1/4" NPT(F)	65108-X	637010-5	1-1/4" NPT(F)	3/4" NPT(F)	35.0 (15.9)
650408-8-B	316 stainless	316 stainless	65444-B	4" (101)	1/2" NPT(F)	1-1/4" NPT(F)	65108-X	637010-5	1-1/4" NPT(F)	3/4" NPT(F)	35.0 (15.9)

*Ceramic coating.

9:1 Ratio, 4-1/4" Air Motor, 2-Ball Lower End

6 5 0 4 0 9 - X

6 5 0 4 0 9

Configuration

Teflon packings
Plain rod and tube
Standard motor

Packings

1 – UHMW-PE (upper/lower), plain rod and tube, counter motor
4 – UHMW-PE (upper/lower), plain rod and tube, standard motor

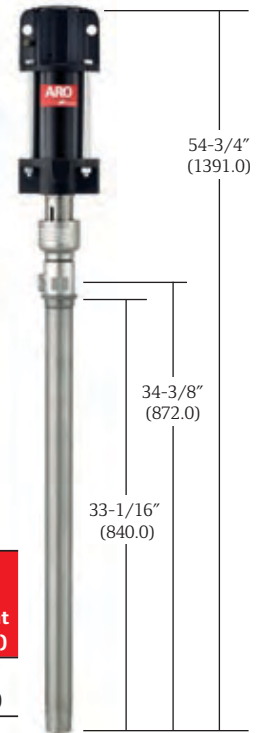

650409
650409-4

Available Models	Lower Pump Material	Plunger Material	Air Motor	Stroke in (mm)	Air Inlet	Exhaust Port	Lower Pump Model	Lower Pump Repair Kit	Material Inlet	Material Outlet	Weight lb (kg)
650409	316 stainless	316 stainless	65444-B	4" (101.6)	1/2" NPT(F)	1-1/4" NPT(F)	65106-X	637010	1-1/4" NPT(F)	3/4" NPT(F)	45 (20.4)
650409-1	316 stainless	316 stainless	65444-B	4" (101.6)	1/2" NPT(F)	1-1/4" NPT(F)	65106-X	637010-4	1-1/4" NPT(F)	3/4" NPT(F)	45 (20.4)
650409-4	316 stainless	316 stainless	65444-B	4" (101.6)	1/2" NPT(F)	1-1/4" NPT(F)	65106-X	637010-4	1-1/4" NPT(F)	3/4" NPT(F)	45 (20.4)

Model	Air Inlet Pressure Range psi (bar)	Fluid Pressure Range psi (bar)	Max Cycles/Minute	Displacement per Cycle cu in (cm ³)	Cycles per gal (L)	Flow @ 60 Cycles gpm (L/min)	Noise Level @ 60 psi dBA
650409-X	0 – 150 (0 – 10.3)	0 – 1,350 (0 – 93.1)	60	11.0 (180.2)	21 (5.5)	2.9 (10.8)	80

Accessories

Part Number	Description
650409-X	
C28241-810	Air line F/R/L
66100	Wall mount
62274	Air line oil
91790	Muffler
66333-B	Wet Sol
61268	Air motor repair kit

Accessories

Part Number	Description
650408-X-B	
C28241-810	Air line F/R/L
66100	Wall mount
62274	Air line oil
91790	Muffler
66333-B	Wet Sol
61268	Air motor repair kit

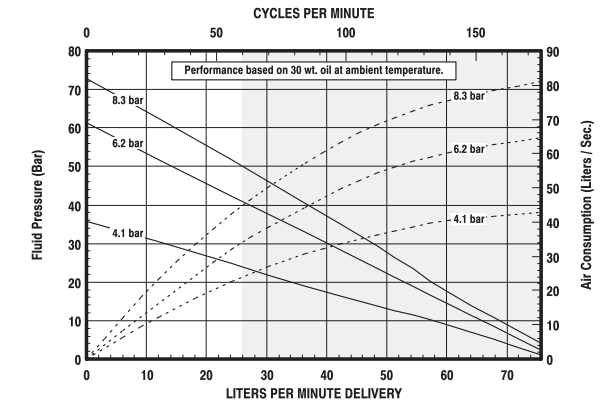
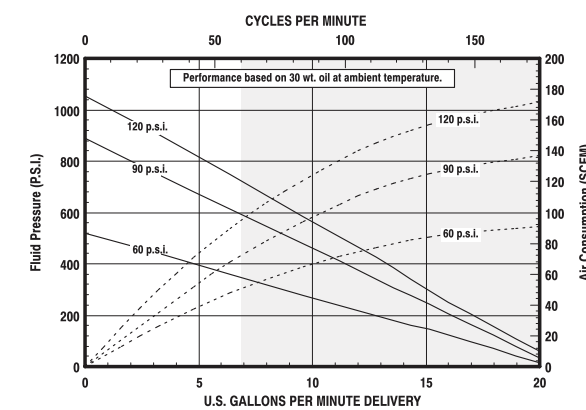
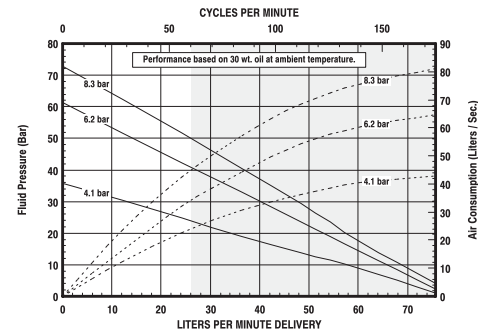
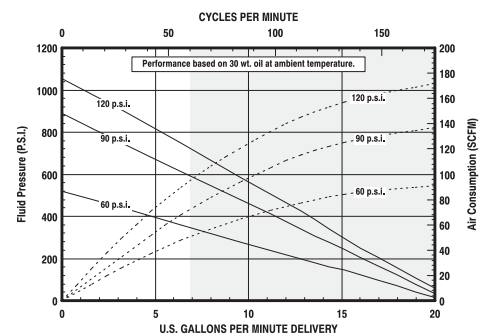

9:1 Ratio, 4-1/4" Air Motor, 2-Ball Lower End

6 5 0 4 5 3 - X

Packings/Pump types

- 5 – Teflon, 55-gal (205 L)
- 7 – Teflon/Leather staggered, stub (wall-mount)
- 8 – UHMW-PE, 55-gal (205 L)
- 9 – UHMW-PE/Leather staggered, stub (wall-mount)
- 10 – UHMW-PE, stub (wall-mount)
- 11 – Teflon, stub (wall-mount)

Model	A in (mm)	B in (mm)
650453-5, 8,	59-1/4" (1504.9)	37-1/8" (942.9)
650453-7, 9, 10, 11	32-11/16" (830.2)	10-9/16" (268.2)

Available Models	Lower Pump Material	Plunger Material	Air Motor	Stroke in (mm)	Air Inlet	Exhaust Port	Lower Pump Model	Lower Pump Repair Kit	Material Inlet	Material Outlet	Weight lb (kg)
650453-5	Carbon steel	Carbon steel*	65445-B	4" (102)	1/2" NPT(F)	—	650453-X	637177	Immersed	3/4" NPT(F)	49 (22.2)
650453-7	Carbon steel	Carbon steel*	65445-B	4" (102)	1/2" NPT(F)	—	650453-X	Order separately	1-1/2" NPT	3/4" NPT(F)	35 (15.8)
650453-8	Carbon steel	Carbon steel*	65445-B	4" (102)	1/2" NPT(F)	—	650453-X	Order separately	Immersed	3/4" NPT(F)	49 (22.2)
650453-9	Carbon steel	Carbon steel*	65445-B	4" (102)	1/2" NPT(F)	—	650453-X	Order separately	1-1/2" NPT	3/4" NPT(F)	35 (15.8)
650453-10	Carbon steel	Carbon steel*	65445-B	4" (102)	1/2" NPT(F)	—	650453-X	Order separately	1-1/2" NPT	3/4" NPT(F)	35 (15.8)
650453-11	Carbon steel	Carbon steel*	65445-B	4" (102)	1/2" NPT(F)	—	650453-X	637177	1-1/2" NPT	3/4" NPT(F)	35 (15.8)

*Hard chrome-plated.

Model	Air Inlet Pressure Range psi (bar)	Fluid Pressure Range psi (bar)	Max Cycles/Minute	Displacement per Cycle cu in (cm ³)	Cycles per gal (L)	Flow @ 60 Cycles gpm (L/min)	Noise Level @ 60 psi dBA
650453-X	0 – 150 (0 – 10.3)	0 – 1,350 (0 – 93.1)	60	11.0 (180.2)	21 (5.5)	2.8 (10.5)	80

Accessories

Part Number	Description
650453-X	
C28241-810	Air line F/R/L
61113	Wall mount
62274	Air line oil
91790	Muffler
66333-B	Wet Sol
61268	Air motor repair kit

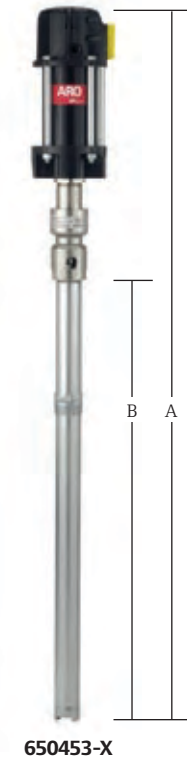

650453-X

10:1 Ratio, 8" Air Motor, 2-Ball Lower End

6 1 3 1 1 2 - X X F - C

Packings/Springs

- C6 – UHMW-PE, multiple-wave spring
- CD – UHMW-PE, multiple-wave spring with alternate seat material
- K3 – CG-filled Teflon, no spring
- KC – CG-filled Teflon, no spring with alternate seat material
- L6 – Mineral-filled Teflon, multiple-wave spring
- LD – Mineral-filled Teflon, multiple-wave spring with alternate seat material
- P6 – UHMW-PE/Teflon staggered (upper)/UHMW-PE (lower), multiple-wave spring
- PD – UHMW-PE/Teflon staggered (upper)/UHMW-PE (lower), multiple-wave spring with alternate seat material
- R6 – Teflon/UHMW-PE staggered (upper)/mineral-filled Teflon (lower), multiple-wave spring
- RD – Teflon/UHMW-PE staggered (upper)/mineral-filled Teflon (lower), multiple-wave spring with alternate seat material

Model	Lower Pump Material	Plunger Material	Air Motor	Stroke in (mm)	Air Inlet	Exhaust Port	Lower Pump Model	Material Inlet	Material Outlet	Weight lb (kg)
613112-XXF-C	316 stainless steel	321 stainless steel*	66523-B	6" (152)	3/4" NPT(F)	1-1/4" NPT(F)	66942-XXF	2" NPT(F)	1-1/4" NPT(F)	102 (46.3)

*Hard chrome-plated.

Model	Air Inlet Pressure Range psi (bar)	Fluid Pressure Range psi (bar)	Max Cycles/Minute	Displacement per Cycle cu in (cm ³)	Cycles per gal (L)	Flow @ 70 Cycles gpm (L/min)	Noise Level @ 60 psi dBA
613112-XXF-C	30 – 120 (2.1 – 8.3)	300 – 1,200 (20.7 – 82.8)	70	59.8 (979.9)	3.9 (1.0)	18.1 (68.6)	89.8 w/ muffler

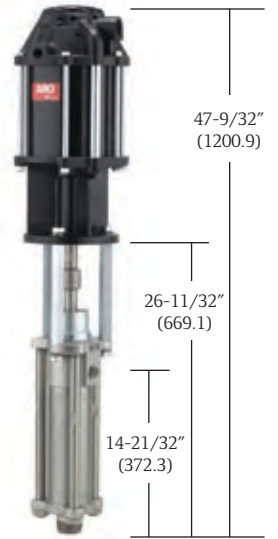

613112-XXF-C

Accessories

Part Number	Description
613112-XXF-C	
28353	Air line F/R/L
66542	Wall mount
67187-1	Mounting post
62274	Air line oil
92460	Muffler
66333-B	Wet Sol
67136	Floor/follower plate adapter
66614	Air motor repair kit
637211-X63	Lower pump repair kit

Reference mounting footprint "A" for related rams and accessories.

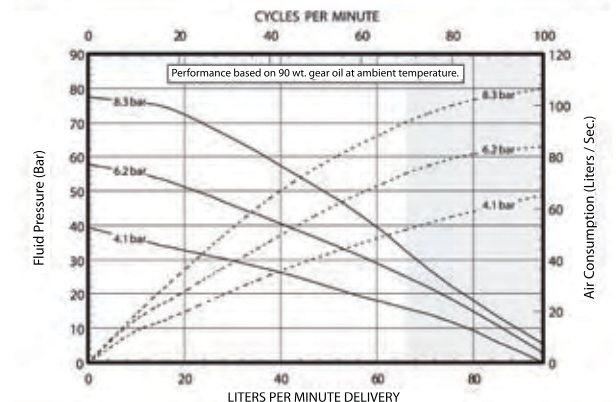
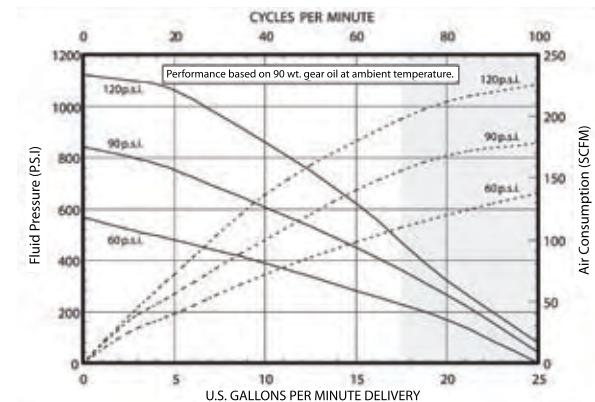

10:1 Ratio, 8" Air Motor, 2-Ball Lower End

6 5 0 8 6 6 - X X D - B

Packings/Springs

- C6 – UHMW-PE, multiple-wave spring
- CD – UHMW-PE, multiple-wave spring with alternate seat material
- L6 – Mineral-filled Teflon, multiple-wave spring
- LD – Mineral-filled Teflon, multiple-wave spring with alternate seat material
- PD – UHMW-PE / Teflon staggered (upper) / UHMW-PE (lower), multiple-wave spring with alternate seat material
- R6 – Teflon / UHMW-PE staggered (upper) / mineral-filled Teflon (lower), multiple-wave spring
- RD – Teflon / UHMW-PE staggered (upper) / mineral-filled Teflon (lower), multiple-wave spring with alternate seat material



650866-X6D-B

Model	Lower Pump Material	Plunger Material	Air Motor	Stroke in (mm)	Air Inlet	Exhaust Port	Lower Pump Model	Material Inlet	Material Outlet	Weight lb (kg)
650866-XXD-B	15-5 stainless steel*	15-5 stainless steel*	66523-B	6" (152)	3/4" NPT(F)	1-1/4" NPT(F)	66941-XXD	2" NPT(F)	1-1/4" NPT(F)	102 (46.3)

*Hard chrome-plated.

Accessories

Model	Air Inlet Pressure Range psi (bar)	Fluid Pressure Range psi (bar)	Max Cycles/Minute	Displacement per Cycle cu in (cm ³)	Cycles per gal (L)	Flow @ 70 Cycles gpm (L/min)	Noise Level @ 60 psi dBA
650866-XXD-B	30 – 120 (2.1 – 8.3)	300 – 1,200 (20.7 – 82.8)	70	59.8 (979.9)	3.9 (1.0)	18.1 (68.6)	89.8 w/ muffler

Part Number	Description
650866-XXD-B	
28353	Air line F/R/L
66542	Wall mount
67187-1	Mounting post
62274	Air line oil
92460	Muffler
66333-B	Wet Sol
67136	Floor / follower plate adapter
66614	Air motor repair kit
637211-X63	Lower pump repair kit

Reference mounting footprint "A" for related rams and accessories.

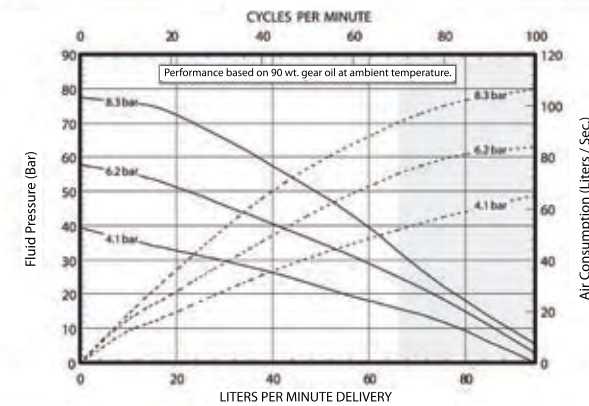
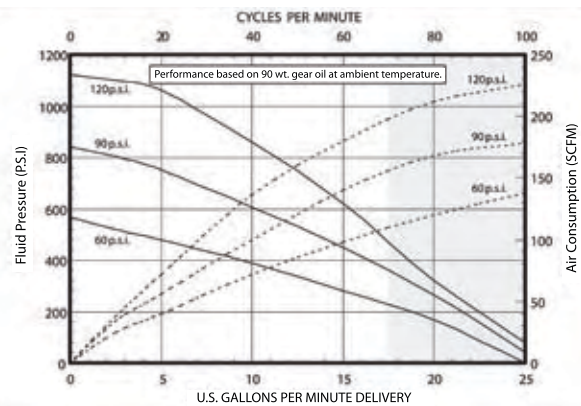

11:1 Ratio, 4-1/4" Air Motor, 2-Ball Lower End

6 5 0 4 8 3 - X 4 X

Packings/Plungers

- 343 – Glass-filled Teflon, 17-4 stainless steel (hard chrome-plated)
- 34B – Glass-filled Teflon, 17-4 stainless steel (ceramic-coated)
- C43 – UHMW-PE, 17-4 stainless steel (hard chrome-plated)
- C4B – UHMW-PE, 17-4 stainless steel (ceramic-coated)
- G43 – UHMW-PE / Leather staggered, 17-4 stainless steel (hard chrome-plated)
- P43 – UHMW-PE / Teflon staggered (upper) / UHMW-PE (lower), 17-4 stainless steel (hard chrome-plated)
- P4B – UHMW-PE / Teflon staggered (upper) / UHMW-PE (lower), 17-4 stainless steel (ceramic-coated)
- R43 – Teflon / UHMW-PE staggered (upper) / Teflon (lower), 17-4 stainless steel (hard chrome-plated)
- R4B – Teflon / UHMW-PE staggered (upper) / Teflon (lower), 17-4 stainless steel (ceramic-coated)

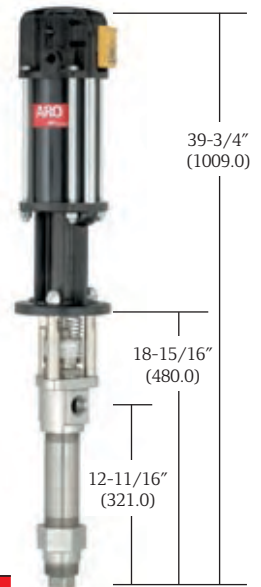

650483-X4X

Model	Lower Pump Material	Plunger Material	Air Motor	Stroke in (mm)	Air Inlet	Exhaust Port	Lower Pump Model	Material Inlet	Material Outlet	Weight lb (kg)
650483-X4X	316 stainless steel	17-4 stainless steel*	65465-B	6" (152)	1/2" NPT(F)	1-1/4" NPT(F)	66300-XXX	1" NPT(F) 2" NPT(M)	1" NPT(F)	42.9 (19.5)

*Hard chrome-plated or ceramic coating.

Accessories

Model	Air Inlet Pressure Range psi (bar)	Fluid Pressure Range psi (bar)	Max Cycles/Minute	Displacement per Cycle cu in (cm ³)	Cycles per gal (L)	Flow @ 60 Cycles gpm (L/min)	Noise Level @ 60 psi dBA
650483-X4X	30 – 150 (2.1 – 10.3)	330 – 1,747 (22.7 – 120.4)	60	14.5 (237.6)	15.9 (4.2)	3.7 (14.0)	8.18 w/ muffler

Part Number	Description
650483-X4X	
C28241-810	Air line F/R/L
66101	Wall mount
62274	Air line oil
91790	Air motor muffler
66333-B	Wet Sol
67136	Floor / follower plate adapter
65138	Floor mount
61268	Air motor repair kit
637305-X43	Lower pump repair kit

Reference mounting footprint "A" or "D" for related rams and accessories.

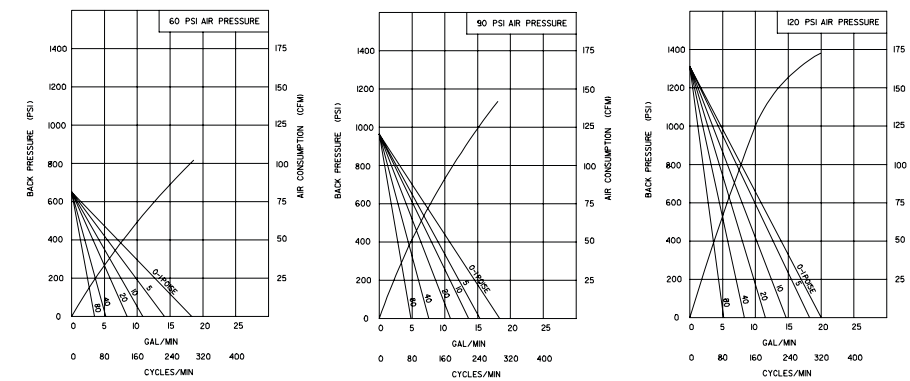

15:1 Ratio, 10" Air Motor, 2-Ball Lower End

6 5 0 8 6 7 - X X D - B

Packings/Springs

- C6 – UHMW-PE, multiple-wave spring
- CD – UHMW-PE, multiple-wave spring with alternate seat material
- L6 – Mineral-filled Teflon, multiple-wave spring
- LD – Mineral-filled Teflon, multiple-wave spring with alternate seat material
- PD – UHMW-PE/Teflon staggered (upper)/UHMW-PE (lower), multiple-wave spring with alternate seat material
- R6 – Teflon/UHMW-PE staggered (upper)/Mineral-filled Teflon (lower), multiple-wave spring
- RD – Teflon/UHMW-PE staggered (upper)/Mineral-filled Teflon (lower), multiple-wave spring with alternate seat material



650867-X6D-B

Model	Lower Pump Material	Plunger Material	Air Motor	Stroke in (mm)	Air Inlet	Exhaust Port	Lower Pump Model	Material Inlet	Material Outlet	Weight lb (kg)
650867-XXD-B	15-5 stainless steel*	15-5 stainless steel*	66651-B	6" (152)	3/4" NPT(F)	1-1/4" NPT(F) 3/4" NPT(F)	66941-XXD	2" NPT(M)	1-1/4" NPT(F)	125 (56.7)

*Hard chrome-plated.

Model	Air Inlet Pressure Range psi (bar)	Max Fluid Pressure psi (bar)	Max Cycles/Minute	Displacement per Cycle cu in (cm ³)	Cycles per gal (L)	Flow @ 60 Cycles gpm (L/min)	Noise Level @ 60 psi dBA
650867-XXD-B	30 – 90 (2.1 – 6.2)	450 – 1,350 (31.0 – 93.1)	70	59.8 (979.9)	3.9 (1.0)	18.1 (68.6)	84.8 w/ muffler

Accessories

Part Number	Description
650867-XXD-B	
28353	Air line F/R/L
66542	Wall mount
62274	Air line oil
66718	Muffler
66333-B	Wet Sol
67136	Floor/follower plate adapter
637110	Air motor repair kit
637211-X63	Lower pump repair kit

Reference mounting footprint "A" for related rams and accessories.

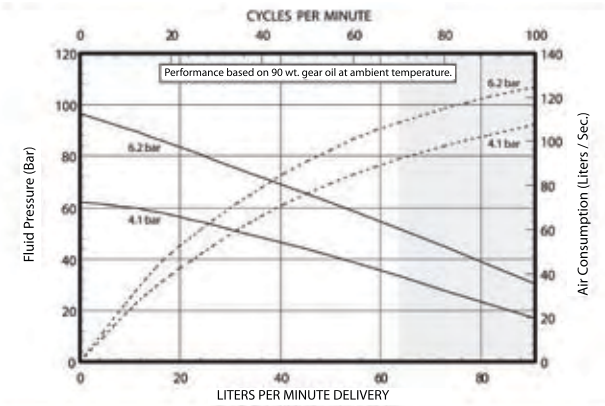
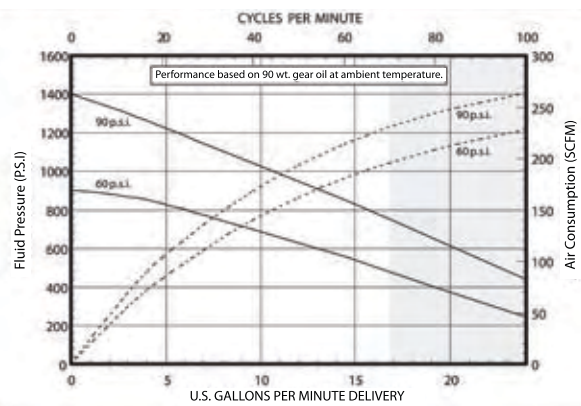

15:1 Ratio, 10" Air Motor, 2-Ball Lower End

6 1 3 1 2 3 - X X F - C

Packings/Springs

- C6 – UHMW-PE, multiple-wave spring
- CD – UHMW-PE, multiple-wave spring with alternate seat material
- K3 – CG-filled Teflon, no spring
- KC – CG-filled Teflon, no spring with alternate seat material
- LD – Mineral-filled Teflon, multiple-wave spring with alternate seat material
- P6 – UHMW-PE/Teflon staggered (upper)/UHMW-PE (lower), multiple-wave spring
- PD – UHMW-PE/Teflon staggered (upper)/UHMW-PE (lower), multiple-wave spring with alternate seat material
- RD – Teflon/UHMW-PE staggered (upper)/Mineral-filled Teflon (lower), multiple-wave spring with alternate seat material

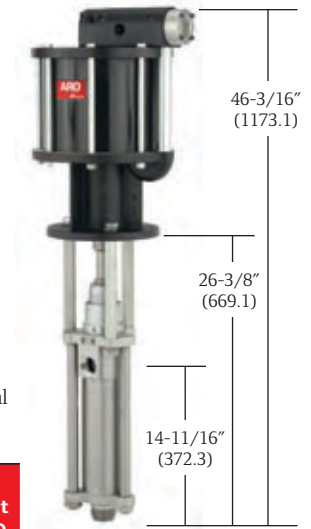

613123-XXF-C

Model	Lower Pump Material	Plunger Material	Air Motor	Stroke in (mm)	Air Inlet	Exhaust Port	Lower Pump Model	Material Inlet	Material Outlet	Weight lb (kg)
613123-XXF-C	304 stainless steel*	321 stainless steel*	66651-B	6" (152)	3/4" NPT(F)	1-1/4" NPT(F) 3/4" NPT(F)	66942-XXF	2" NPT(F)	1-1/4" NPT(F)	125 (56.7)

*Hard chrome-plated.

Model	Air Inlet Pressure Range psi (bar)	Fluid Pressure Range psi (bar)	Max Cycles/Minute	Displacement per Cycle cu in (cm ³)	Cycles per gal (L)	Flow @ 70 Cycles gpm (L/min)	Noise Level @ 60 psi dBA
613123-XXF-C	30 – 90 (2.1 – 6.2)	450 – 1,350 (31.0 – 93.1)	70	59.8 (979.9)	3.9 (1.0)	18.1 (68.6)	84.8 w/ muffler

Accessories

Part Number	Description
613123-XXF-C	
28353	Air line F/R/L
66542	Wall mount
62274	Air line oil
66718	Muffler
66333-B	Wet Sol
67136	Floor/follower plate adapter
637110	Air motor repair kit
637211-X63	Lower pump repair kit

Reference mounting footprint "A" for related rams and accessories.

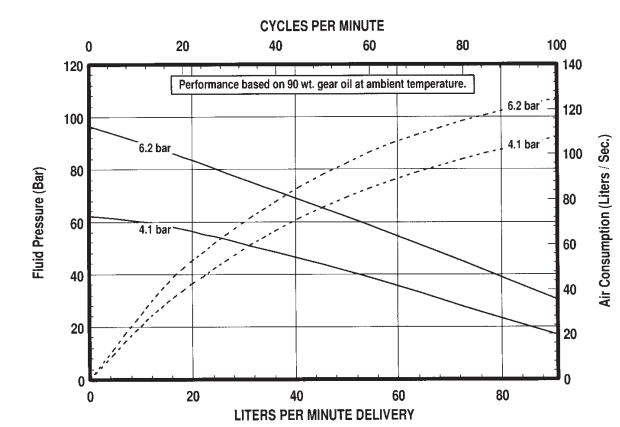
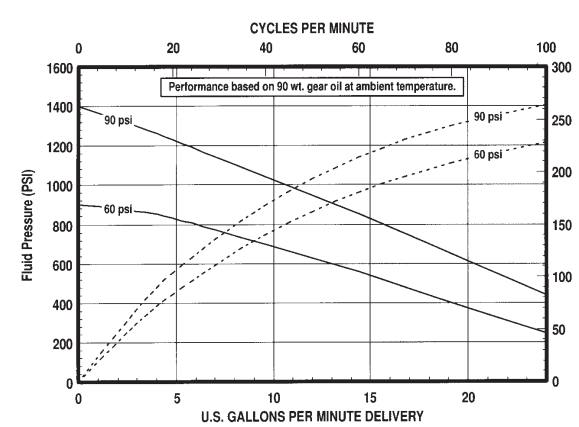

18:1 Ratio, 3" Air Motor, 2-Ball Lower End

N M 2 3 1 8 B - 1 3 - X 4 3

Packings

C – UHMW-PE (upper and lower)
L – Mineral-filled Teflon (upper and lower)

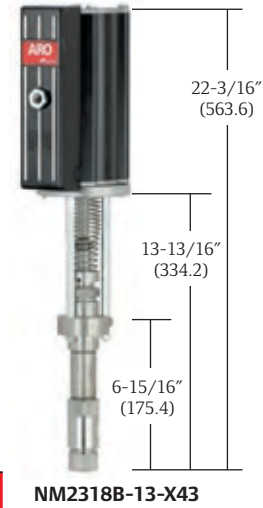

NM2318B-13-X43

Available Models	Lower Pump Material	Plunger Material	Air Motor	Stroke in (mm)	Air Inlet	Exhaust Port	Lower Pump Model	Material Inlet	Material Outlet	Weight lb (kg)
NM2318B-13-C43	304 stainless steel*	17-4 stainless steel*	66917	3" (76)	1/4" NPT(F)	—	67310-X-X	1/2" NPT(F)	1/4" NPT(F)	12.6 (5.7)
NM2318B-13-L43	304 stainless steel*	17-4 stainless steel*	66917	3" (76)	1/4" NPT(F)	—	67310-X-X	1/2" NPT(F)	1/4" NPT(F)	12.6 (5.7)

*Hard chrome-plated.

Accessories

Part Number	Description
NM2318B-13-X43	
P29122-600	Piggyback F/R
95015	Wall mount
66333-B	Wet Sol
637316	Air motor repair kit
637394-X43	Lower pump repair kit

Reference mounting footprint "A" for related rams and accessories.

Model	Air Inlet Pressure Range psi (bar)	Fluid Pressure psi (bar)	Max Cycles/Minute	Displacement per Cycle cu in (cm ³)	Cycles per gal (L)	Flow @ 60 Cycles gpm (L/min)	Noise Level @ 60 psi dBA
NM2318B-13-X43	0 – 150 (0 – 10.3)	0 – 2,700 (0 – 186.2)	120	2.3 (37.6)	98.3 (26.5)	0.6 (2.3)	85

22:1 Ratio, 4-1/4" Air Motor, 2-Ball Lower End

6 5 0 4 8 4 - X 4 X

Packings/Plungers

343 – Glass-filled Teflon, 17-4 stainless steel (hard chrome-plated)
C43 – UHMW-PE, 17-4 stainless steel (hard chrome-plated)
G43 – UHMW-PE/Leather staggered, 17-4 stainless steel (hard chrome-plated)
P43 – UHMW-PE/Teflon staggered (upper)/UHMW-PE (lower), 17-4 stainless steel (hard chrome-plated)
R43 – Teflon/UHMW-PE staggered (upper)/Teflon (lower), 17-4 stainless steel (hard chrome-plated)
R4B – Teflon/UHMW-PE staggered (upper)/Teflon (lower), 17-4 stainless steel (ceramic coating)

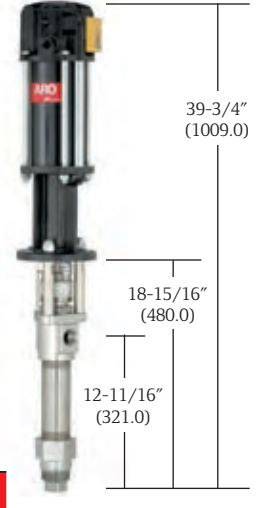

650484-X4X

Model	Lower Pump Material	Plunger Material	Air Motor	Stroke in (mm)	Air Inlet	Exhaust Port	Lower Pump Model	Material Inlet	Material Outlet	Weight lb (kg)
650484-X4X	316 stainless steel	17-4 stainless steel*	65465-B	6" (152)	1/2" NPT(F)	1-1/4" NPT(F)	66301-X4X	1" NPT(F) 2" NPT(M)	1" NPT(F)	42.9 (19.5)

*Hard chrome-plated or ceramic coating.

Accessories

Part Number	Description
650484-X4X	
C28241-810	Air line F/R/L
66101	Wall mount
62274	Air line oil
91790	Air motor muffler
66333-B	Wet Sol
66136	Floor/follower plate adapter
65138	Floor mount
61268	Air motor repair kit
637306-X43	Lower pump repair kit

Reference mounting footprint "A" or "D" for related rams and accessories.

Model	Air Inlet Pressure Range psi (bar)	Fluid Pressure Range psi (bar)	Max Cycles/Minute	Displacement per Cycle cu in (cm ³)	Cycles per gal (L)	Flow @ 60 Cycles gpm (L/min)	Noise Level @ 60 psi dBA
650484-X4X	30 – 150 (2.1 – 10.3)	660 – 3,412 (45.5 – 235.2)	60	7.5 (122.9)	30.9 (8.1)	1.9 (7.2)	81.8 w/ muffler

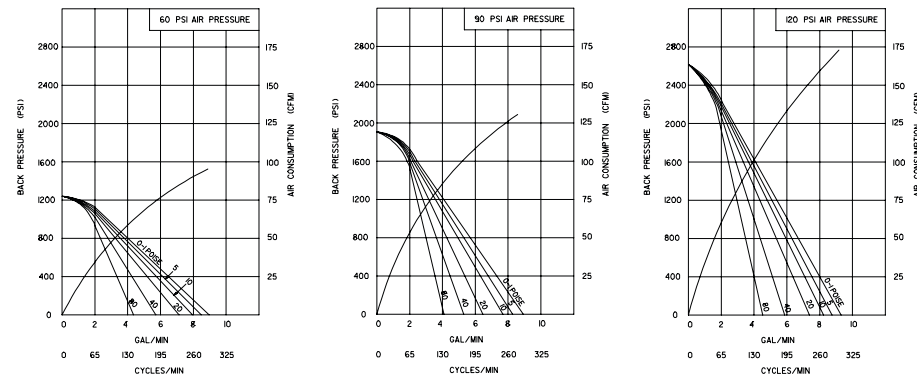

23:1 Ratio, 6" Air Motor, 2-Ball Lower End

6 5 0 6 8 3 - X 4 X

Packings/Plungers

- 343 – Glass-filled Teflon, 17-4 stainless steel (hard chrome-plated)
- 34B – Glass-filled Teflon, 17-4 stainless steel (ceramic-coated)
- C43 – UHMW-PE, 17-4 stainless steel (hard chrome-plated)
- C4B – UHMW-PE, 17-4 stainless steel (ceramic-coated)
- G43 – UHMW-PE/Leather staggered, 17-4 stainless steel (hard chrome-plated)
- G4B – UHMW-PE/Leather staggered, 17-4 stainless steel (ceramic-coated)
- P43 – UHMW-PE/Teflon staggered (upper)/UHMW-PE (lower), 17-4 stainless steel (hard chrome-plated)
- P4B – UHMW-PE/Teflon staggered (upper)/UHMW-PE (lower), 17-4 stainless steel (ceramic-coated)
- R43 – Teflon/UHMW-PE staggered (upper)/Teflon (lower), 17-4 stainless steel (hard chrome-plated)
- R4B – Teflon/UHMW-PE staggered (upper)/Teflon (lower), 17-4 stainless steel (ceramic coating)

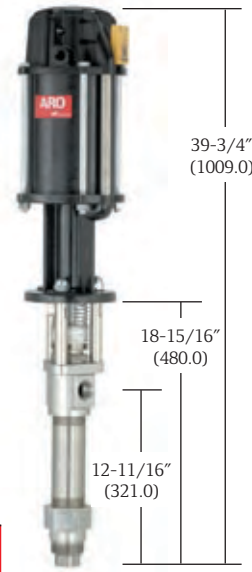

650683-X4X

Model	Lower Pump Material	Plunger Material	Air Motor	Stroke in (mm)	Air Inlet	Exhaust Port	Lower Pump Model	Material Inlet	Material Outlet	Weight lb (kg)
650683-X4X	316 stainless steel	17-4 stainless steel*	65665-B	6" (152)	1/2" NPT(F)	1-1/4" NPT(F)	66300-XXX	1" NPT(F) 2" NPT(M)	1" NPT(F)	46.2 (21.0)

*Hard chrome-plated or ceramic coating.

23:1 Ratio, 12" Air Motor, 2-Ball Lower End

6 5 0 9 6 7 - X X D - B

Packings/Springs

- C6 – UHMW-PE, multiple-wave spring
- CD – UHMW-PE, multiple-wave spring with alternate seat material
- L6 – Mineral-filled Teflon, multiple-wave spring
- LD – Mineral-filled Teflon, multiple-wave spring with alternate seat material
- P6 – UHMW-PE/Teflon staggered (upper)/UHMW-PE (lower), multiple-wave spring
- PD – UHMW-PE/Teflon staggered (upper)/UHMW-PE (lower), multiple-wave spring with alternate seat material
- RD – Teflon/UHMW-PE staggered (upper)/Mineral-filled Teflon (lower), multiple-wave spring with alternate seat material

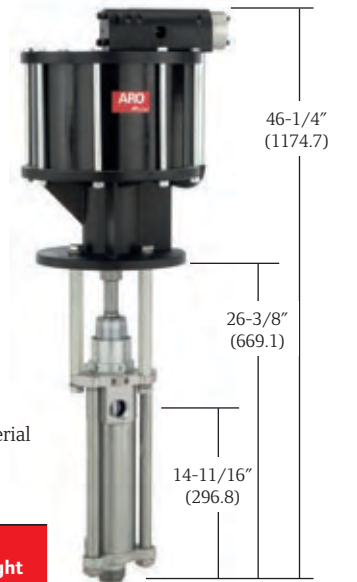

650967-X6D-B

Model	Lower Pump Material	Plunger Material	Air Motor	Stroke in (mm)	Air Inlet	Exhaust Port	Lower Pump Model	Material Inlet	Material Outlet	Weight lb (kg)
650967-XXD-B	15-5 stainless steel*	15-5 stainless steel*	66506-B	6" (152)	3/4" NPT(F)	1-1/4" NPT(F) 3/4" NPT(F)	66941-XXD	2" NPT(M)	1-1/4" NPT(F)	140 (63.5)

*Hard chrome-plated.

Accessories

Part Number	Description
650683-X4X	
C28241-810	Air line F/R/L
66101	Wall mount
62274	Air line oil
91790	Air motor muffler
66333-B	Wet Sol
67136	Floor/follower plate adapter
65138	Floor mount
61355	Air motor repair kit
637305-X43	Lower pump repair kit

Reference mounting footprint "A" or "D" for related rams and accessories.

Accessories

Part Number	Description
650967-XXD-B	
28353	Air line F/R/L
66542	Wall mount
62274	Air line oil
66718	Muffler
66333-B	Wet Sol
67136	Floor/follower plate adapter
637112	Air motor repair kit
637211-X63	Lower pump repair kit

Reference mounting footprint "A" for related rams and accessories.

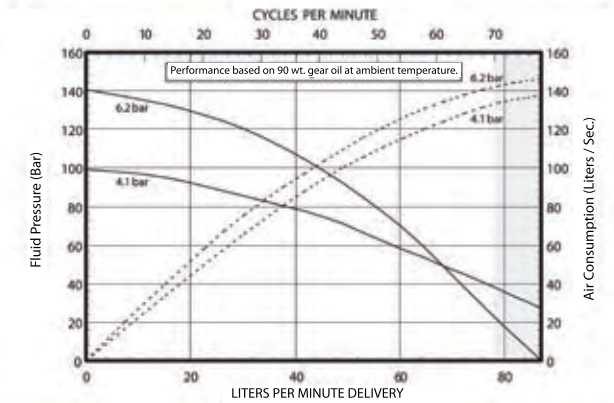
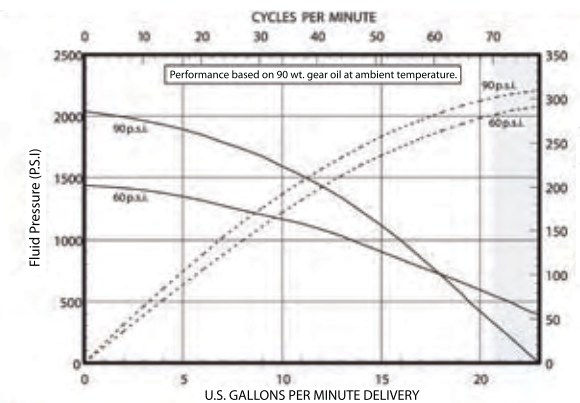
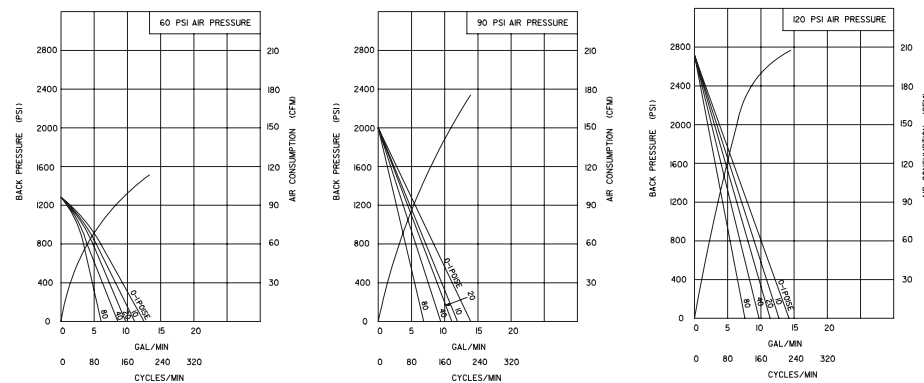

23:1 Ratio, 12" Air Motor, 2-Ball Lower End

6 1 3 1 2 4 - X X F - C

Packings/Springs

- C6 – UHMW-PE, multiple-wave spring
- CD – UHMW-PE, multiple-wave spring with alternate seat material
- KC – CG-filled Teflon, no spring with alternate seat material
- L6 – Mineral-filled Teflon, multiple-wave spring
- LD – Mineral-filled Teflon, multiple-wave spring with alternate seat material
- PD – UHMW-PE/Teflon staggered (upper)/UHMW-PE (lower), multiple-wave spring with alternate seat material
- R6 – Teflon/UHMW-PE staggered (upper)/Mineral-filled Teflon (lower), multiple-wave spring
- RD – Teflon/UHMW-PE staggered (upper)/Mineral-filled Teflon (lower), multiple-wave spring with alternate seat material

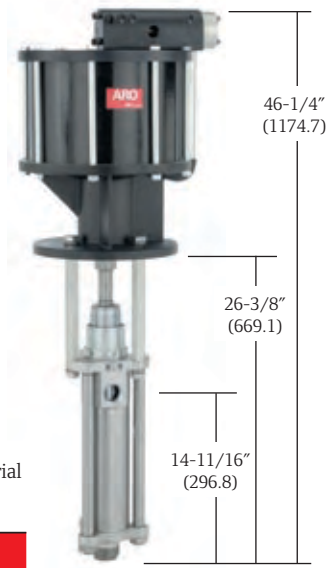

613124-XXF-C

Model	Material	Lower Pump Material	Plunger Motor	Air in (mm)	Stroke Inlet	Air Port	Exhaust Model	Lower Pump Inlet	Material Outlet	Material lb (kg)	Weight
613124-XXF-C		304 stainless steel*	321 stainless steel*	66506-B	6"	3/4" NPT(F)	1-1/4" NPT(F) 3/4" NPT(F)	66942-XXF	2" NPT(F)	1-1/4" (63.5)	140

*Hard chrome-plated.

Accessories

Part Number	Description
613124-XXF-C	
28353	Air line F/R/L
66542	Wall mount
62274	Air line oil
66718	Muffler
66333-B	Wet Sol
67136	Floor/follower plate adapter
637112	Air motor repair kit
637211-XX3	Lower pump repair kit

Reference mounting footprint "A" for related rams and accessories.

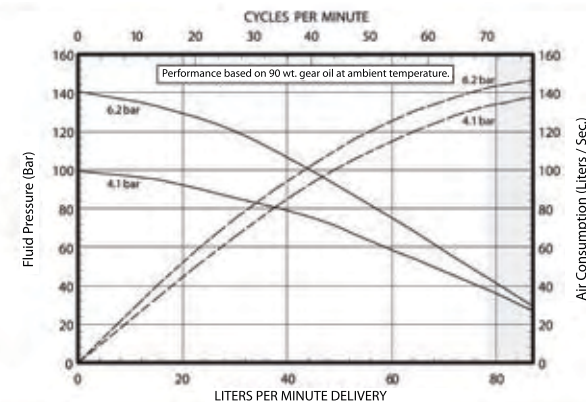
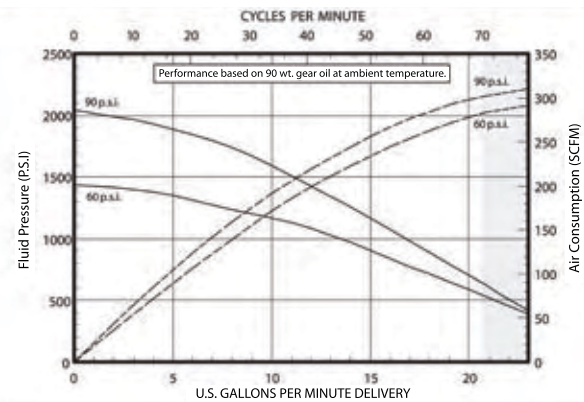

28:1 Ratio, 3" Air Motor, 2-Ball Lower End

N M 2 3 2 8 A - 1 1 - X 1 1

Packings

- 3 – Glass-filled Teflon
- G – UHMW-PE/Leather staggered
- S – UHMW-PE/Glass-filled Teflon staggered

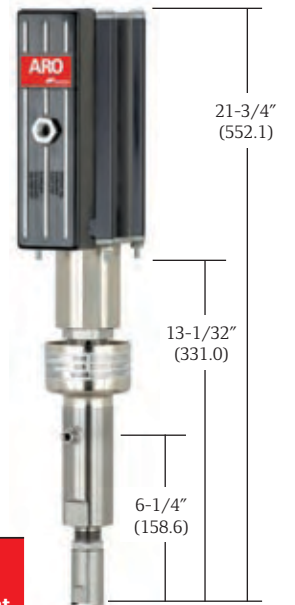

NM2328A-11-X11

Available Models	Lower Pump Material	Plunger Material	Air Motor	Stroke in (mm)	Air Inlet	Exhaust Port	Lower Pump Model	Lower Pump Repair Kit	Material Inlet	Material Outlet	Weight lb (kg)
NM2328A-11-311	440 stainless steel	440 stainless steel	66914	3" (76)	1/4" NPT(F)	—	66066-1	637006-3	1/2" NPT(F)	1/4" NPT(M)	13 (5.9)
NM2328A-11-G11	440 stainless steel	440 stainless steel	66914	3" (76)	1/4" NPT(F)	—	66066-2	637006-2	1/2" NPT(F)	1-1/4" NPT(M)	13 (5.9)
NM2328A-11-S11	440 stainless steel	440 stainless steel	66914	3" (76)	1/4" NPT(F)	—	66066-3	637006-3	1/2" NPT(F)	1-1/4" NPT(M)	13 (5.9)

Model	Air Inlet Pressure Range psi (bar)	Fluid Pressure Range psi (bar)	Max Cycles/Minute	Displacement per Cycle cu in (cm³)	Cycles per gal (L)	Flow @ 60 Cycles gpm (L/min)	Noise Level @ 100 psi dBA
NM2328A-11-X11	0 – 150 (0 – 10.3)	0 – 4,200 (0 – 289.7)	125	1.4 (22.9)	157.5 (43.5)	0.38 (1.4)	85

Accessories

Part Number	Description
NM2328A-11-X11	
P29122-600	Piggyback F/R
61113	Wall mount
66333-B	Wet sol
637316	Air motor repair kit
637006-X	Lower end repair kit

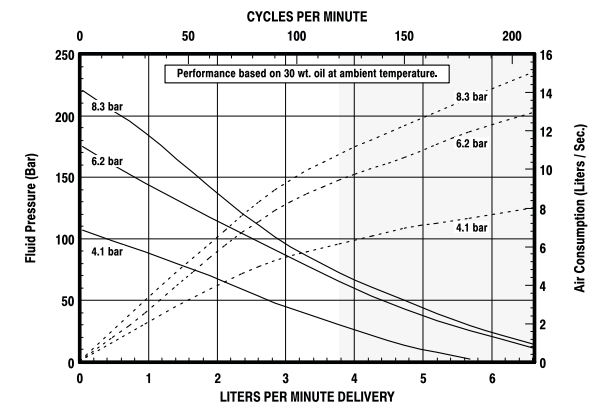
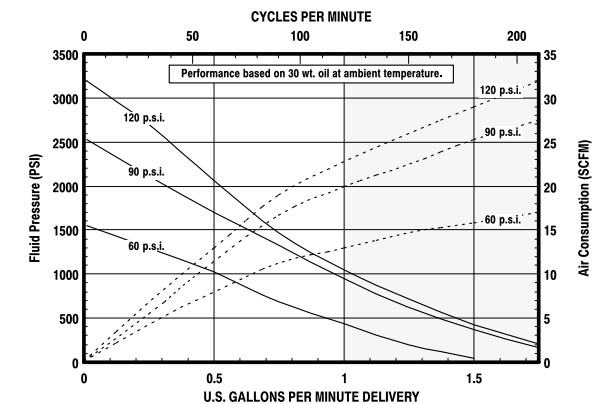

30:1 Ratio, 4-1/4" Air Motor, 2-Ball Lower End

6 5 0 4 8 5 - X 4 X

Packings/Plungers

- 343 – Glass-filled Teflon, 17-4 stainless steel (hard chrome-plated)
- C43 – UHMW-PE, 17-4 stainless steel (hard chrome-plated)
- G43 – UHMW-PE/Leather staggered, 17-4 stainless steel (hard chrome-plated)
- G4B – UHMW-PE/Leather staggered, 17-4 stainless steel (ceramic coating)
- P43 – UHMW-PE/Teflon staggered (upper)/UHMW-PE (lower), 17-4 stainless steel (hard chrome-plated)
- P4B – UHMW-PE/Teflon staggered (upper)/UHMW-PE (lower), 17-4 stainless steel (ceramic coating)
- R43 – Teflon/UHMW-PE staggered (upper)/Teflon (lower), 17-4 stainless steel (hard chrome-plated)

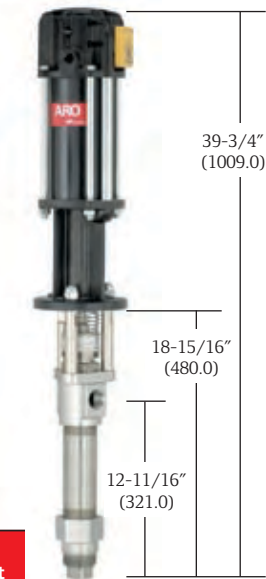

650485-X4X

Model	Lower Pump Material	Plunger Material	Air Motor	Stroke in (mm)	Air Inlet	Exhaust Port	Lower Pump Model	Material Inlet	Material Outlet	Weight lb (kg)
650485-X4X	316 stainless steel	17-4 stainless steel*	65465-B	6" (152)	1/2" NPT(F)	1-1/4" NPT(F)	66302-X4X	1" NPT(F) 2" NPT(M)	1" NPT(F)	42.9 (19.5)

*Hard chrome-plated or ceramic coating.

40:1 Ratio, 8" Air Motor, 2-Ball Lower End

6 5 0 8 8 3 - X 4 X - B

Packings/Plungers

- 34D – Glass-filled Teflon, 17-4 stainless steel (hard chrome-plated)
- C4D – UHMW-PE, 17-4 stainless steel (hard chrome-plated)
- G4G – UHMW-PE, 17-4 stainless steel (ceramic coating)
- G4D – UHMW-PE/Leather staggered, 17-4 stainless steel (hard chrome-plated)
- P4D – UHMW-PE/Teflon staggered (upper)/UHMW-PE (lower), 17-4 stainless steel (hard chrome-plated)
- R4D – Teflon/UHMW-PE staggered (upper)/Teflon (lower), 17-4 stainless steel (hard chrome-plated)
- R4G – Teflon/UHMW-PE staggered (upper)/Teflon (lower), 17-4 stainless steel (ceramic coating)

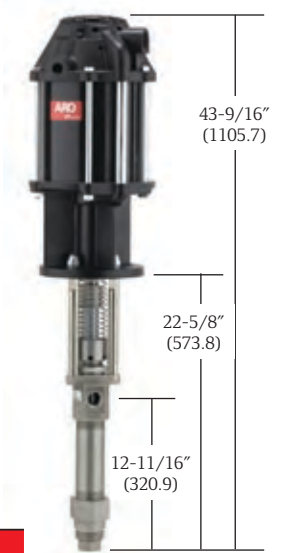

650883-X4X-B

Model	Lower Pump Material	Plunger Material	Air Motor	Stroke in (mm)	Air Inlet	Exhaust Port	Lower Pump Model	Material Inlet	Material Outlet	Weight lb (kg)
650883-X4X-B	316 stainless steel	17-4 stainless steel*	66523-B	6" (152)	3/4" NPT(F)	1-1/4" NPT(F)	66300-X4X	1" NPT(F) 2" NPT(M)	1" NPT(F)	68.1 (30.9)

*Hard chrome-plated or ceramic coating.

Accessories

Part Number	Description
650485-X4X	
C28241-810	Air line F/R/L
62274	Air line oil
91790	Air motor muffler
66333-B	Wet Sol
67136	Floor/follower plate adapter
65138	Floor mount
61268	Air motor repair kit
637307-X43	Lower pump repair kit

Reference mounting footprint "A" or "D" for related rams and accessories.

Accessories

Part Number	Description
650883-X4X-B	
C28241-810	Air line F/R/L
62274	Air line oil
66542	Wall mount
92460	Air motor muffler
66333-B	Wet Sol
67136	Floor/follower plate adapter
65138	Floor mount
66614	Air motor repair kit
637305-X43	Lower pump repair kit

Reference mounting footprint "A" or "D" for related rams and accessories.

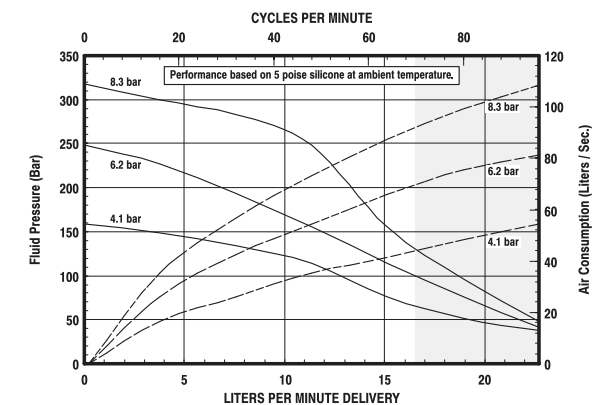
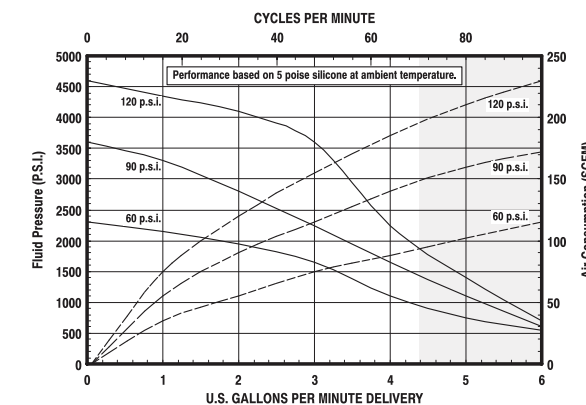
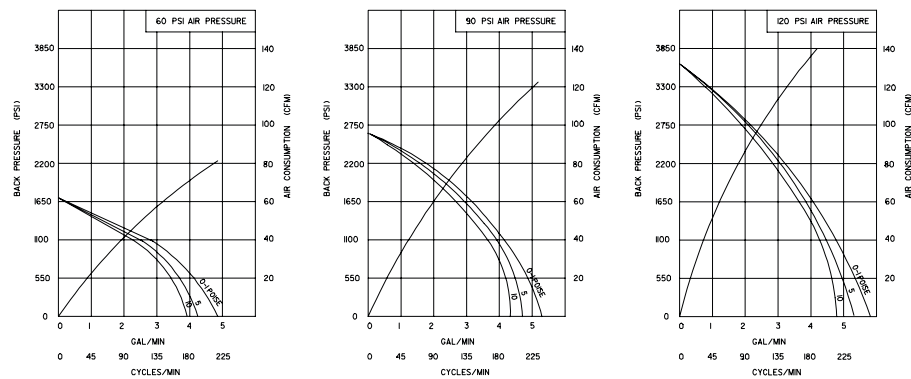

45:1 Ratio, 6" Air Motor, 2-Ball Lower End

6 5 0 6 8 4 - X 4 X

Packings/Plungers

- 343 – Glass-filled Teflon, 17-4 stainless steel (hard chrome-plated)
- C43 – UHMW-PE, 17-4 stainless steel (hard chrome-plated)
- C4B – UHMW-PE, 17-4 stainless steel (ceramic coating)
- G43 – UHMW-PE/Leather staggered, 17-4 stainless steel (hard chrome-plated)
- P43 – UHMW-PE/Teflon staggered (upper)/UHMW-PE (lower), 17-4 stainless steel (hard chrome-plated)
- R43 – Teflon/UHMW-PE staggered (upper)/Teflon (lower), 17-4 stainless steel (hard chrome-plated)
- R4B – Teflon/UHMW-PE staggered (upper)/Teflon (lower), 17-4 stainless steel (ceramic coating)

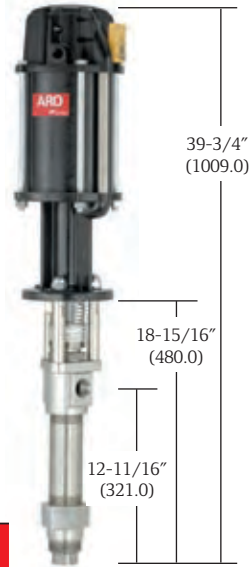

650684-X4X

Model	Lower Pump Material	Plunger Material	Air Motor	Stroke in (mm)	Air Inlet	Exhaust Port	Lower Pump Model	Material Inlet	Material Outlet	Weight lb (kg)
650684-X4X	316 stainless steel	17-4 stainless steel*	65665-B	6" (152)	1/2" NPT(F)	1-1/4" NPT(F)	66301-X4X	1" NPT(F) 2" NPT(M)	1" NPT(F)	46.2 (21.0)

*Hard chrome-plated or ceramic coating.

45:1 Ratio, 10" Air Motor, 2-Ball Lower End

6 5 0 8 6 3 - X 4 D - B

Packings

- 3 – Glass-filled Teflon
- C – UHMW-PE
- G – UHMW-PE/Leather staggered
- R – Teflon/UHMW-PE staggered (upper)/glass-filled Teflon (lower)

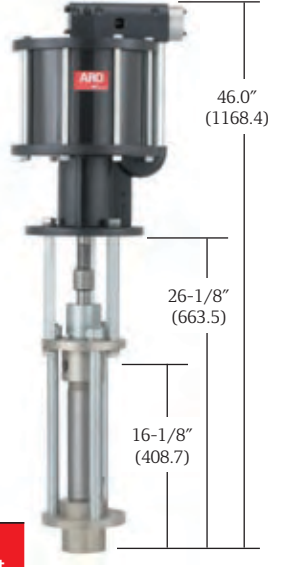

650863-X4D-B

Model	Lower Pump Material	Plunger Material	Air Motor	Stroke in (mm)	Air Inlet	Exhaust Port	Lower Pump Model	Material Inlet	Material Outlet	Weight lb (kg)
650863-X4D-B	Carbon steel*	17-4 stainless steel**	66651-B	6" (152)	3/4" NPT(F)	1-1/4" NPT(F) 3/4" NPT(F)	66475-X4D	2" NPT(F)	1" NPT(F)	132.0 (59.9)

*Nickel-plated.

**Hard chrome-plated.

Accessories

Part Number	Description
650684-X4X	
C28241-810	Air line F/R/L
62274	Air line oil
66101	Wall mount
91790	Air motor muffler
66333-B	Wet Sol
67136	Floor/follower plate adapter
61355	Air motor repair kit
637306-X43	Lower pump repair kit

Reference mounting footprint "A" or "D" for related rams and accessories.

Accessories

Part Number	Description
650863-X4D-B	
28353	Air line F/R/L
62274	Air line oil
66542	Wall mount
66718	Air motor muffler
66333-B	Wet Sol
65139	Floor mount
637110	Air motor repair kit
637098-X43	Lower pump repair kit
66554-2	Portable cart

Reference mounting footprint "B" for related rams and accessories.

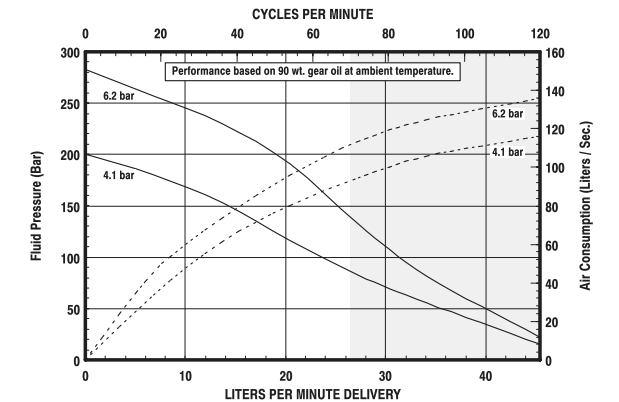
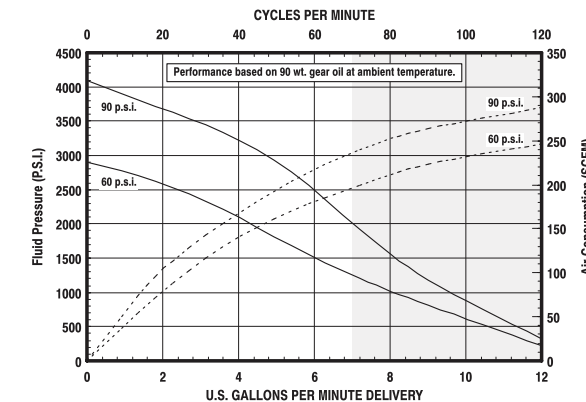
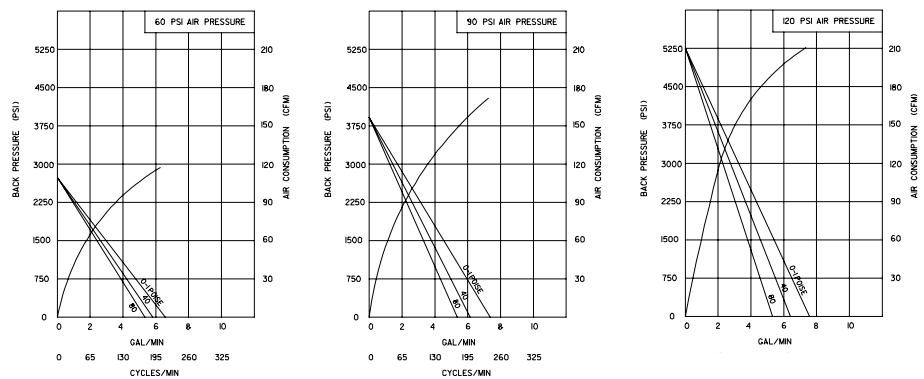

60:1 Ratio, 6" Air Motor, 2-Ball Lower End

6 5 0 6 8 5 - X 4 X

Packings/Plungers

- 343 – Glass-filled Teflon, 17-4 stainless steel (hard chrome-plated)
- 34B – Glass-filled Teflon, 17-4 stainless steel (ceramic coating)
- C43 – UHMW-PE, 17-4 stainless steel (hard chrome-plated)
- C4B – UHMW-PE, 17-4 stainless steel (ceramic coating)
- G43 – UHMW-PE/Leather staggered, 17-4 stainless steel (hard chrome-plated)
- P43 – UHMW-PE/Teflon staggered (upper)/UHMW-PE (lower), 17-4 stainless steel (hard chrome-plated)
- R43 – Teflon/UHMW-PE staggered (upper)/Teflon (lower), 17-4 stainless steel (hard chrome-plated)

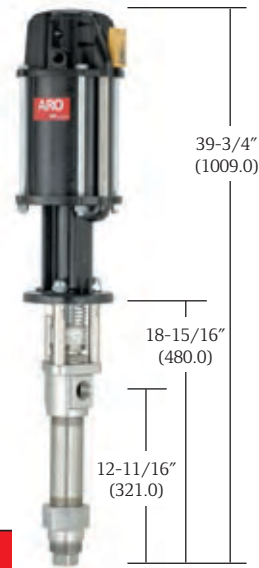

650685-X4X

Model	Lower Pump Material	Plunger Material	Air Motor	Stroke in (mm)	Air Inlet	Exhaust Port	Lower Pump Model	Material Inlet	Material Outlet	Weight lb (kg)
650685-X4X	316 stainless steel	17-4 stainless steel*	65665-B	6" (152)	1/2" NPT(F)	1-1/4" NPT(F)	66302-X4X	1" NPT(F) 2" NPT(M)	1" NPT(F)	46.2 (21.0)

*Hard chrome-plated or ceramic coating.

65:1 Ratio, 12" Air Motor, 2-Ball Lower End

6 5 0 9 6 3 - X 4 D - B

Packings

- 3 – Glass-filled Teflon
- C – UHMW-PE
- G – UHMW-PE/Leather staggered
- P – UHMW-PE/Teflon staggered (upper)/UHMW-PE (lower)
- R – Teflon/UHMW-PE staggered (upper)/Glass-filled Teflon (lower)

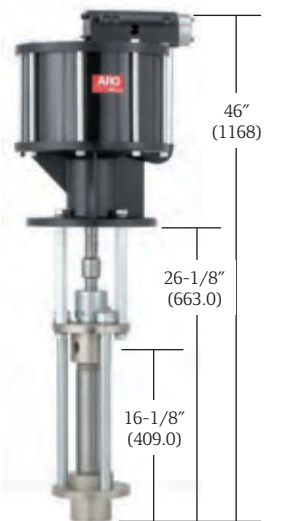

650963-X4D-B

Model	Lower Pump Material	Plunger Material	Air Motor	Stroke in (mm)	Air Inlet	Exhaust Port	Lower Pump Model	Material Inlet	Material Outlet	Weight lb (kg)
650963-X4D-B	Carbon steel*	17-4 stainless steel**	66506-B	6" (152)	3/4" NPT(F)	1-1/4" NPT(F) 3/4" NPT(F)	66475-X4D	2" NPT(F)	1" NPT(F)	147.0 (66.7)

*Nickel-plated.

**Hard chrome-plated.

Accessories

Part Number	Description
650685-X4X	
C28241-810	Air line F/R/L
66101	Wall mount
62274	Air line oil
91790	Air motor muffler
66333-B	Wet Sol
67136	Floor/follower plate adapter
61355	Air motor repair kit
637307-X43	Lower pump repair kit
67139	Portable cart

Reference mounting footprint "A" or "D" for related rams and accessories.

Accessories

Part Number	Description
650963-X4D-B	
28353	Air line F/R/L
62274	Air line oil
66542	Wall mount
66718	Air motor muffler
66333-B	Wet Sol
65139	Floor mount
637112	Air motor repair kit
637098-X43	Lower pump repair kit
66554-2	Portable cart

Reference mounting footprint "B" for related rams and accessories.

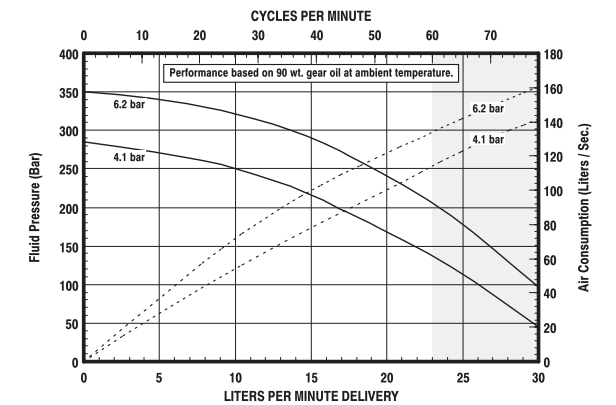
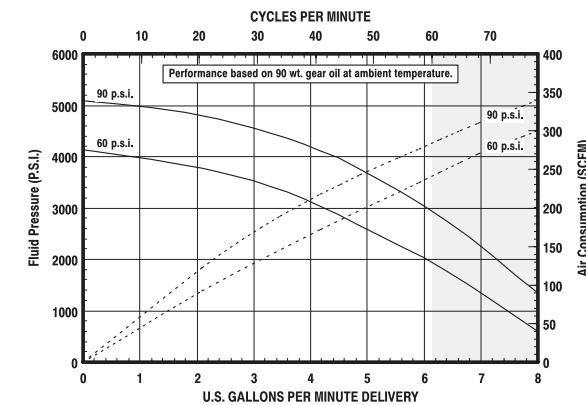
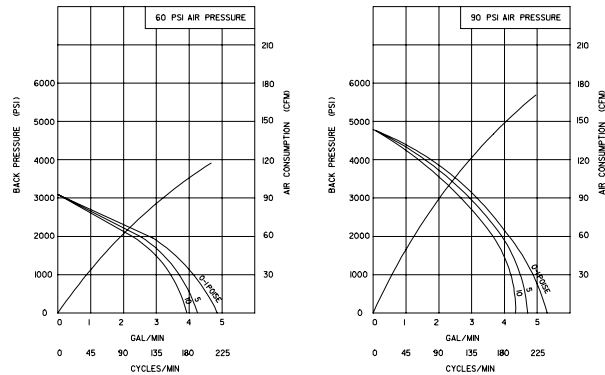

4-Ball Pumps



ARO Stinger™ 4-ball pumps are designed to transfer high volumes of low-viscosity fluids. A typical application example is circulating fluid from the original container, to the point of use, and then back.

With a flooded inlet, 4-ball pumps can handle fluid viscosities up to 12,000 cPs.

Stinger pumps are constructed of stainless steel. To maximize fluid compatibility, all stainless parts are passivated or electro-polished. These models also utilize investment cast components. This reduces the chance of porosity and results in improved machined surfaces.

The plunger rod and cylinder tube are ceramic-coated to fight the effects of abrasion and scoring. In certain applications, the ceramic-coated rod and tube can last twice as long as standard stainless components, while extending packing service life up to four times.

2:1 Ratio, 4-1/4" Air Motor, 4-Ball Lower End

6 5 0 4 3 9 - X 4 B

Packings

- 7 – Glass-filled Teflon (upper), virgin Teflon (lower)
- C – UHMW-PE
- F – UHMW-PE/Leather staggered (upper), UHMW-PE (lower)
- R – Teflon/UHMW-PE staggered (upper), virgin Teflon (lower)

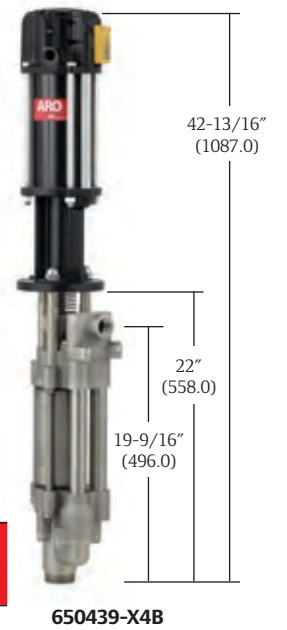

Model	Lower Pump Material	Plunger Material	Air Motor	Stroke in (mm)	Air Inlet	Exhaust Port	Lower Pump Model	Material Inlet	Material Outlet	Weight lb (kg)
650439-X4B	CF8M stainless steel	17-4 stainless steel*	65465-B	6" (152)	1/2" NPT(F)	1-1/4" NPT(F)	67200-X4B	1-1/2" NPT(F) 2" NPT(M)	1" NPT(F)	68.0 (30.8)

*Ceramic coating.

Model	Air Inlet Pressure Range psi (bar)	Fluid Pressure Range psi (bar)	Max Cycles/Minute	Displacement per Cycle cu in (cm³)	Cycles per gal (L)	Flow @ 60 Cycles gpm (L/min)	Noise Level @ 60 psi dBA
650439-X4B	30 – 150 (2.1 – 10.3)	60 – 312 (4.1 – 21.5)	60	82.1 (1345.3)	2.8 (0.74)	21.3 (80.6)	81.8

Accessories

Part Number	Description
650439-X4B	
C28241-810	Air line F/R/L
66101	Wall mount
62274	Air line oil
91790	Muffler
66333-B	Wet Sol
67187-1	Mounting post
61268	Air motor repair kit
637317-X4B	Lower pump repair kit
67139	Portable cart

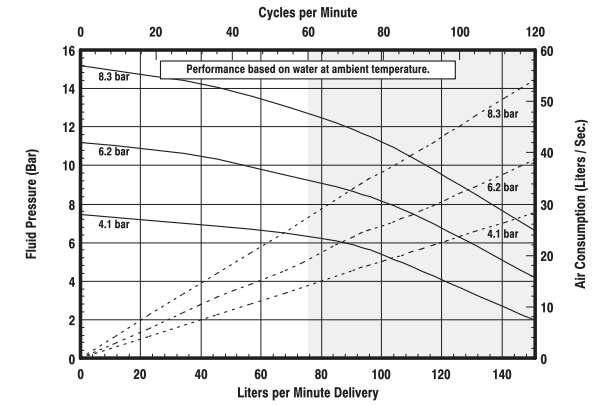
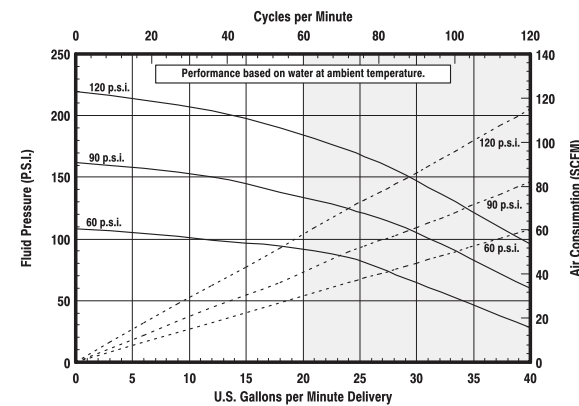

3:1 Ratio, 6" Air Motor, 4-Ball Lower End

6 5 0 6 4 0 - X 4 B

Packings

- 7 – Glass-filled Teflon (upper), virgin Teflon (lower)
- C – UHMW-PE
- F – UHMW-PE/Leather staggered (upper), UHMW-PE (lower)
- P – UHMW-PE/Teflon staggered (upper), UHMW-PE (lower)
- R – Teflon/UHMW-PE (upper), virgin Teflon (lower)

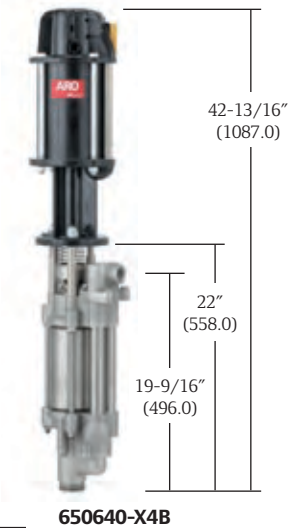

650640-X4B

Model	Lower Pump Material	Plunger Material	Air Motor	Stroke in (mm)	Air Inlet	Exhaust Port	Lower Pump Model	Material Inlet	Material Outlet	Weight lb (kg)
650640-X4B	CF8M stainless steel	17-4 stainless steel*	65665-B	6" (152)	1/2" NPT(F)	1-1/4" NPT(F)	67201-X4B	1-1/2" NPT(F) 2" NPT(M)	1" NPT(F)	73.2 (33.2)

*Ceramic coating.

Accessories

Model	Air Inlet Pressure Range psi (bar)	Fluid Pressure Range psi (bar)	Max Cycles/Minute	Displacement per Cycle cu in (cm ³)	Cycles per gal (L)	Flow @ 60 Cycles/gpm (L/min)	Noise Level @ 60 psi dBA
650640-X4B	30 – 150 (2.1 – 10.3)	90 – 457 (6.2 – 31.5)	60	112.7 (1846.8)	2.05 (0.54)	29.3 (110.8)	84.8 w/ muffler

Part Number	Description
650640-X4B	
C28241-810	Air line F/R/L
66101	Wall mount
62274	Air line oil
91790	Muffler
66333-B	Wet Sol
67187-1	Mounting post
61355	Air motor repair kit
637318-X4B	Lower pump repair kit
67139	Portable cart

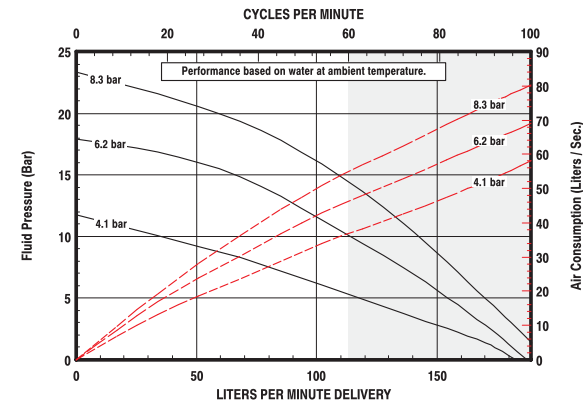
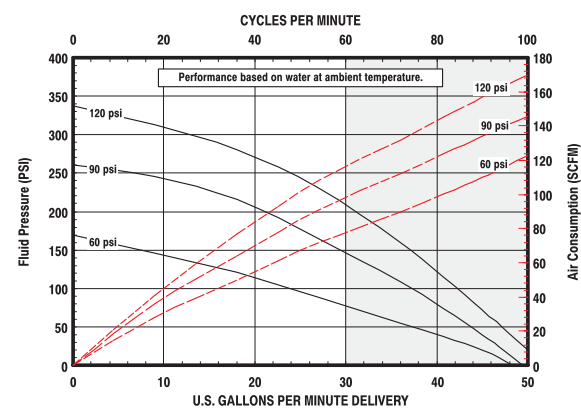

4:1 Ratio, 6" Air Motor, 4-Ball Lower End

6 5 0 6 3 9 - X 4 B

Packings

- 7 – Glass-filled Teflon (upper), virgin Teflon (lower)
- C – UHMW-PE
- F – UHMW-PE/Leather staggered (upper), UHMW-PE (lower)
- P – UHMW-PE/Teflon staggered (upper), UHMW-PE (lower)
- R – Teflon/UHMW-PE staggered (upper), virgin Teflon (lower)

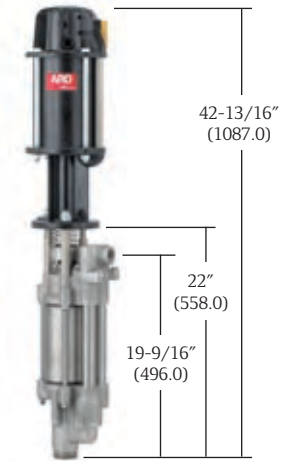

650639-X4B

Model	Lower Pump Material	Plunger Material	Air Motor	Stroke in (mm)	Air Inlet	Exhaust Port	Lower Pump Model	Material Inlet	Material Outlet	Weight lb (kg)
650639-X4B	CF8M stainless steel	17-4 stainless steel*	65665-B	6" (152)	1/2" NPT(F)	1-1/4" NPT(F)	67200-X4B	1-1/2" NPT(F) 2" NPT(M)	1" NPT(F)	71.2 (32.3)

*Ceramic coating.

Accessories

Model	Air Inlet Pressure Range psi (bar)	Fluid Pressure Range psi (bar)	Max Cycles/Minute	Displacement per Cycle cu in (cm ³)	Cycles per gal (L)	Flow @ 60 Cycles/gpm (L/min)	Noise Level @ 60 psi dBA
650639-X4B	30 – 150 (2.1 – 10.3)	120 – 633 (8.3 – 43.7)	60	82.1 (1345.3)	2.8 (0.74)	21.3 (80.6)	84.8 w/ muffler

Part Number	Description
650639-X4B	
C28241-810	Air line F/R/L
66101	Wall mount
62274	Air line oil
91790	Muffler
66333-B	Wet Sol
67187-1	Mounting post
61355	Air motor repair kit
637317-X4B	Lower pump repair kit
67139	Portable cart

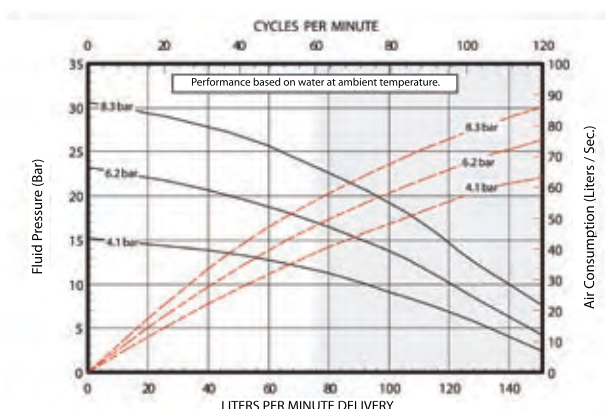
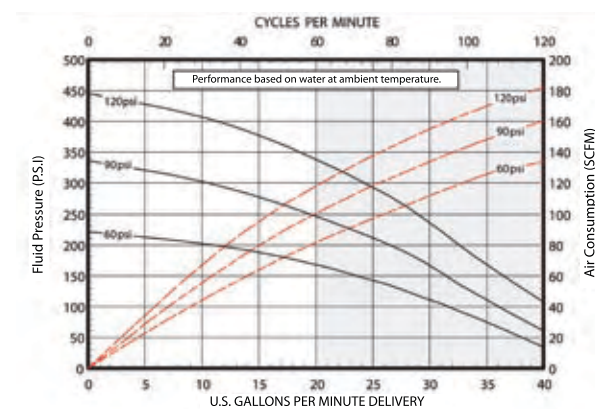

5:1 Ratio, 8" Air Motor, 4-Ball Lower End

6 5 0 8 4 0 - X 4 G - B

Packings

- 7 – Glass-filled Teflon (upper), virgin Teflon (lower)
- C – UHMW-PE
- R – Teflon/UHMW-PE staggered (upper), virgin Teflon (lower)



650840-X4G-B

Model	Lower Pump Material	Plunger Material	Air Motor	Stroke in (mm)	Air Inlet	Exhaust Port	Lower Pump Model	Material Inlet	Material Outlet	Weight lb (kg)
650840-X4G-B	CF8M stainless steel	17-4 stainless steel*	66523-B	6" (152)	3/4" NPT(F)	1-1/4" NPT(F)	67201-X4G	1-1/2" NPT(F) 2" NPT(M)	1" NPT (F)	96.0 (43.5)

*Ceramic coating.

Accessories

Model	Air Inlet Pressure Range psi (bar)	Fluid Pressure Range psi (bar)	Max Cycles/Minute	Displacement per Cycle cu in (cm ³)	Cycles per gal (L)	Flow @ 70 Cycles gpm (L/min)	Noise Level @ 60 psi dBA
650840-X4G-B	30 – 120 (2.1 – 8.3)	150 – 702 (10.3 – 48.4)	70	108.1 (1771.4)	2.1 (0.5)	32.8 (124.0) w/ muffler	89.8

Part Number	Description
650840-X4G-B	
28353	Air line F/R/L
66542	Wall mount
62274	Air line oil
92460	Muffler
66333-B	Wet Sol
67187-1	Mounting post
66614	Air motor repair kit
637318-X4C	Lower pump repair kit
66554-2	Portable cart

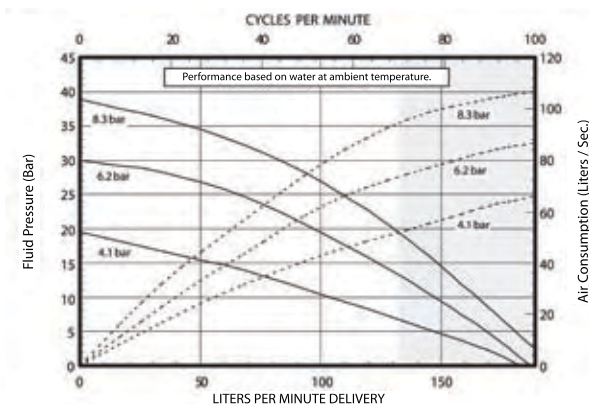
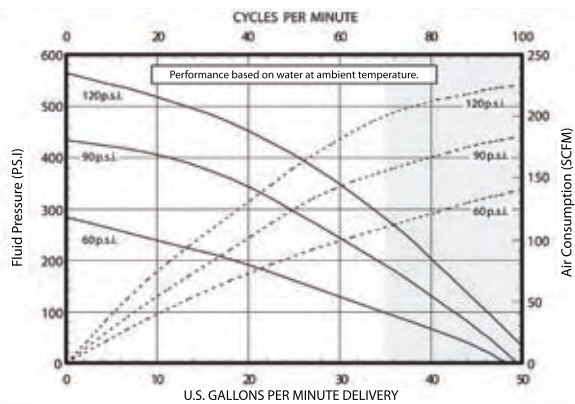

7:1 Ratio, 8" Air Motor, 4-Ball Lower End

6 5 0 8 3 9 - X 4 G - B

Packings

- 7 – Glass-filled Teflon (upper), virgin Teflon (lower)
- C – UHMW-PE
- F – UHMW-PE/Leather staggered (upper), UHMW-PE (lower)
- R – Teflon/UHMW-PE staggered (upper), virgin Teflon (lower)

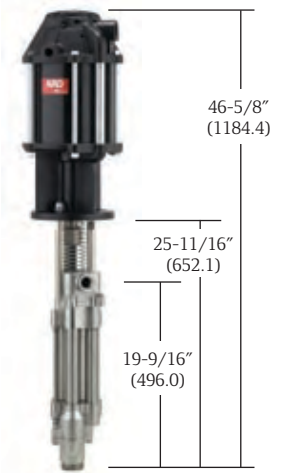

650839-X4G-B

Model	Lower Pump Material	Plunger Material	Air Motor	Stroke in (mm)	Air Inlet	Exhaust Port	Lower Pump Model	Material Inlet	Material Outlet	Weight lb (kg)
650839-X4G-B	CF8M stainless steel	17-4 stainless steel*	66523-B	6" (152)	3/4" NPT(F)	3/4" NPT(F)	67200-X4G	1-1/2" NPT(F) 2" NPT(M)	1" NPT(F)	94.0 (42.6)

*Ceramic coating.

Accessories

Model	Air Inlet Pressure Range psi (bar)	Fluid Pressure Range psi (bar)	Max Cycles/Minute	Displacement per Cycle cu in (cm ³)	Cycles per gal (L)	Flow @ 70 Cycles gpm (L/min)	Noise Level @ 60 psi dBA
650839-X4G-B	30 – 120 (2.1 – 8.3)	210 – 1,009 (14.5 – 69.6)	70	77.5 (1269.9)	2.9 (0.7)	23.5 (88.8) w/ muffler	89.8

Model	Overall height in (mm)	Height to outlet in (mm)	Height to base in (mm)	Height to base Description
650839-X4G-B	46-5/8" (1184.4)	19-9/16" (496.0)	25-11/16" (652.1)	To base of motor

Part Number	Description
650839-X4G-B	
28353	Air line F/R/L
66542	Wall mount
62274	Air line oil
92460	Muffler
66333-B	Wet Sol
67187-1	Mounting post
66614	Air motor repair kit
637317-X4G	Lower pump repair kit
66554-2	Portable cart

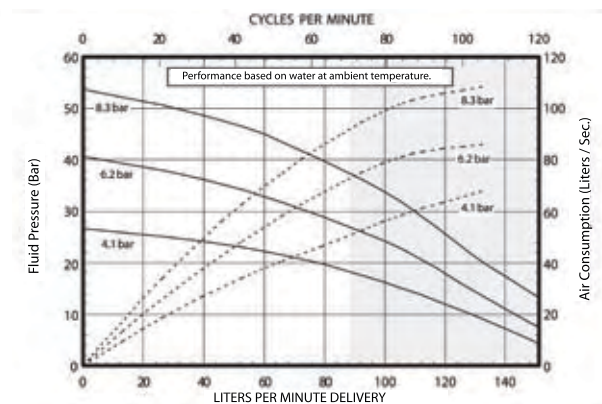
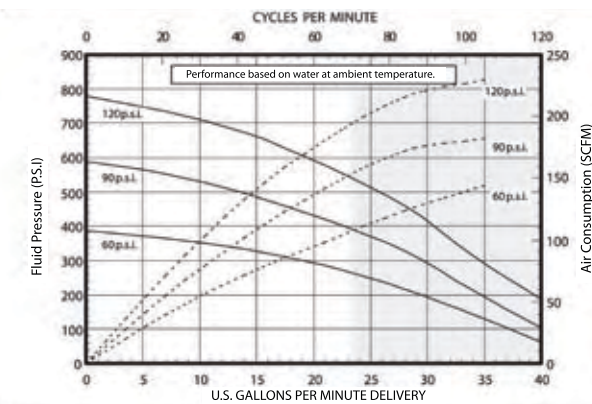

Chop-Check Pumps



ARO chop-check (extrusion) pumps are most frequently utilized in the most difficult of applications. They are designed to move medium-to-high viscosity fluids (15,000 to 1,000,000+ cPs) such as caulking, heavy lubricants, mastics, sealers, and inks.

Chop-check pumps make up the heart of our piston pump line. Customers can select pumps to draw material from 5-gallon pails, 55-gallon drums, and bulk tanks. Ratios range from 12:1 to 65:1, with delivery rates up to 12.2 gpm (46.3 L/min).

Excessive cycling can be a problem for piston pumps. The heat generated by fast or excessive cycling can cause packings to fail prematurely.

ARO has designed its pumps' features to avoid this problem. Maximum displacement in the chop-check line is 40 cu in (662 cm³). High displacement means the pump can cycle slowly and still meet application requirements. Air motors with a 6" stroke length mean more fluid delivery per cycle over competitive models.

ARO Chop-Check Pump Features



Many design features of ARO chop-check lower ends lead to the same goal: extended pump service life even when pumping abrasive, viscous materials.

Packing Options Maximize Compatibility

Throat and piston packing options allow you to match the packing with the fluid being pumped. Ultra-high molecular weight polyethylene (UHMW-PE) helps withstand the abrasive demands of inks, mastics, and other fluids. Teflon is for use with corrosive fluids.

Abrasion-Resistant Components

Moving an abrasive fluid? ARO chop-check pumps feature plunger rods that are hard chrome-plated or made of hardened stainless steel. The result: components that resist the scoring caused by pumping abrasive fluids.

High-Displacement Operation

The best way to extend a pump's service life is to slow down the operating speed. ARO offers high-displacement chop-check lower ends with a 6" stroke. This combination delivers more fluid per stroke, allowing the pump to operate at a slower cycle rate.

High-Flow Inlet Primer Valve

High-flow valve design assists in drawing material into the pump during the priming process. Fluid gets to the packings as soon as possible, helping to prevent packing failure. Inlet design also allows pumps to be floor-stand mounted for bulk and ram-mounted for high viscosity pumping.

12:1 Ratio, 4-1/4" Air Motor, Chop-Check Lower End

6 5 0 4 9 1 - X 4 3 - B

Packings

- 3 - Glass-filled Teflon
- C - UHMW-PE
- G - UHMW-PE/Leather staggered
- P - UHMW-PE/Teflon staggered (upper), UHMW-PE (lower)
- R - Teflon/UHMW-PE staggered (upper), glass-filled Teflon (lower)

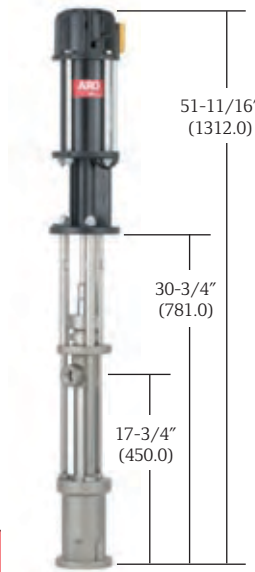

650491-X43-B

Model	Lower Pump Material	Plunger Material	Air Motor	Stroke in (mm)	Air Inlet	Exhaust Port	Lower Pump Model	Material Inlet	Material Outlet	Weight lb (kg)
650491-X43-B	Carbon steel*	17-4 stainless steel**	65465-B	6" (152)	1/2" NPT(F)	1-1/4" NPT(F)	66243-X43-B	Flange mount	1" NPT(F)	64.0 (29.0)

*Nickel-plated.
**Hard chrome-plated.

Accessories

Model	Air Inlet Pressure Range psi (bar)	Fluid Pressure Range psi (bar)	Max Cycles/Minute	Displacement per Cycle cu in (cm ³)	Cycles per gal (L)	Flow @ 60 Cycles gpm (L/min)	Noise Level @ 60 psi dBA
650491-X43-B	0 - 150 (0 - 10.3)	0 - 2,085 (0 - 143.8)	60	12.5 (204.8)	18.5 (4.8)	3.2 (12.3)	80 w/ muffler

Part Number	Description
650491-X43-B	
C28241-810	Air line F/R/L
62274	Air line oil
91790	Air motor muffler
66333-B	Wet Sol
65138	Floor mount
61268	Air motor repair kit
637071-X43-B	Lower pump repair kit

Reference mounting footprint "A" for related rams and accessories.

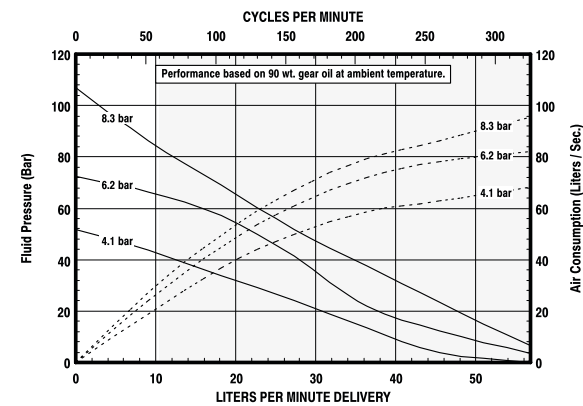
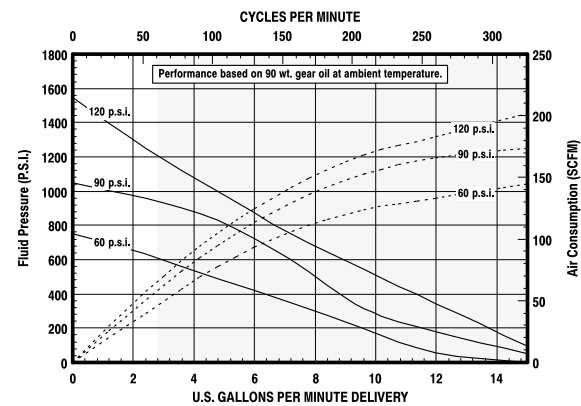

13:1 Ratio, 8" Air Motor, Chop-Check Lower End

6 5 0 8 7 1 - X X E - C

Packings/Springs

- C4 - UHMW-PE (upper and lower), multiple-wave spring
- F4 - UHMW-PE/Leather staggered (upper), UHMW-PE (lower), multiple-wave spring
- J3 - Polyurethane (upper), UHMW-PE (lower), no spring
- P4 - UHMW-PE/Glass-filled Teflon staggered (upper), UHMW-PE (lower), multiple-wave spring
- R4 - Glass-filled Teflon/UHMW-PE staggered (upper), glass-filled Teflon (lower), multiple-wave spring

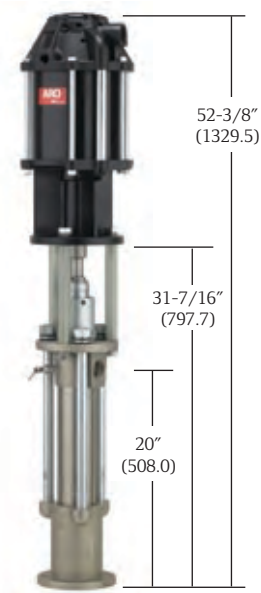

650871-XXE-C

Model	Lower Pump Material	Plunger Material	Air Motor	Stroke in (mm)	Air Inlet	Exhaust Port	Lower Pump Model	Material Inlet	Material Outlet	Weight lb (kg)
650871-XXE-C	Carbon steel*	Carbon steel**	66523-B	6" (152)	3/4" NPT(F)	1-1/4" NPT(F)	66236-XXE-B	Flange mount	1-1/2" NPT(F)	125.5 (56.9)

*Nickel-plated.
**Hard chrome-plated.

Accessories

Model	Air Inlet Pressure Range psi (bar)	Fluid Pressure Range psi (bar)	Max Cycles/Minute	Displacement per Cycle cu in (cm ³)	Cycles per gal (L)	Flow @ 70 Cycles gpm (L/min)	Noise Level @ 60 psi dBA
650871-XXE-C	30 - 120 (2.1 - 8.3)	390 - 1,900 (26.9 - 131.0)	70	40.4 (662.0)	5.7 (1.5)	12.2 (46.3)	89.8 w/ muffler

Part Number	Description
650871-XXE-C	
28353	Air line F/R/L
62274	Air line oil
92460	Air motor muffler
66333-B	Wet Sol
65139	Floor mount
66614	Air motor repair kit
637128-XX4-B	Lower pump repair kit

Reference mounting footprint "B" for related rams and accessories.

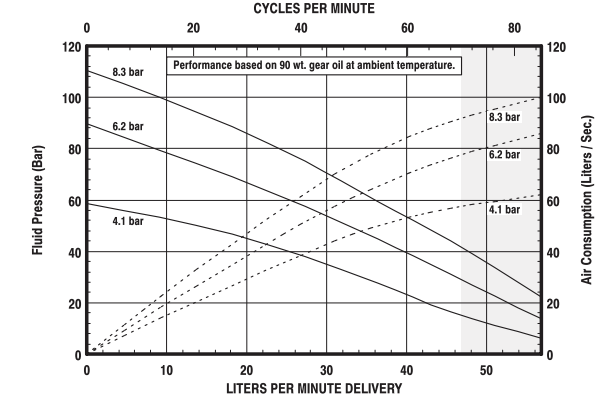
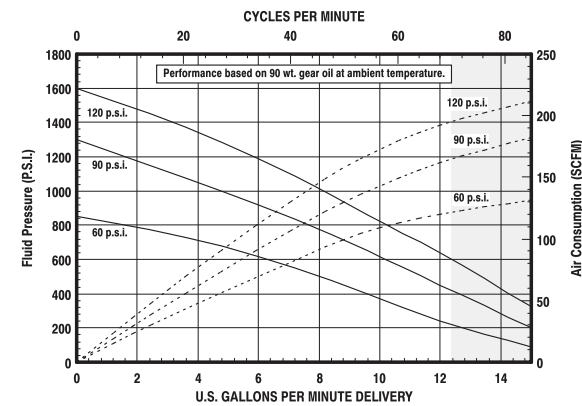

20:1 Ratio, 10" Air Motor, Chop-Check Lower End

6 5 0 8 7 5 - X X E - C

Packings/Springs

- C4 - UHMW-PE (upper and lower), multiple-wave spring
- F4 - UHMW-PE/Leather staggered (upper), UHMW-PE (lower), multiple-wave spring
- J3 - Polyurethane (upper), UHMW-PE (lower), no spring
- P4 - UHMW-PE/Teflon staggered (upper), UHMW-PE (lower), multiple-wave spring
- R4 - Teflon/UHMW-PE staggered (upper), Teflon (lower), multiple wave-spring

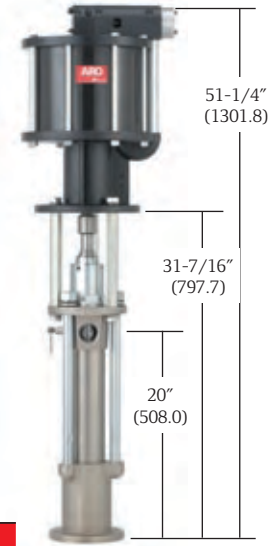

650875-XXE-C

Model	Lower Pump Material	Plunger Material	Air Motor	Stroke in (mm)	Air Inlet	Exhaust Port	Lower Pump Model	Material Inlet	Material Outlet	Weight lb (kg)
650875-XXE-C	Carbon steel	Carbon steel*	66651-B	6" (152)	3/4" NPT(F)	1-1/4" NPT(F)	66236-XXE-B	Bolted flange	1-1/2" NPT(F)	144.0 (65.3)

*Hard chrome-plated.

Accessories

Part Number	Description
650875-XXE-C	
28353	Air line F/R/L
62274	Air line oil
66718	Air motor muffler
66333-B	Wet Sol
65139	Floor mount
637110	Air motor repair kit
637128-XX4-B	Lower pump repair kit

Reference mounting footprint "B" for related rams and accessories.

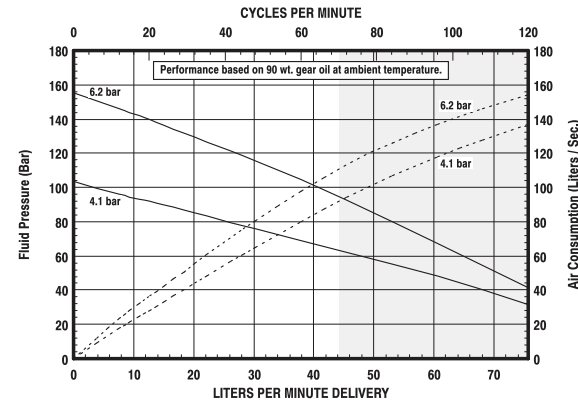
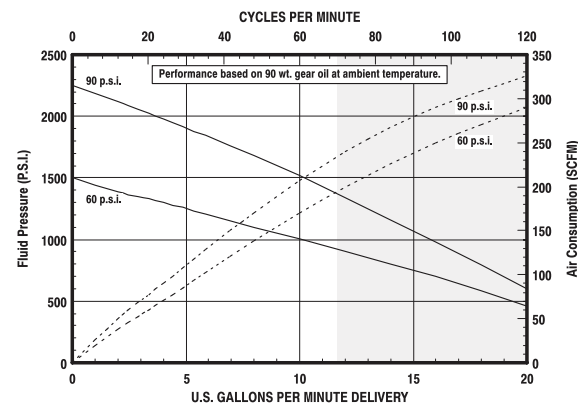

22:1 Ratio, 3" Air Motor, Chop-Check Lower End

N M 2 3 2 2 E - X X - P 4 X

Spacer lengths

- 11 - Standard
- 71 - Extended

Packings/Plungers

- P43 - UHMW-PE/Teflon staggered (upper), UHMW-PE (lower) with standard plunger
- P48 - UHMW-PE/Teflon staggered (upper), UHMW-PE (lower) with alternate piston*

*Note: better for fluids containing filler materials.

Model	A in (mm)	B in (mm)	C in (mm)
NM2322E-11-P4X	33-23/32" (856.1)	24-15/32" (620.8)	14-3/16" (360.5)
NM2322E-71-P4X	42-5/8" (1082.6)	33-11/32" (846.9)	14-3/16" (360.5)
NM2322F-11-P4X	33-23/32" (856.1)	24-15/32" (620.8)	14-3/16" (360.5)
NM2322F-71-P4X	42-5/8" (1082.6)	33-11/32" (846.9)	14-3/16" (360.5)

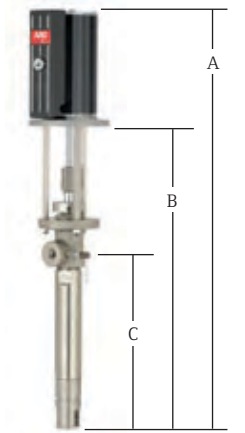

NM2322E-XX-P4X

Available Models	Lower Pump Material	Plunger Material	Air Motor	Stroke in (mm)	Air Inlet	Exhaust Port	Lower Pump Model	Lower Pump Repair Kit	Material Inlet	Material Outlet	Weight lb (kg)
NM2322E-11-P43	316 stainless	17-4 stainless*	66915	3" (76)	1/4" NPT(F)	-	67100-P43	637290-P43	Follower plate-mounted	1/2" NPT(F)	29.0 (13.2)
NM2322E-11-P48	316 stainless	17-4 stainless*	66915	3" (76)	1/4" NPT(F)	-	67100-P48	637290-P48	Follower plate-mounted	1/2" NPT(F)	29.0 (13.2)
NM2322E-71-P43	316 stainless	17-4 stainless*	66915	3" (76)	1/4" NPT(F)	-	67100-P43	637290-P43	Follower plate-mounted	1/2" NPT(F)	33.0 (15.0)

*Hard chrome-plated.

Accessories

Model	Air Inlet Pressure Range psi (bar)	Fluid Pressure Range psi (bar)	Max Cycles/Minute	Displacement per Cycle cu in (cm ³)	Cycles per gal (L)	Max Working Flow gpm (L/min)	Noise Level @ 100 psi dBA
NM2322E-XX-P4X	0 - 150 (0 - 10.3)	0 - 3,300 (0 - 277.6)	120	1.9 (31.1)	121.6 (32.1)	0.99 (3.7)	85

Part Number	Description
NM2322E-XX-P4X	
62274	Air line oil
66333-B	Wet Sol
637316	Air motor repair kit
P29122-600	Piggyback F/R

Reference mounting footprint "C" for related rams and accessories.

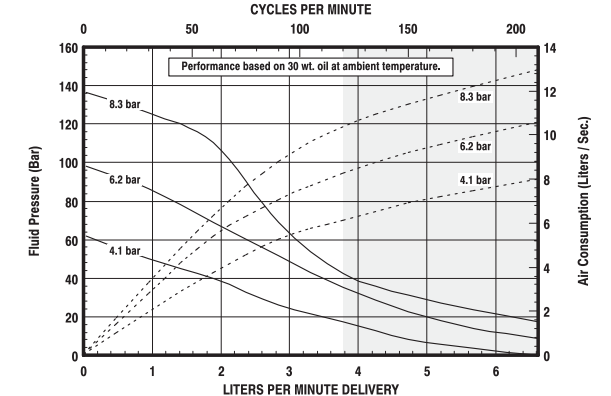
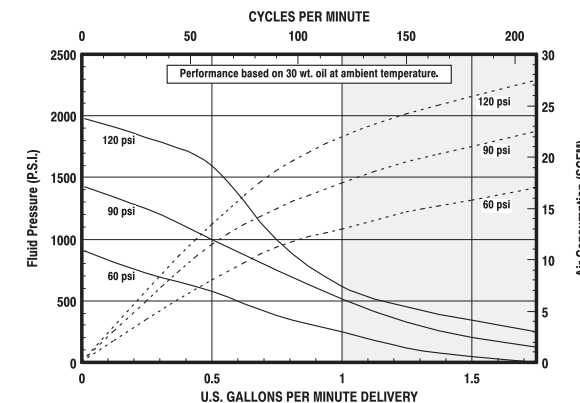

22:1 Ratio, 3" Air Motor, Chop-Check Lower End

N M 2 3 2 2 F - X X - P 4 X

Spacer lengths

11 - Standard
71 - Extended

Packings/Plungers

P43 - UHMW-PE/Teflon staggered (upper),
UHMW-PE (lower) with standard plunger
P48 - UHMW-PE/Teflon staggered (upper),
UHMW-PE (lower) with alternate piston*

*Note: better for fluids containing filler materials.

Model	A in (mm)	B in (mm)	C in (mm)
NM2322E-11-P4X	33-23/32" (856.1)	24-15/32" (620.8)	14-3/16" (360.5)
NM2322E-71-P4X	42-5/8" (1082.6)	33-11/32" (846.9)	14-3/16" (360.5)
NM2322F-11-P4X	33-23/32" (856.1)	24-15/32" (620.8)	14-3/16" (360.5)
NM2322F-71-P4X	42-5/8" (1082.6)	33-11/32" (846.9)	14-3/16" (360.5)

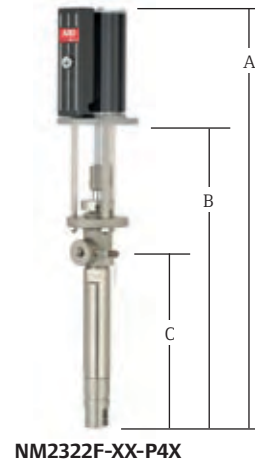

NM2322F-XX-P4X

Available Models	Lower Pump Material	Plunger Material	Air Motor	Stroke in (mm)	Air Inlet	Exhaust Port	Lower Pump Model	Lower Pump Repair Kit	Material Inlet	Material Outlet	Weight lb (kg)
NM2322F-11-P43	316 stainless	17-4 stainless*	66915	3" (76)	1/4" NPT(F)	-	67101-P43	637291-P43	Follower plate-mounted	1/2" NPT(F)	29.0 (13.2)
NM2322F-11-P48	316 stainless	17-4 stainless*	66915	3" (76)	1/4" NPT(F)	-	67101-P48	637291-P48	Follower plate-mounted	1/2" NPT(F)	29.0 (13.2)
NM2322F-71-P48	316 stainless	17-4 stainless*	66915	3" (76)	1/4" NPT(F)	-	67101-P48	637291-P48	Follower plate-mounted	1/2" NPT(F)	33.0 (15.0)

*Hard chrome-plated

Accessories

Model	Air Inlet Pressure Range psi (bar)	Fluid Pressure Range psi (bar)	Max Cycles/Minute	Displacement per Cycle cu in (cm ³)	Cycles per gal (L)	Max Working Flow gpm (L/min)	Noise Level @ 100 psi dBA
NM2322F-XX-P4X	0 - 150 (0 - 10.3)	0 - 3,300 (0 - 277.6)	120	1.9 (31.1)	121.6 (32.1)	.99 (3.7)	85

Part Number	Description
NM2322F-XX-P4X	
62274	Air line oil
66333-B	Wet Sol
637316	Air motor repair kit
P29122-600	Piggyback F/R

Reference mounting footprint "D" for related rams and accessories.

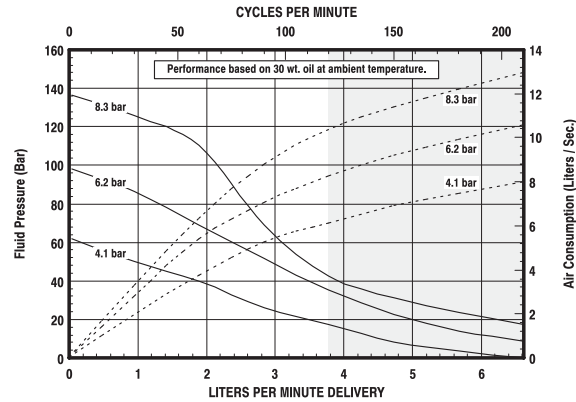
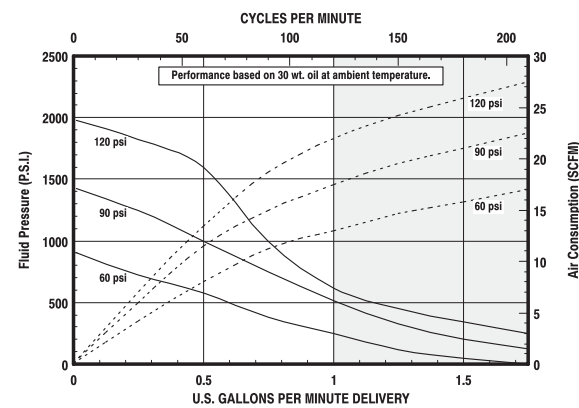

23:1 Ratio, 4-1/4" Air Motor, Chop-Check Lower End

6 5 0 4 9 2 - X 4 3 - B

Packings

3 - Glass-filled Teflon (upper and lower)
C - UHMW-PE (upper and lower)
G - UHMW-PE/Leather staggered (upper and lower)
P - UHMW-PE/Teflon staggered (upper), UHMW-PE (lower)
R - Teflon/UHMW-PE staggered (upper), Teflon (lower)

Model	Lower Pump Material	Plunger Material	Air Motor	Stroke in (mm)	Air Inlet	Exhaust Port	Lower Pump Model	Material Inlet	Material Outlet	Weight lb (kg)
650492-X43-B	Carbon steel*	17-4 stainless**	65465-B	6" (152)	1/2" NPT(F)	1-1/4" NPT(F)	66266-X43-B	Bolted flange	1" NPT(F)	63.7 (28.9)

*Nickel-plated.

**Hard chrome-plated.

Model	Air Inlet Pressure Range psi (bar)	Fluid Pressure Range psi (bar)	Max Cycles/Minute	Displacement per Cycle cu in (cm ³)	Cycles per gal (L)	Flow @ 60 Cycles gpm (L/min)	Noise Level @ 60 psi dBA
650492-X43-B	0 - 150 (0 - 10.3)	0 - 3,690 (0 - 254.5)	60	6.9 (113.0)	33.1 (8.8)	1.8 (6.9)	80

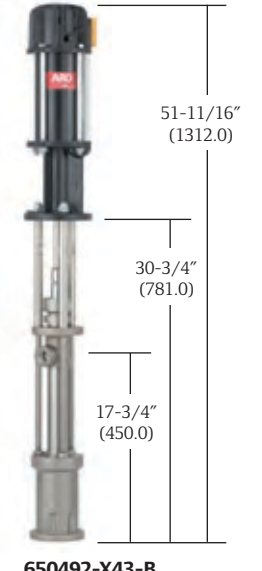

650492-X43-B

Accessories

Part Number	Description
650492-X43-B	
C28241-810	Air line F/R/L
62274	Air line oil
91790	Air motor muffler
66333-B	Wet Sol
65138	Floor mount
61268	Air motor repair kit
637074-X43-B	Lower pump repair kit

Reference mounting footprint "A" for related rams and accessories.

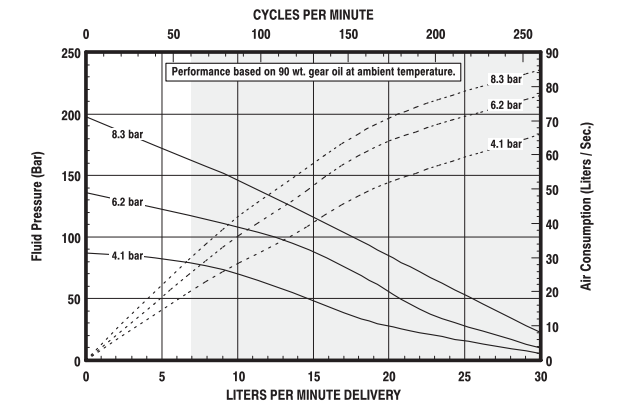
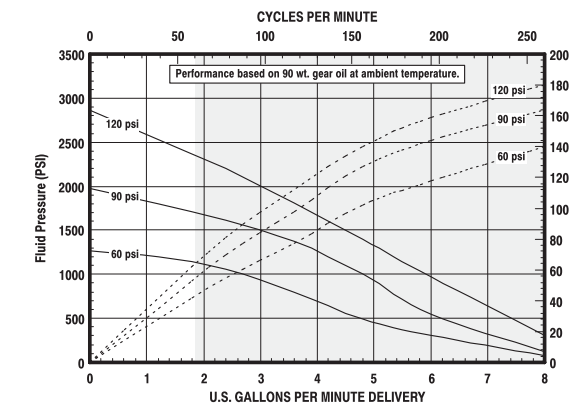

23:1 Ratio, 6" Air Motor, Chop-Check Lower End

6 5 0 6 9 1 - X 4 3 - B

Packings

- 3 – Glass-filled Teflon (upper and lower)
- C – UHMW-PE (upper and lower)
- G – UHMW-PE/Leather staggered (upper and lower)
- P – UHMW-PE/Teflon staggered (upper), UHMW-PE (lower)
- R – Teflon/UHMW-PE staggered (upper), glass-filled Teflon (lower)

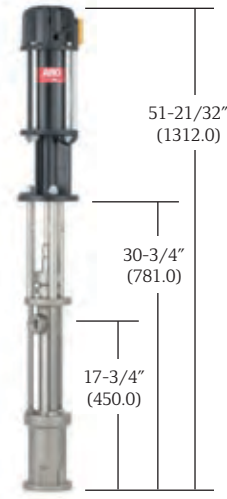

650691-X43-B

Model	Lower Pump Material	Plunger Material	Air Motor	Stroke in (mm)	Air Inlet	Exhaust Port	Lower Pump Model	Material Inlet	Material Outlet	Weight lb (kg)
650691-X43-B	Carbon steel*	17-4 stainless steel**	65665-B	6" (152)	1/2" NPT(F)	1-1/4" NPT(F)	66243-X43-B	Bolted flange	1" NPT(F)	67.0 (30.4)

*Nickel-plated.
**Hard chrome-plated.

Accessories

Model	Air Inlet Pressure Range psi (bar)	Fluid Pressure Range psi (bar)	Max Cycles/Minute	Displacement per Cycle cu in (cm ³)	Cycles per gal (L)	Flow @ 60 Cycles gpm (L/min)	Noise Level @ 60 psi dBA
650691-X43-B	0 – 150 (0 – 10.3)	0 – 4,215 (0 – 290.7)	60	12.5 (204.8)	18.5 (4.8)	3.2 (12.3)	83.0 w/ muffler

Part Number	Description
650691-X43-B	
C28241-810	Air line F/R/L
62274	Air line oil
91790	Air motor muffler
66333-B	Wet Sol
65138	Floor mount
61355	Air motor repair kit
637071-X43-B	Lower pump repair kit

Reference mounting footprint "A" for related rams and accessories.

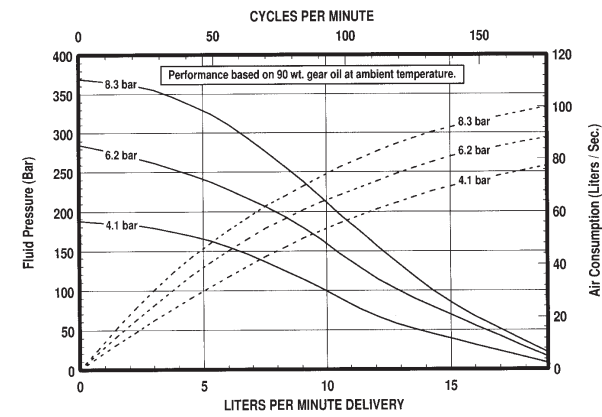
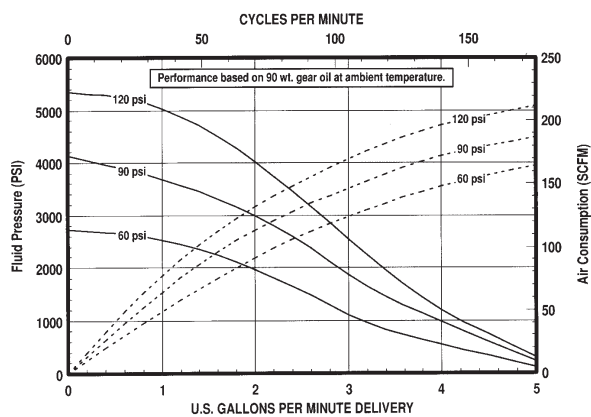

28:1 Ratio, 8" Air Motor, Chop-Check Lower End

6 5 0 8 8 8 - X X D

Packings

- C – UHMW-PE
- J – Polyurethane (upper), UHMW-PE (lower)

Springs

- 3 – No spring
- 4 – Multiple-wave spring

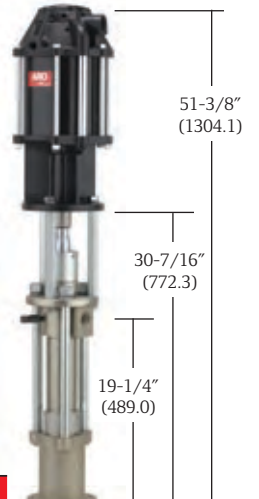

650888-XXX

Available Models	Lower Pump Material	Plunger Material	Air Motor	Stroke in (mm)	Air Inlet	Exhaust Port	Lower Pump Model	Lower Pump Repair Kit	Material Inlet	Material Outlet	Weight lb (kg)
650888-C4D	Carbon steel*	17-4 stainless steel**	66523-B	6" (152)	3/4" NPT(F)	1-1/4" NPT(F)	67300-C4D	637348-C4D	Bolted flange	1-1/4" NPT(F)	140.0 (63.5)
650888-J3D	Carbon steel*	17-4 stainless steel**	66523-B	6" (152)	3/4" NPT(F)	1-1/4" NPT(F)	67300-J3D	637348-J3D	Bolted flange	1-1/4" NPT(F)	140.0 (63.5)

*Nickel-plated.
**Hard chrome-plated.

Model	Air Inlet Pressure Range psi (bar)	Fluid Pressure Range psi (bar)	Max Cycles/Minute	Displacement per Cycle cu in (cm ³)	Cycles per gal (L)	Flow @ 70 Cycles gpm (L/min)	Noise Level @ 60 psi dBA
650888-XXX	30 – 120 (2.1 – 8.3)	840 – 3,360 (57.9 – 231.7)	70	20.0 (327.7)	11.55 (3.0)	6.0 (22.7)	89.8 w/ muffler

Accessories

Part Number	Description
650888-XXX	
28353	Air line F/R/L
62274	Air line oil
92460	Air motor muffler
66333-B	Wet Sol
65139	Floor mount
66614	Air motor repair kit
637348-XXX	Lower pump repair kit

Reference mounting footprint "B" for related rams and accessories.

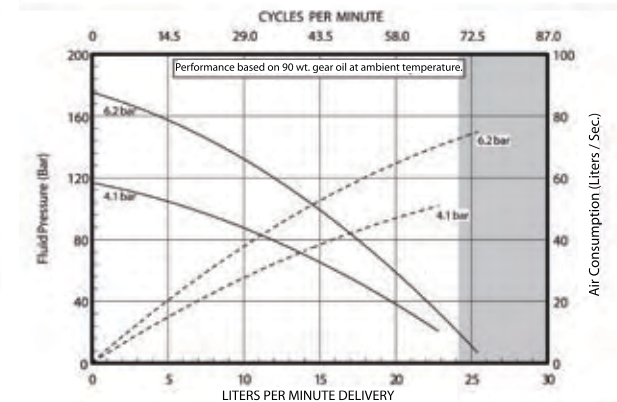
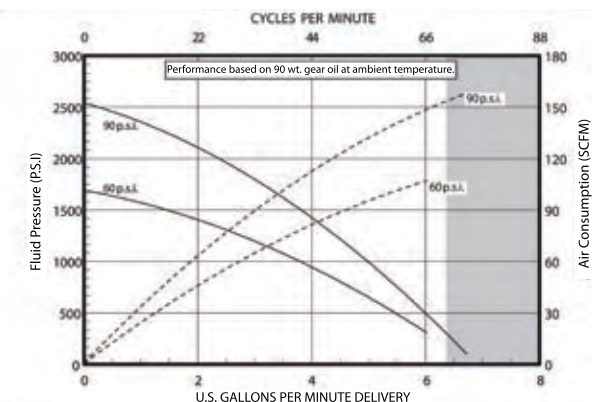

30:1 Ratio, 12" Air Motor, Chop-Check Lower End

6 5 0 9 7 1 - X X E - C

Packings/Springs

- 34 - Glass-filled Teflon, multiple-wave spring
- C4 - UHMW-PE, multiple-wave spring
- F4 - UHMW-PE/Leather staggered (upper), UHMW-PE (lower), multiple-wave spring
- J3 - Polyurethane (upper), UHMW-PE (lower), no spring
- P4 - UHMW-PE/Teflon staggered (upper), UHMW-PE (lower), multiple-wave spring
- R4 - Teflon/UHMW-PE staggered (upper), glass-filled Teflon (lower), multiple-wave spring

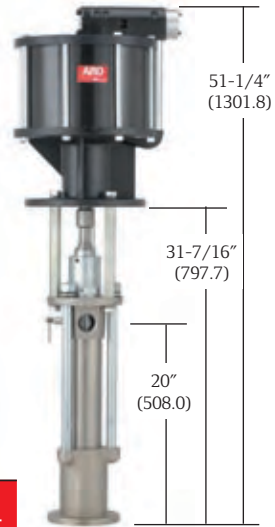

650971-XXE-C

Model	Lower Pump Material	Plunger Material	Air Motor	Stroke in (mm)	Air Inlet	Exhaust Port	Lower Pump Model	Material Inlet	Material Outlet	Weight lb (kg)
650971-XXE-C	Carbon steel*	Carbon steel**	66506-B	6" (152)	3/4" NPT(F)	1-1/4" NPT(F)	66236-XXE-B	Bolted flange	1-1/2" NPT(F)	140.0 (63.5)

*Nickel-plated.
**Hard chrome-plated.

Model	Air Inlet Pressure Range psi (bar)	Fluid Pressure Range psi (bar)	Max Cycles/Minute	Displacement per Cycle cu in (cm ³)	Cycles per gal (L)	Flow @ 70 Cycles/gpm (L/min)	Noise Level @ 60 psi dBA
650971-XXE-C	30 - 90 (2.1 - 6.2)	900 - 3,250 (62.1 - 224.1)	70	40.4 (662.0)	5.7 (1.5)	12.2 (46.3)	89.8 w/ muffler

Accessories

Part Number	Description
650971-XXE-C	
28353	Air line F/R/L
62274	Air line oil
66718	Air motor muffler
66333-B	Wet Sol
65139	Floor mount
637112	Air motor repair kit
637128-XX4-B	Lower pump repair kit

Reference mounting footprint "B" for related rams and accessories.

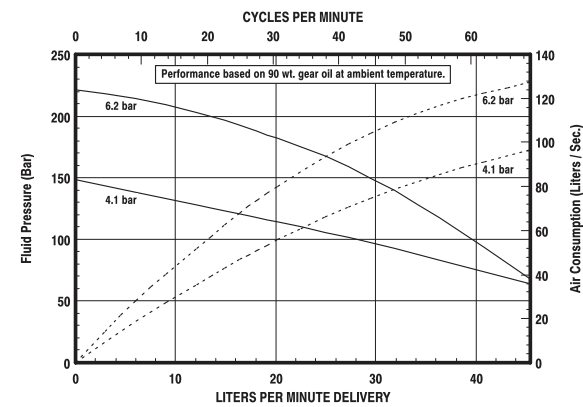
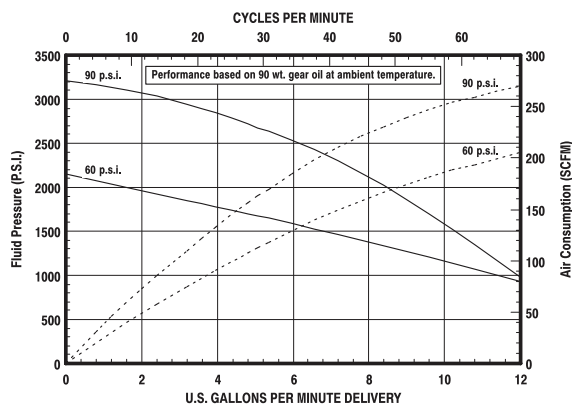

43:1 Ratio, 4-1/4" Air Motor, Chop-Check Lower End

6 7 1 2 X - P 4 3

Spacer lengths

- 0 - Standard length
- 4 - Extended length

Packing/Plunger

- P43 - UHMW-PE/Teflon staggered (upper), UHMW-PE (lower), 17-4 stainless steel

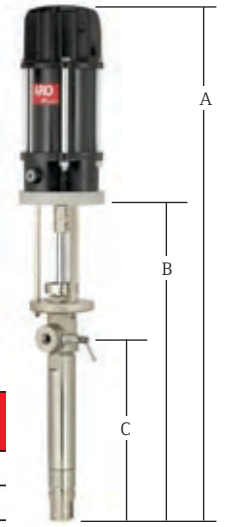

67120-P4X

Model	A in (mm)	B in (mm)	C in (mm)
67120-P43	39-5/8" (1006.6)	24-7/16" (620.8)	14-3/16" (360.5)
67124-P43	48-17/32" (1232.7)	33-11/32" (846.9)	14-3/16" (360.5)
67121-P43	39-5/8" (1006.6)	24-7/16" (620.8)	14-3/16" (360.5)
67125-P43	48-17/32" (1232.7)	33-11/32" (846.9)	14-3/16" (360.5)

Available Models	Lower Pump Material	Plunger Material	Air Motor	Stroke in (mm)	Air Inlet	Exhaust Port	Lower Pump Model	Material Inlet	Material Outlet	Weight lb (kg)
6712X-P43	316 stainless	17-4 stainless steel*	65440	4" (102)	1/2" NPT(F)	1-1/4" NPT(F)	67100-P43	Follower plate-mounted	1/2" NPT(F)	44.0 (20.0)

*Hard chrome-plated.

Model	Air Inlet Pressure Range psi (bar)	Fluid Pressure Range psi (bar)	Max Cycles/Minute	Displacement per Cycle cu in (cm ³)	Cycles per gal (L)	Flow @ 60 Cycles/gpm (L/min)	Noise Level @ 60 psi dBA
6712X-P43	0 - 150 (0 - 10.3)	0 - 6,549 (0 - 451.7)	60	2.8 (45.8)	81.0 (21.7)	0.7 (2.8)	80

Accessories

Part Number	Description
67120-P4X	
C28241-810	Air line F/R/L
62274	Air line oil
91790	Air motor muffler
66333-B	Wet Sol
61268	Air motor repair kit
63729X-P43	Lower pump repair kit

Reference mounting footprint "C" for related rams and accessories.

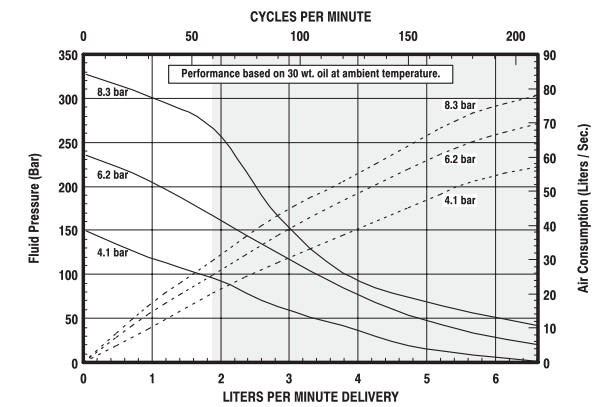
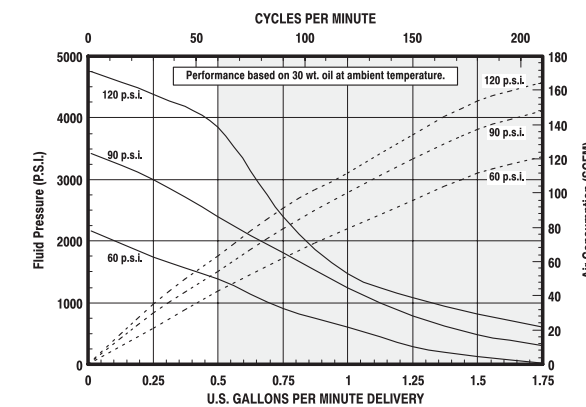

43:1 Ratio, 4-1/4" Air Motor, Chop-Check Lower End

6 7 1 2 X - P 4 3

Spacer lengths

1 - Standard length
5 - Extended length

Packing/Plunger

P43 - UHMW-PE/Teflon staggered (upper),
UHMW-PE (lower), 17-4 stainless steel

Model	A in (mm)	B in (mm)	C in (mm)
67120-P43	39-5/8" (1006.6)	24-7/16" (620.8)	14-3/16" (360.5)
67124-P43	48-17/32" (1232.7)	33-11/32" (846.9)	14-3/16" (360.5)
67121-P43	39-5/8" (1006.6)	24-7/16" (620.8)	14-3/16" (360.5)
67125-P43	48-17/32" (1232.7)	33-11/32" (846.9)	14-3/16" (360.5)

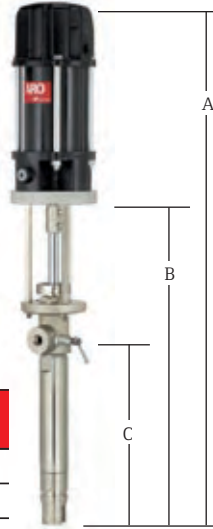

67121-P4X

Available Models	Lower Pump Material	Plunger Material	Air Motor	Stroke in (mm)	Air Inlet	Exhaust Port	Lower Pump Model	Material Inlet	Material Outlet	Weight lb (kg)
6712X-P43	316 stainless	17-4 stainless*	65440	4.0" (101)	1/2" NPT(F)	1-1/4" NPT(F)	637101-P43	Follower plate-mounted	1/2" NPT(F)	44.0 (20.0)

*Hard chrome-plated.

Accessories

Model	Air Inlet Pressure Range psi (bar)	Fluid Pressure Range psi (bar)	Max Cycles/Minute	Displacement per Cycle cu in (cm ³)	Cycles per gal (L)	Flow @ 60 Cycles/gpm (L/min)	Noise Level @ 60 psi dBA
6712X-P43	0 - 150 (0 - 10.3)	0 - 6,549 (0 - 451.7)	60	2.8 (45.8)	81 (21.7)	0.74 (2.8)	80

Part Number	Description
67121-P4X	
C28241-810	Air line F/R/L
62274	Air line oil
91790	Air motor muffler
66333-B	Wet Sol
61268	Air motor repair kit
637291-P43	Lower pump repair kit

Reference mounting footprint "C" for related rams and accessories.

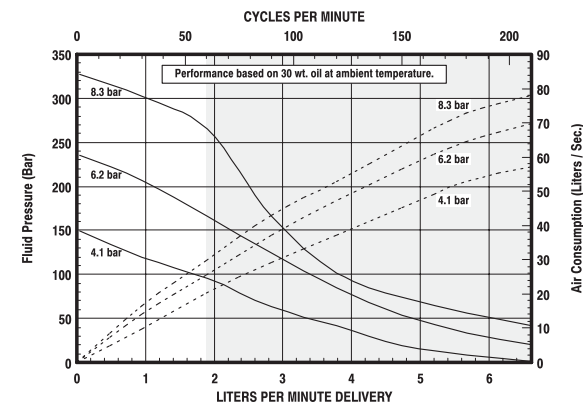
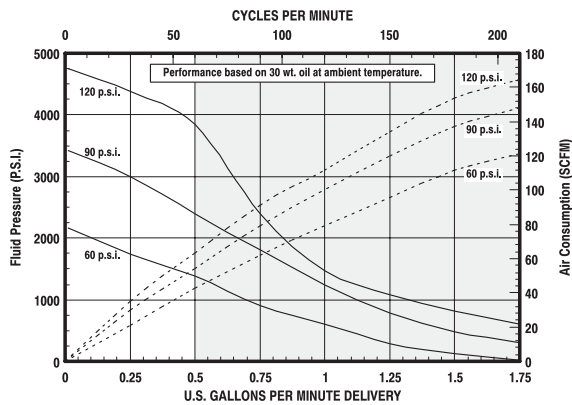

44:1 Ratio, 10" Air Motor, Chop-Check Lower End

6 5 0 8 8 9 - X X D

Packings

C - UHMW-PE
J - Polyurethane (upper), UHMW-PE (lower)

Springs

3 - No spring
4 - Multiple-wave spring

Available Models	Lower Pump Material	Plunger Material	Air Motor	Stroke in (mm)	Air Inlet	Exhaust Port	Lower Pump Model	Material Inlet	Material Outlet	Weight lb (kg)
650889-XXD	Carbon steel*	17-4 stainless steel**	66651-B	6" (152)	3/4" NPT(F)	1-1/4" NPT(F), 3/4" NPT(F)	67300-XXD	Bolted flange	1-1/4" NPT(F)	165.0 (74.8)

*Nickel-plated.

**Hard chrome-plated.

Model	Air Inlet Pressure Range psi (bar)	Fluid Pressure Range psi (bar)	Max Cycles/Minute	Displacement per Cycle cu in (cm ³)	Cycles per gal (L)	Flow @ 70 Cycles/gpm (L/min)	Noise Level @ 60 psi dBA
650889-XXD	30 - 90 (2.1 - 6.2)	1,320 - 3,960 (91.0 - 273.1)	70	20.0 (327.7)	11.5 (3.0)	6.0 (22.9)	84.8 w/ muffler

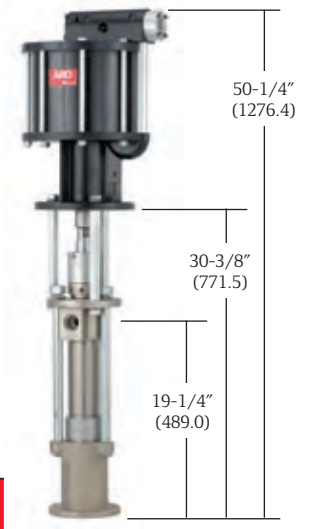

650889-XXD

Accessories

Part Number	Description
650889-XXD	
28353	Air line F/R/L
62274	Air line oil
66718	Air motor muffler
66333-B	Wet Sol
65139	Floor mount
637110	Air motor repair kit
637348-XXD	Lower pump repair kit

Reference mounting footprint "B" for related rams and accessories.

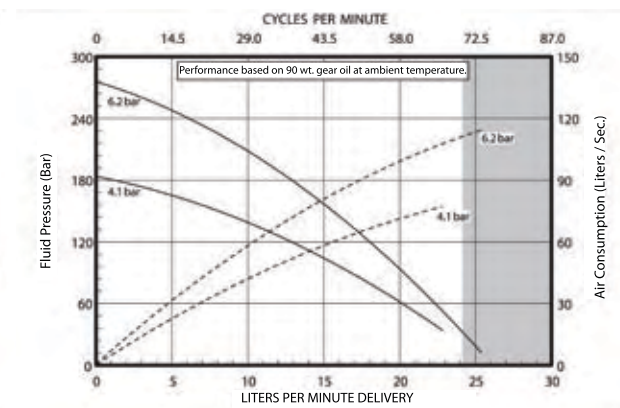
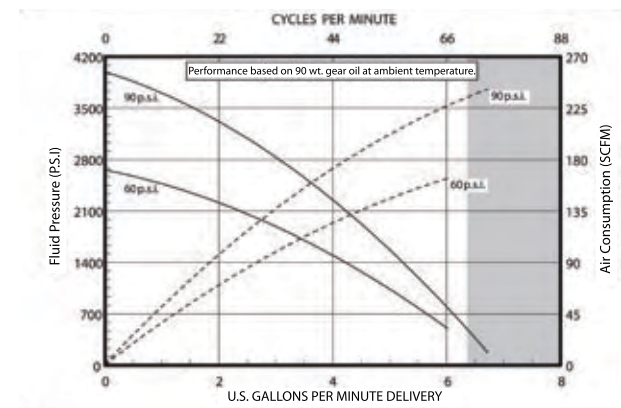

44:1 Ratio, 8" Air Motor, Chop-Check Lower End

6 5 0 8 9 1 - X X D - C

Packings/Springs

- 34 - Glass-filled Teflon, multiple-wave spring
- C4 - UHMW-PE, multiple-wave spring
- CB - UHMW-PE, multiple-wave spring with two-piece spacer
- G4 - UHMW-PE/Leather staggered, multiple-wave spring
- P4 - UHMW-PE/ Teflon staggered (upper), UHMW-PE (lower), multiple-wave spring
- R4 - Teflon/UHMW-PE staggered (upper), glass-filled Teflon (lower), multiple-wave spring

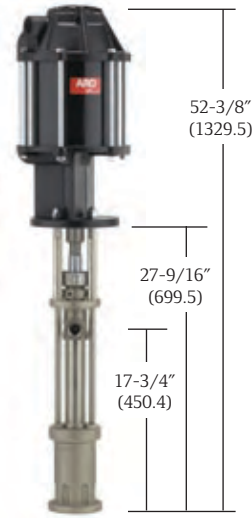

650891-X4D-C

Model	Lower Pump Material	Plunger Material	Air Motor	Stroke in (mm)	Air Inlet	Exhaust Port	Lower Pump Model	Material Inlet	Material Outlet	Weight lb (kg)
650891-XXD-C	Carbon steel*	17-4 stainless steel**	66523-B	6" (152)	3/4" NPT(F)	1-1/4" NPT(F)	66243-XXD-B	Bolted flange	1" NPT(F)	89.0 (40.4)

*Nickel-plated.
**Hard chrome-plated.

Accessories

Model	Air Inlet Pressure Range psi (bar)	Fluid Pressure Range psi (bar)	Max Cycles/Minute	Displacement per Cycle cu in (cm ³)	Cycles per gal (L)	Flow @ 70 Cycles gpm (L/min)	Noise Level @ 60 psi dBA
650891-XXD-C	30 - 120 (2.1 - 8.3)	1,320 - 5,964 (91 - 411.3)	70	12.5 (204.8)	18.5 (4.8)	3.8 (14.3)	89.8 w/ muffler

Part Number	Description
650891-XXD-C	
28353	Air line F/R/L
62274	Air line oil
92460	Air motor muffler
66333-B	Wet Sol
65138	Floor mount
66614	Air motor repair kit
637071-XXX-B	Lower pump repair kit

Reference mounting footprint "A" for related rams and accessories.

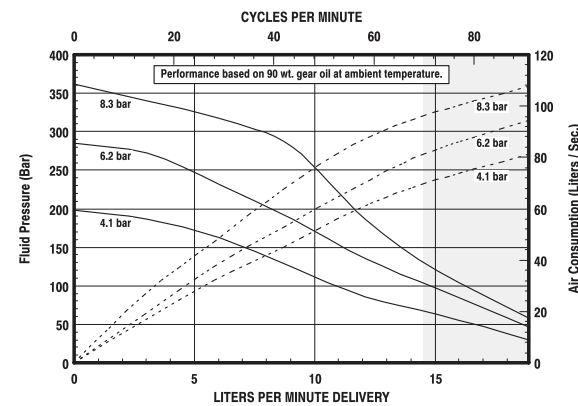
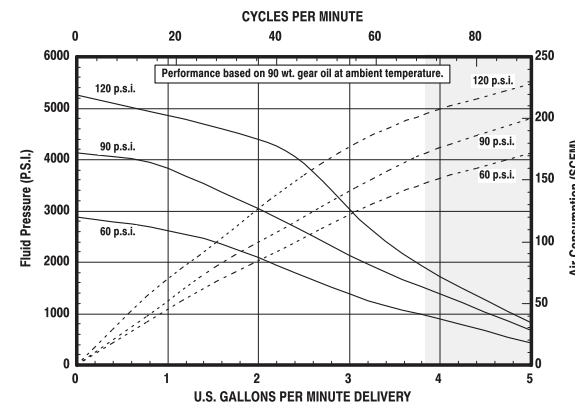

46:1 Ratio, 6" Air Motor, Chop-Check Lower End

6 5 0 6 9 2 - X 4 3 - B

Packings

- 3 - Glass-filled Teflon (upper and lower)
- 4 - Teflon/UHMW-PE staggered (upper), virgin Teflon (lower)
- C - UHMW-PE (upper and lower)
- G - UHMW-PE/Leather staggered
- P - UHMW-PE/Teflon staggered (upper), UHMW-PE (lower)
- R - Teflon/UHMW-PE staggered (upper), Teflon (lower)

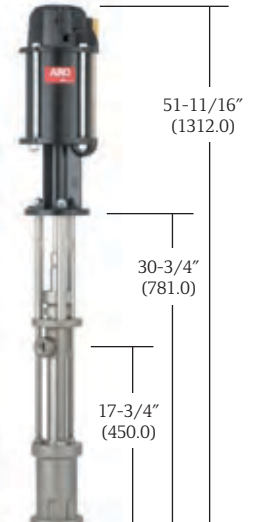

650692-X43-B

Model	Lower Pump Material	Plunger Material	Air Motor	Stroke in (mm)	Air Inlet	Exhaust Port	Lower Pump Model	Material Inlet	Material Outlet	Weight lb (kg)
650692-X43-B	Carbon steel*	17-4 stainless steel**	65665-B	6" (152)	1/2" NPT(F)	1-1/4" NPT(F)	66266-X43-B	Bolted flange	1" NPT(F)	67.0 (30.4)

*Nickel-plated.
**Hard chrome-plated.

Accessories

Model	Air Inlet Pressure Range psi (bar)	Max Fluid Pressure Range psi (bar)	Max Cycles/Minute	Displacement per Cycle cu in (cm ³)	Cycles per gal (L)	Flow @ 60 Cycles gpm (L/min)	Noise Level @ 60 psi dBA
650692-X43-B	0 - 150 (0 - 10.3)	0 - 7,485 (0 - 516.2)	60	6.9 (113)	33.1 (8.8)	1.8 (6.9)	83 w/ muffler

Part Number	Description
650692-X43-B	
C28241-810	Air line F/R/L
62274	Air line oil
91790	Air motor muffler
66333-B	Wet Sol
65138	Floor mount
61355	Air motor repair kit
637074-X43-B	Lower pump repair kit

Reference mounting footprint "A" for related rams and accessories.

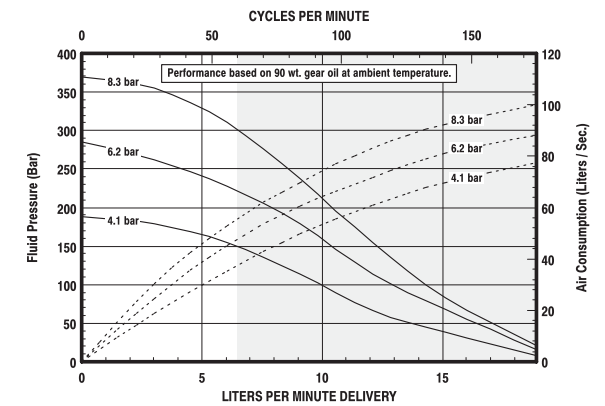
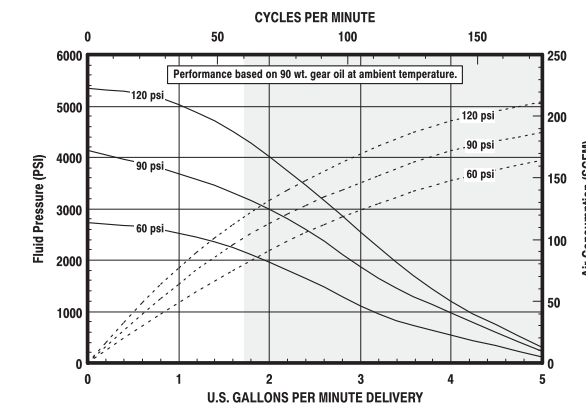

65:1 Ratio, 12" Air Motor, Chop-Check Lower End

6 5 0 9 8 9 - X X D

Packings	Springs
C – UHMW-PE J – Polyurethane (upper), UHMW-PE (lower)	3 – No spring 4 – Multiple-wave spring



650989-XXX

Available Models	Lower Pump Material	Plunger Material	Air Motor	Stroke in (mm)	Air Inlet	Exhaust Port	Lower Pump Model	Material Inlet	Material Outlet	Weight lb (kg)
650989-XXD	Carbon steel*	17-4 stainless steel**	66506-B	6" (152)	3/4" NPT(F)	1-1/4" NPT(F) 3/4" NPT(F)	67300-XXD	1-1/4" NPT(F)	1-1/4" NPS(M)	165.0 (74.8)

*Nickel-plated.
**Hard chrome-plated.

Accessories

Model	Air Inlet Pressure Range psi (bar)	Fluid Pressure Range psi (bar)	Max Cycles/Minute	Displacement per Cycle cu in (cm ³)	Cycles per gal (L)	Flow @ 70 Cycles gpm (L/min)	Noise Level @ 60 psi dBA
650989-XXD	30 – 90 (2.1 – 6.2)	1,950 – 5,850 (134.5 – 403.4)	70	20.0 (327.7)	11.5 (3.0)	6.0 (22.9)	89.8 w/ muffler

Part Number	Description
650989-XXX	
28353	Air line F/R/L
62274	Air line oil
66718	Air motor muffler
66333-B	Wet Sol
65139	Floor mount
637112	Air motor repair kit
637348-XXD	Lower pump repair kit

Reference mounting footprint "B" for related rams and accessories.

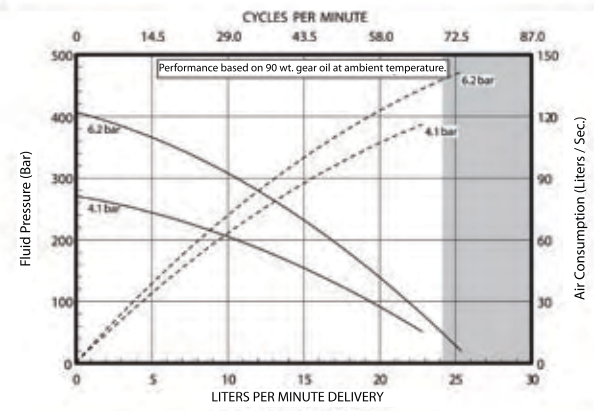
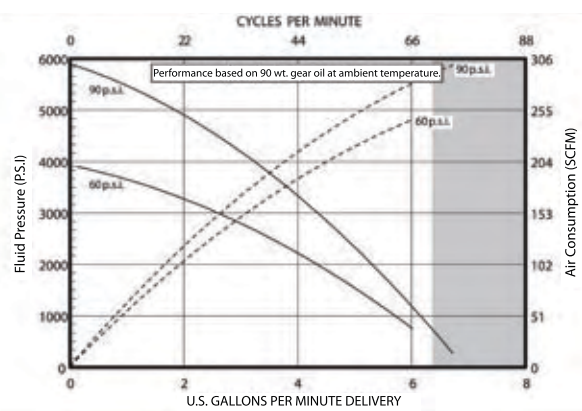

Hydraulic Pumps



No airline to run a piston pump? No problem. Ingersoll Rand / ARO offers a complete line of hydraulically-driven piston pumps. ARO hydraulic powered piston pumps offer the same great quality and reliability as air operated pumps with increased versatility and efficiency.

2-Ball, 4-Ball and chop-check pumps are all available with hydraulic motors. Units can be floor-mounted and draw fluid from nearby tanks, or ram-mounted to work with high viscosity fluids.

The maximum flow of ARO's hydraulic pumps is 17 gpm (64.4 lpm), with maximum outlet pressure at 4320 psi (297.9 bar) fluid pressure.

Where are hydraulic pumps used? Examples include shop areas where little air pressure is available, but have a nearby source of hydraulic power. Another example are pumps placed on a truck bed where the vehicle power take off (PTO) is utilized.

In any case, ARO hydraulic pumps provide the same features as air-driven models: high displacement for long service life and multiple packing options to maximize fluid compatibility.

0.2:1 Ratio, Hydraulic Motor, 4-Ball Lower End

6 5 0 9 5 0 - X 4 B

Packings

- C – UHMW-PE
- P – UHMW-PE/Teflon staggered (upper), UHMW-PE (lower)
- R – Teflon/UHMW-PE staggered (upper), virgin Teflon (lower)

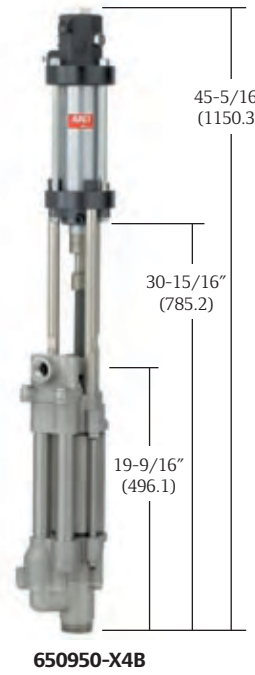

650950-X4B

Model	Lower Pump Material	Plunger Material	Hydraulic Motor	Stroke in (mm)	Hydraulic Inlet	Hydraulic Return	Lower Pump Model	Material Inlet	Material Outlet	Weight lb (kg)
650950-X4B	304 stainless steel*	17-4 stainless steel*	67147	5.7" (144)	3/8" NPT(F)	1/2" NPT(F)	67201-X4B	1-1/2" NPT(F) 2" NPT(M)	1" NPT(F)	72.0 (32.7)

*Ceramic coating.

0.3:1 Ratio, 386 psi (max), 4-Ball

6 5 0 9 4 9 - X 4 B

Packings

- 7 – Teflon
- R – Teflon/UHMW-PE staggered (upper), virgin Teflon (lower)



650949-X4B

Model	Lower Pump Material	Plunger Material	Hydraulic Motor	Stroke in (mm)	Hydraulic Inlet	Hydraulic Return	Lower Pump Model	Material Inlet	Material Outlet	Weight lb (kg)
650949-X4B	304 stainless steel*	17-4 stainless steel*	67147	5.75" (146)	3/8" NPT(F)	1/2" NPT(F)	67200-X4B	1-1/2" NPT(F) 2" NPT(M)	1" NPT(F)	70.0 (31.8)

*Ceramic coating.

Accessories

Part Number	Description
650950-X4B	
61937-1	Wall mount
667187-2	Mounting post
637315	Motor repair kit
637318-X4B	Lower pump repair kit

Model	Hydraulic Inlet Pressure Range psi (bar)	Fluid Pressure Range psi (bar)	Max Cycles/Minute	Displacement per Cycle cu in (cm ³)	Cycles per gal (L)	Flow @ 50 Cycles/Minute	Max Hydraulic Temp Limit
650950-X4B	50 – 1,200 (3.4 – 82.8)	10 – 278 (0.6 – 19.2)	50	103.6 (1,697.6)	2.2 (0.5)	22.4 (84.9)	130° F (54° C)

Accessories

Part Number	Description
650949-X4B	
61937-1	Wall mount
667187-2	Mounting post
637317-X4B	Lower pump repair kit

Model	Hydraulic Inlet Pressure Range psi (bar)	Fluid Pressure Range psi (bar)	Max Cycles/Minute	Displacement per Cycle cu in (cm ³)	Cycles per gal (L)	Flow @ 50 Cycles/Minute	Max Hydraulic Temp Limit
650949-X4B	50 – 1,200 (3.4 – 82.8)	15 – 386 (1.0 – 26.6)	50	78.6 (1288)	2.9 (0.77)	17.0 (64.4)	130° F (54° C)

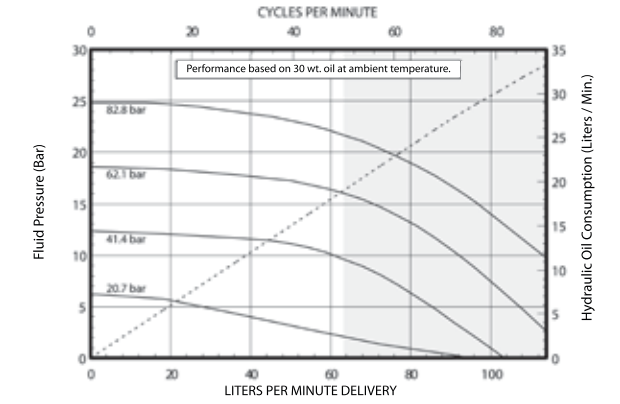
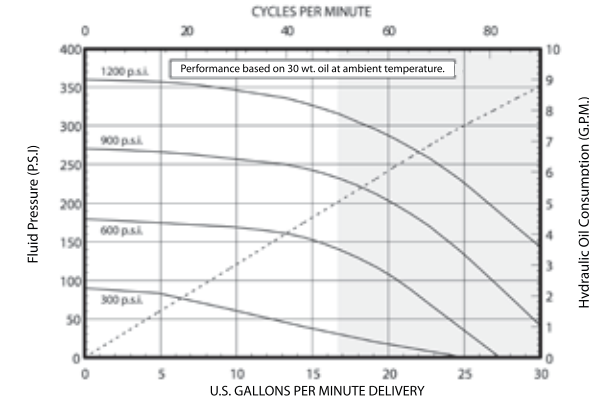
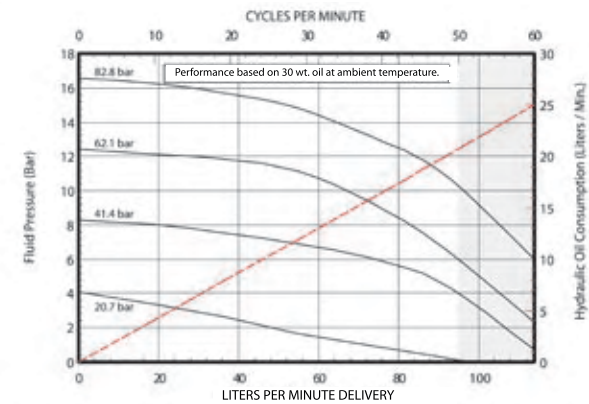
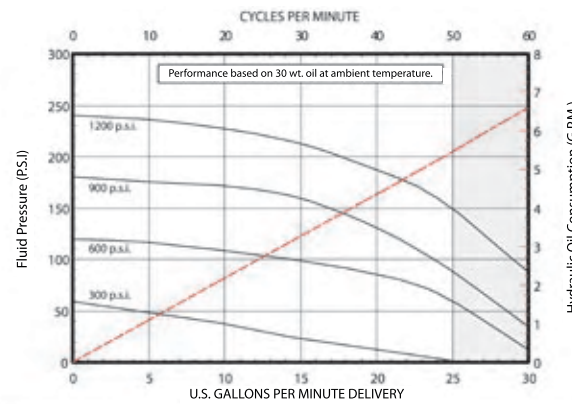

0.58:1 Ratio, 2,040 psi (max), 2-Ball

6 5 0 9 4 3 - X 4 X - B

Packing
3 - Teflon

Plunger
3 - 17-4 Stainless steel (hard chrome-plated)

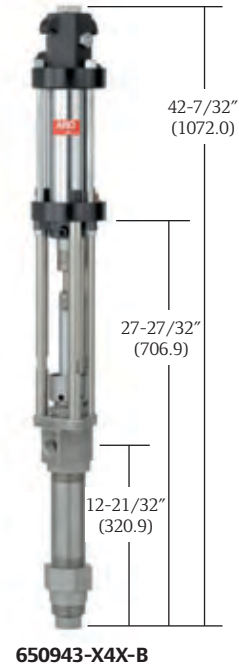

650943-X4X-B

Model	Lower Pump Material	Plunger Material	Hydraulic Motor	Stroke in (mm)	Hydraulic Inlet	Hydraulic Return	Lower Pump Model	Material Inlet	Material Outlet	Weight lb (kg)
650943-X4X-B	304 stainless steel*	17-4 stainless steel*	67147	6" (152)	3/8" NPT(F)	1/2" NPT(F)	66300-X4X	1-1/2" NPT(F) 2" NPT(M)	1" NPT(F)	41.3 (18.7)

*Hard chrome-plated.

0.8:1 Ratio, 4.125" ², 2-Ball

6 5 0 9 4 0 - X X D - B

Packings
C - UHMW-PE
L - Mineral-filled Teflon
P - UHMW-PE/Teflon staggered (upper), UHMW-PE (lower)
R - Teflon/UHMW-PE (upper), Teflon (lower)

Springs
6 - Wave spring
D - Wave spring with alternate seat material

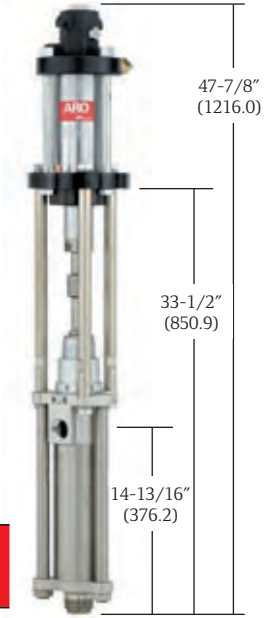

650940-XXD-B

Model	Lower Pump Material	Plunger Material	Hydraulic Motor	Stroke in (mm)	Hydraulic Inlet	Hydraulic Return	Lower Pump Model	Material Inlet	Material Outlet	Weight lb (kg)
650940-XXD-B	CF8M stainless steel*	15-5 stainless steel*	67314	6" (152)	1/2" NPT(F)	3/4" NPT(F)	66941-XXD	2" NPT(M)	1-1/4" NPT(F)	140 (63.5)

*Hard chrome-plated.

Accessories

Model	Hydraulic Inlet Pressure Range psi (bar)	Fluid Pressure Range psi (bar)	Max Cycles/Minute	Displacement per Cycle cu in (cm ³)	Cycles per gal (L)	Flow @ 50 Cycles/Minute	Max Hydraulic Temp Limit
650943-X4X-B	50 - 1,200 (3.4 - 82.8)	85 - 2,054 (0 - 141)	50	14.5 (237.6)	15.9 (4.2)	3.1 (11.9)	130° F (54° C)

Part Number	Description
650943-X4X-B	
67069	Wall mount
66333-B	Wet Sol
637305-X43	Lower pump repair kit

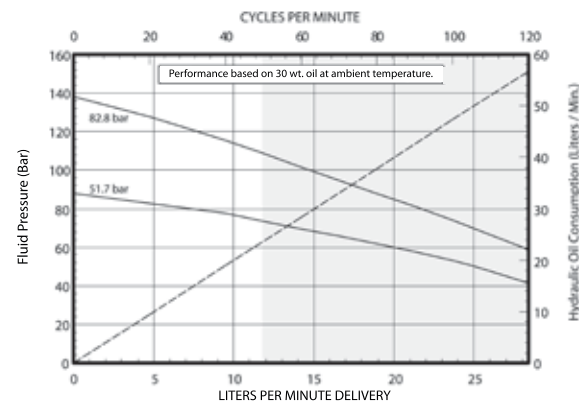
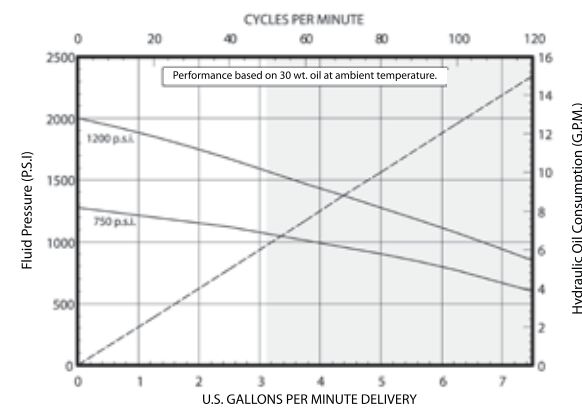

Model	Hydraulic Inlet Pressure Range psi (bar)	Fluid Pressure Range psi (bar)	Max Cycles/Minute	Displacement per Cycle cu in (cm ³)	Cycles per gal (L)	Flow @ 50 Cycles/Minute	Max Hydraulic Temp Limit
650940-XXD-B	50 - 2,000 (3.4 - 137.9)	40 - 1,600 (4.1 - 110.3)	50	59.6 (976.6)	3.9 (1.0)	12.9 (48.8)	130° F (54° C)

Accessories

Part Number	Description
650940-XXD-B	
61938-1	Wall mount bracket
66999-B	Wet Sol
65138	Floor mount
67136	Floor mount adapter
637211-XX3	Lower pump repair kit

Reference mounting footprint "A" for related rams and accessories.

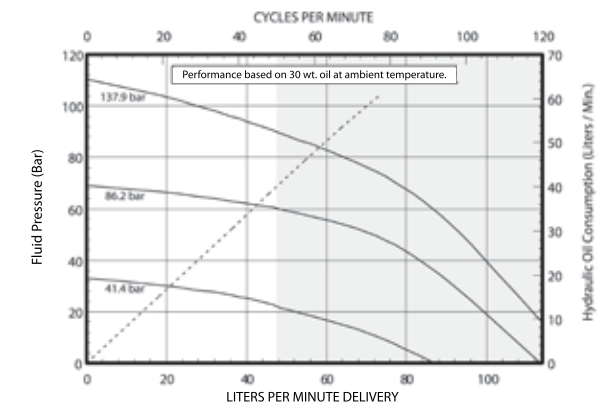
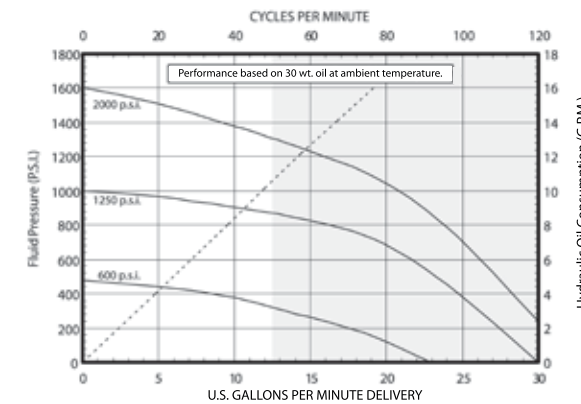

1.2:1 Ratio, 4.125" ², Chop-Check

6 5 0 9 4 1 - X X E - C

Packings/Springs

F4 – UHMW-PE/Leather staggered (upper), UHMW-PE (lower)

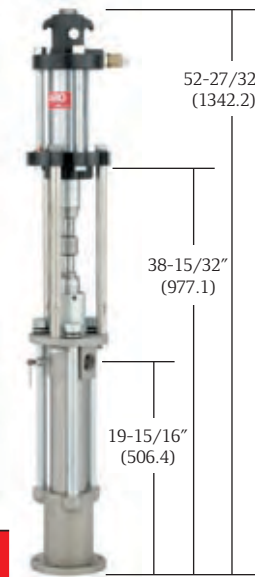

650941-XXE-C

Model	Lower Pump Material	Plunger Material	Hydraulic Motor	Stroke in (mm)	Hydraulic Inlet	Hydraulic Return	Lower Pump Model	Material Inlet	Material Outlet	Weight lb (kg)
650941-XXE-C	Carbon steel*	Carbon steel**	67314	6" (152)	1/2" NPT(F)	3/4" NPT(F)	66236-XXE-B	Bolted flange	1-1/2" NPT(F)	144 (65.3)

*Nickel-plated.

**Hard chrome-plated.

2:1 Ratio, 2.062" ², Chop-Check

6 5 0 9 3 4 - X 4 3 - C

Packing

G – UHMW-PE/Leather staggered

Spring

4 – Multiple-wave spring



650934-X43-C

Model	Lower Pump Material	Plunger Material	Hydraulic Motor	Stroke in (mm)	Hydraulic Inlet	Hydraulic Return	Lower Pump Model	Material Inlet	Material Outlet	Weight lb (kg)
650934-X43-C	Carbon steel*	17-4 stainless steel**	67147	6" (152)	3/8" NPT(F)	1/2" NPT(F)	66243-XX3-B	Bolted Flange	1" NPT(F)	62.4 (28.3)

*Nickel-plated.

**Hard chrome-plated.

Accessories

Model	Hydraulic Inlet Pressure Range psi (bar)	Fluid Pressure Range psi (bar)	Max Cycles/Minute	Displacement per Cycle cu in (cm ³)	Cycles per gal (L)	Flow @ 50 Cycles/Minute	Max Hydraulic Temp Limit
650941-XXE-C	50 – 2,000 (3.4 – 137.9)	60 – 2,670 (4.1 – 184.1)	50	40.2 (658.7)	5.7 (1.5)	8.7 (33.1)	130° F (54° C)

Part Number	Description
650941-XXE-C	Wet Sol
66333-B	Wet Sol
65139	Floor mount
637128-XX4-B	Lower pump repair kit

Reference mounting footprint "B" for related rams and accessories.

Accessories

Model	Hydraulic Inlet Pressure Range psi (bar)	Fluid Pressure Range psi (bar)	Max Cycles/Minute	Displacement per Cycle cu in (cm ³)	Cycles per gal (L)	Flow @ 50 Cycles/Minute	Max Hydraulic Temp Limit
650934-X43-C	50 – 1,200 (3.4 – 82.8)	100 – 2,400 (6.9 – 165.5)	50	12.5 (204.8)	18.5 (4.8)	2.7 (10.2)	130° F (54° C)

Part Number	Description
650934-X43-C	Wet Sol
66999-B	Wet Sol
65138	Floor mount
67136	Floor mount adapter
637071-XX3-B	Lower pump repair kit

Reference mounting footprint "A" for related rams and accessories.

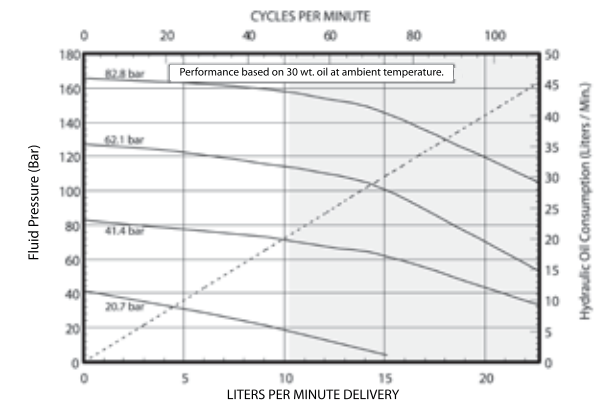
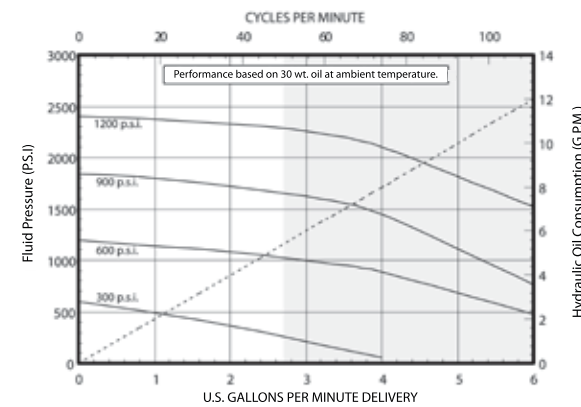
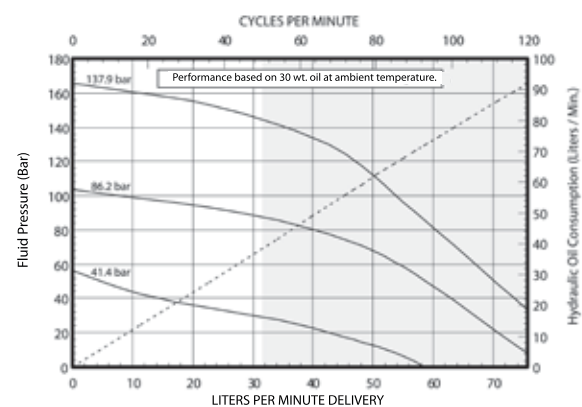
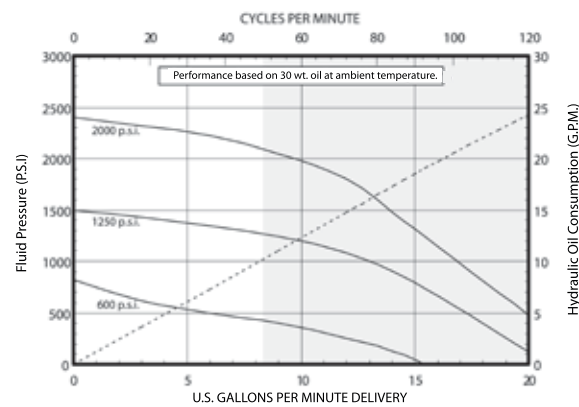

3.3:1 Ratio, 2.062" ², 2-Ball

6 5 0 9 4 4 - C 4 3 - B

Packing
C – UHMW-PE
Spring
4 – Multiple wave spring

Plunger
3 – Hardened stainless steel with hard chrome plating

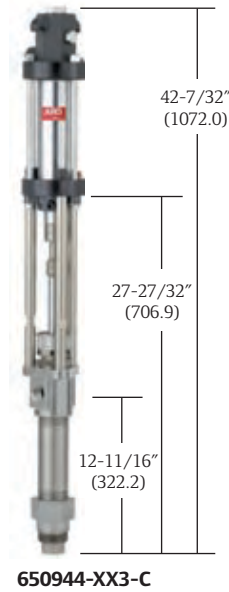

650944-XX3-C

Model	Lower Pump Material	Plunger Material	Hydraulic Motor	Stroke in (mm)	Hydraulic Inlet	Hydraulic Return	Lower Pump Model	Material Inlet	Material Outlet	Weight lb (kg)
650944-C43-B	316 stainless steel*	17-4 stainless steel*	3/8" NPT(F)	6" (152)	33/8" – 18" NPT(F)	1/2" NPT(F)	66301-XXX	1-1/2" NPT(F), 2" NPT(F)	1" NPT(F)	41.3 (18.7)

*Hard chrome-plated.

3.6:1 Ratio, 2.062" ², Chop-Check

6 5 0 9 3 5 - C 4 3 - C

Packing
C – UHMW-PE

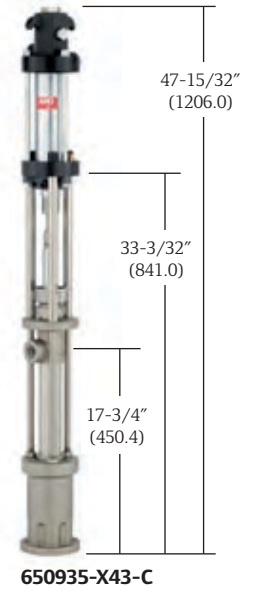

650935-X43-C

Model	Lower Pump Material	Plunger Material	Hydraulic Motor	Stroke in (mm)	Hydraulic Inlet	Hydraulic Return	Lower Pump Model	Material Inlet	Material Outlet	Weight lb (kg)
650935-C43-C	Carbon steel*	17-4 stainless steel**	67147	6" (152)	3/8" NPT(F)	1/2" NPT(F)	66266-X43-B	Bolted flange	1" NPT(F)	62.1 (28.2)

*Nickel-plated.

**Hard chrome-plated.

Accessories

Model	Hydraulic Inlet Pressure Range psi (bar)	Fluid Pressure Range psi (bar)	Max Cycles/Minute	Displacement per Cycle cu in (cm ³)	Cycles per gal (L)	Flow @ 50 Cycles/Minute	Max Hydraulic Temp Limit
650944-C43-B	50 – 1,200 (3.4 – 82.8)	165 – 3,994 (11.4 – 275.4)	50	7.4 (121.2)	31.1 (8.2)	1.6 (6.1)	130° F (54° C)

Part Number	Description
650944-C43-B	
61938-1	Wall mount bracket
66999-B	Wet Sol
65138	Floor mount
67136	Floor mount adapter
637306-X43	Lower pump repair kit

Reference mounting footprint "A" or "D" for related rams and accessories.

Accessories

Part Number	Description
650935-C43-C	
66333-B	Wet Sol
65138	Floor mount
637074-X43-B	Lower pump repair kit

Reference mounting footprint "A" for related rams and accessories.

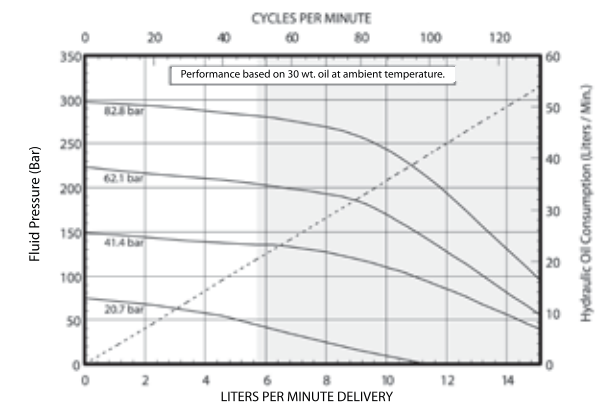
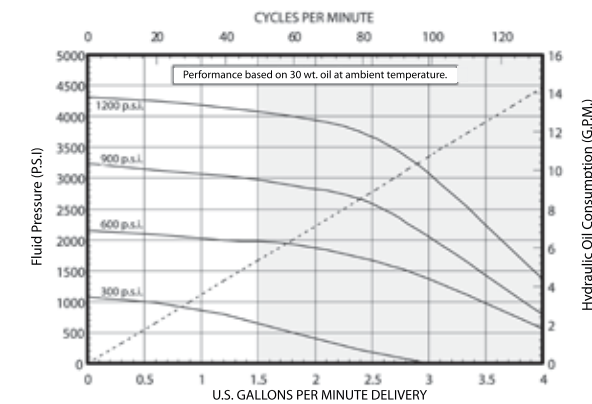
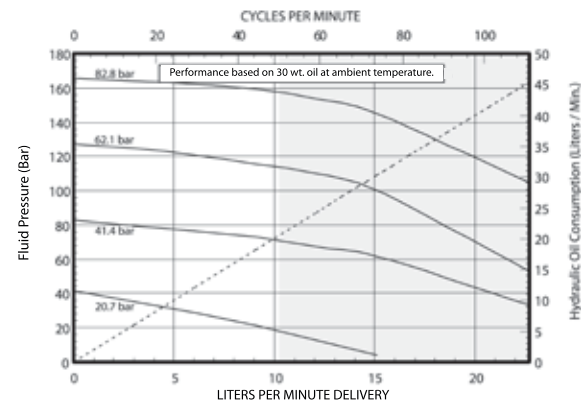
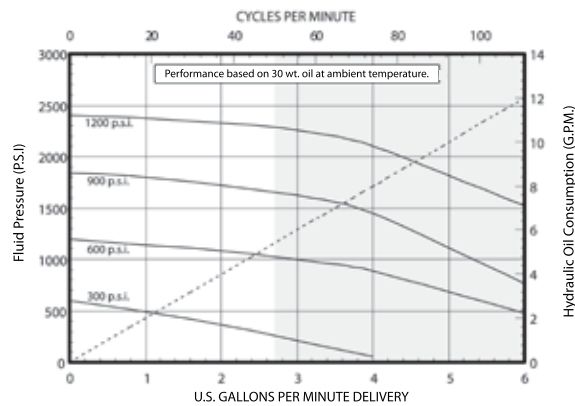

Model Number Index

MODEL	PAGE	MODEL	PAGE	MODEL	PAGE	MODEL	PAGE	MODEL	PAGE
100067	46	650239	11	651614-X	34	67121-P43	116	NP322R02-1	14
100083	46	650239-1	11	651615-D	34	67124-P43	115	NP322R03-1	17
100085	65	650240	11	651616-X	35	67125-P43	116	NP322R03-2	17
100090	46	65030-X-B	50	651728	63	67133	37	NP328C01-2	24
102-X	69	650408-B	78	651729	63	67134	40, 42	NP328C02-2	24
110-907	70	650408-X-B	78	651730	63	67136	40, 42	NP328D01-1	25
116218-X	65	650409	79	651747-X-B	48	67139	60	NP328D01-2	25
119378-X	65	650409-X	79	651780-AXA-B	43	67140-X	58	NP328D01-3	26
104104-NOX	65	650439-X4B	99	651780-AXB-B	43	67187-1	60	NP328D01-4	26
104104-NS2	65	650453-X	80	651780-BXA-B	43	67195-1	41	NP328D01-6	26
104174-X	65	650483-X4X	83	651780-BXB-B	43	67195-2	41	NP328D02-1	27
104253-2	65	650484-X4X	87	651780-BXR-B	43	67195-3	41	NP328D02-2	27
105B03XX	70	650485-X4X	92	651780-CXB-B	43	67195-5	41	NP409L01-1	23
23644-400	60	650491-X43-B	106	651780-CXC-B	43	67195-6	41, 42	NP409L01-2	23
27520-X	45	650492-X43-B	111	651780-CXR-B	43	67195-7	42	NP421R-52-C43	20
28353	62	650540-1	12	651781-BXB-B	45	67196-1	42	NP422R-02-G43	20
29882	46	650541-1	12	651781-BXD-B	45	67196-2	42	NP422R-53-R43	20
29883	46	650542-1	15	651781-BXE-B	45	67196-3	42	NP424R-02-P43	20
29975	46	650542-2	15	651781-CXB-B	45	67196-5	42	NP424R-52-343	20
300-301	71	650543-1	15	651781-CXD-B	45	67196-6	42	NP424R-52-R43	20
300-911X	69	650554	29	651790-AXB-B	44	67196-7	42	NP424R-53-R43	20
300-963	71	650556	29	651790-AXC-B	44	67282-1	16	NP431R-02-C43	20
350-58X	71	650556-1	30	651790-AXD-B	44	67282-2	16	NP431R-02-G43	20
350-63X	71	650639-X4B	101	651790-BXC-B	44	67283-1	17	NP431R-02-P43	20
360-6XX	70	650640-X4B	100	651790-BXD-B	44	67283-2	17	NP431R-02-R43	20
361-936	71	650683-X4X	88	651790-BXE-B	44	67327	37	NP434R-02-343	20
361TX1FOX	70	650684-X4X	94	651790-BXR-B	44	67342-1	39	NP434R-02-C43	20
362-005	71	650685-X4X	96	651830	59	67342-2	39	NP434R-02-G43	20
362-853X	71	650691-X43-B	112	651840-1	39	67342-3	39	NP434R-02-P43	20
364-224	71	650692-X43-B	119	651840-2	39	67345-1	39	NP434R-02-R43	20
364-538	70	6507075-1-B	33	651840-3	39	67346-1	39	NP434R-52-P43	20
364-6XX	70	650839-X4G-B	103	651841-1	39	67347-1	39	NP443EP43R4-12	18
400-667	70	650840-X4G-B	102	651842-1	39	67347-11	39	NP621R-02-G43	21
400-72X	69	650863-X4D-B	95	651851	56	67347-12	39	NP621R-52-R43	21
400-72X	71	650866-XXD-B	82	651852	56	73121	57	NP622R-02-G43	21
403-114-X	70	650867-XXD-B	84	651853	56	73122	57	NP622R-53-R43	21
403-800-115	71	650871-XXE-C	107	65940	63	76751	47	NP624R-02-C43	21
407441-X	53	650875-XXE-C	108	65986-1	58	76763	58	NP624R-02-G43	21
407442-X	53	650883-X4X-B	93	66073-1	75	90552	40, 42	NP624R-02-P43	21
407442-X-4	53	650888-XXD	113	66100	58	91020-X	59	NP624R-02-R43	21
407443-X	53	650889-XXD	117	66101	58	91192-X	54	NP624R-52-R43	21
407444-X	53	650891-XXD-C	118	66197	56	91363-10	42	NP631R-02-343	21
60307-1	57	650919	30	66248	41	91364-10	40	NP631R-02-C43	21
61113	58	650934-X43-C	127	66248-1	41	91790	61	NP631R-02-G43	21
612041-X	73	650935-C43-C	129	66258	48	92339	40, 42	NP631R-02-P43	21
612042-1	73	650940-XXD-B	125	66333-B	61	92460	61	NP631R-02-R43	21
613112-XXF-C	81	650941-XXE-C	126	66334-B	61	92968	46	NP631R-13-P43	21
613123-XXF-C	85	650943-X4X-B	124	66335-X	37	92969	46	NP631R-52-343	21
613124-XXF-C	90	650944-C43-B	128	66469	39	93504-1	46	NP631R-52-G43	21
61879	73, 74	650949-X4B	123	66480	59	93505-1	46	NP631R-52-R43	21
621501-X	67	650950-X4B	122	66504	50	93506-1	46	NP634R-02-C43	21
622201-X	67	650963-X4D-B	97	66516	41	93944-X	54	NP634R-02-G43	21
622204-X	67	650967-XXD-B	89	66516-1	41	93945-X	54	NP634R-03-R43	21
622581-6	67	650971-XXE-C	114	66516-2	41	94254	59	NP634R-52-R43	21
622651-1-F	67	650989-XXD	120	66516-5	41	94256	54, 59	NP645R01-1	19
622681-6	67	65107	46	66516-6	41	94783-1	57	NP645R02-1	19
622701-6	58	65109	59	66516-7	41	94806	45, 46	NP828C01-1	28
622702-X	58	651100	57	66517	41	C28121-600	73	NP834R-01-G4D	22
62274	62	651103	57	66517-1	41	C28121-800	62	NP834R-01-R4D	22
628042-25	67	651104-X	57	66517-2	41	C28241-810	62	NP834R-02-C4D	22
628081-X	67	65116	34	66517-5	41	CAT66P-X-X	64	NP834R-02-G4D	22
628084-X	67	65138	55	66517-6	41	CHW-X	65	NP834R-02-R4D	22
628088-7	55	65139	55	66517-7	41	CSN-X	65	NP834R-52-R4D	22
628089-X	55	651412	54	66541-XX	47	H253SS-X-X	64	NP836R-05-F4E	22
635040	60	651412-8	54	66542	58	H254SS-X-X	64	NPB44R01-1	18
635043	60	651418-X-B	54	66554-2	60	IS431-A1	37	P29241-610	62
635106	51	651420-X	54	66568	59	MQ3728-X-X	64	P29122-600	62
635107	51	651421-X	54	66713	34	MQ3729-X-X	64	TB022B-X-X	64
635108	51	651422-X	54	66717	59	NM2202A-X1-X31	75	TB03EB-X-X	64
635117	51	651500	47	66718	61	NM2202B-X1-X31	75	TB035B-X-X	64
636075	51	651500-1	49	66731	39	NM2304A-X1-X11	76	TB04EB-X-X	64
636077	51	651511	47	66731-1	39	NM2304B-X1-X1X	76	TB045B-X-X	64
636083	51	651511-1	49	66731-2	39	66732	39	TB06EB-X-X	64
636084	51	651512-X	54	66732-1	39	66732-2	39	TB066B-X-X	64
636085	51	651513-11-B	47	66971	56	67073	55	TCXXXX-D	50
636086-B	51	651513-12-B	49	67075	33	67075-B	33		
636087-B	51	651533	47, 49	67075-1-B	33	67088-4	75		
636088	51	651536-1	47	67088-4	75	67120-P43	115		
640067	33	651537-1	47						
640169	33	651551	50						
641523-1	47	651555-B	50						
650110-X	74	651612-X	36						

Warranty and Emissions

General Piston Pump Warranty

Ingersoll Rand / ARO Piston Pumps warrants to the original use purchaser of the Ingersoll Rand / ARO Piston Pumps-manufactured products depicted in this catalog that Ingersoll Rand / ARO Piston Pumps will repair or replace free of charge, including return shipping costs within the continental United States of America, any such product which under normal use and service proves defective in material or workmanship, as determined by ARO Inspection, within five (5) years from the date of purchase, provided the claimed defective product or thereof is promptly returned to the Ingersoll Rand / ARO Piston Pumps factory or Customer Service Center with transportation charges prepaid.

If Ingersoll Rand / ARO Piston Pumps inspection discloses no defect in material or workmanship, repair or replacement and return will be made at customary charges.

The foregoing warranty supersedes, voids, and is in lieu of all or any other warranties, express or implied, and no warranty of merchantability or fitness for particular purpose is intended or made. The sole obligation of Ingersoll Rand / ARO Piston Pumps and the original-use purchaser's sole remedy is as stated above, and in no event shall Ingersoll Rand / ARO Piston Pumps be liable for any special, direct, indirect, incidental, consequential, or other damages or expenses of any nature including, without limitation, loss of profits or production time incurred by the original-use purchaser or any other party.

Air Systems Components Warranty

Ingersoll Rand / ARO Piston Pumps warrant to the original-use purchaser of the air systems components depicted in this catalog that Ingersoll Rand / ARO Piston Pumps will repair or replace, free of charge, including return shipping costs within the continental United States of America, any such product which under normal use and service proves defective in material or workmanship, as determined by ARO Inspection, within twelve (12) months from the date of purchase provided the claimed defective product or thereof is promptly returned to the Ingersoll Rand / ARO Piston Pumps Customer Service Repair Center or a factory-authorized service repair center, with transportation charges prepaid. Full warranty information is available upon request.

Noise Emissions

Pump sound pressure levels published here have been updated to an Equivalent Continuous Sound Level (LAeq) to meet the intent of ANSI S1.13-1971. CAGI-PNEUROP S5.1 using four (4) microphone locations.

Pump Motor Size/Stroke (in)	Muffler	Air Operating Pressure psi	Cycles/Minute	Sound Pressure (LAeq)
PISTON PUMPS				
2" / 3"	None	150 psi	120	80.0 db(A)
2" / 6"	None	150 psi	75	77.8 db(A)
3" / 3"	None	150 psi	120	85.0 db(A)
4 1/4" / 4"	91790	150 psi	60	80.0 db(A)
4 1/4" / 6"	91790	150 psi	60	81.8 db(A)
6" / 6"	91790	100 psi – 150 psi	60	80.0 db(A) to 81.8 db(A)
8" / 6"	92460	120 psi	60 – 70	88.0 db(A) to 89.8 db(A)
10" / 6"	66718	90 psi	70	84.8 db(A)
12" / 6"	66718	90 psi	70	89.8 db(A)

Distributed by:



Ingersoll Rand Industrial Technologies provides products, services, and solutions to enhance the efficiency and productivity of our commercial, industrial, and process customers. Our innovative products include air compressors, air systems components, tools, pumps, material and fluid handling systems, and microturbines.

(800) 495-0276 • fluids.ingersollrand.com